

HOBBYWING® XR10Pro G3/G3X SETUP SHEET

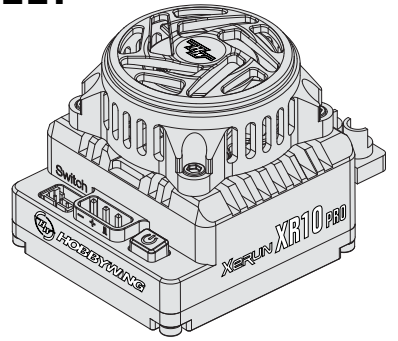

Driver: _____
 Date: 2024/12/30
 Track: つくばRC パーク
 Event: テスト
 Temperature - Air: _____ Track: _____
 Traction: Low Medium High
 Composition: Asphalt AstroTurf Carpet Dirt Grass _____

Vehicle: _____
 Firmware: _____
 Motor: G4R 17.5T
 Endbell Timing: 47
 Rotor: 7-12.2スチール 30820416
 Layout: Tight Mixed Open

Data Record	Max ESC Temperature: _____	Notes 17.5Tブースト 参考セッティングシート ESC:G3X ギヤ比:7.37 バッテリー:SUNPADOW ERC Plus 5300mAh 送受信機:SANWA
	Max Motor Temperature: _____	
	Min Battery Voltage: _____	
	Max Motor RPM: _____	

Type	Item	Programmable Items	Parameter Values															
			Basic			Advanced												
General Setting	1A	Settings Mode	Basic			Advanced												
	1B	Running Mode	Forward with Brake			Forward/Rev with Brake			Forward & Rev									
	1C	Max. Reverse Force	20%			50%			75%				100%					
	1D	Cutoff Voltage	Disabled			Auto (3.5V/Cell)			3.0-7.4V Adjustable (Step: 0.1V)									
	1E	ESC Thermal Protection	Disabled			105°C/221°F			125°C/257°F									
	1F	Motor Thermal Protection	Disabled			105°C/221°F			125°C/257°F									
	1G	BEC Voltage	6.0			5.0V-7.4V Adjustable (Step:0.1V)												
	1H	Smart Fan	Disabled			Enabled												
	1I	Auto Off	Disabled			Remote Off			Delay 5 Minutes		Delay 10 Minutes							
	1J	Sensor Mode	Full Sensored			Sensored/Sensorless Hybrid												
	1K	Motor Rotation	CCW			CW												
	1L	Phase-AC Swap	Disabled			Enabled												
Throttle Control	2A	Throttle Rate Control	30 1-30 Adjustable (Step: 1)															
	2B	Throttle Curvature	2 -10~10 (Step: 1)							Customized: _____								
	2C	Neutral Range	6 3%-10% Adjustable (Step: 1%)															
	2D	Initial Throttle Force	8 1-15 Adjustable (Step: 1)															
	2E	Coast	0 0-15% Adjustable (Step: 1%)															
	2F	PWM Drive Frequency	4 2K-32K (Step: 1)							Customized: _____								
	2G	Softening Value	0 0-30° Adjustable (Step: 1°)															
	2H	Softening Range	<input checked="" type="checkbox"/>	10%	20%	25%	30%	35%	40%	45%	50%	55%	60%	65%	70%	75%		
	2I	Freewheeling	Disabled			Enabled												
	2J	RPM Decrease Rate	1 1-20 (Step: 1)															
Brake Control	3A	Drag Brake Force	0 0%-100% Adjustable (Step: 1%)															
	3B	Drag Brake Rate	Auto			20 1-20 Adjustable (Step: 1)												
	3C	Drag Brake Frequency	0.5K			2 1K-16K (Step: 1K)												
	3D	Max. Brake Force	100 0%-150% Adjustable (Step: 1%)															
	3E	Brake Rate Control	20 1-20 Adjustable (Step: 1)															
	3F	Brake Control	Linear			Traditional			Disc Brake									
	3G	ABS Force	0 0-20% (Step: 1%)															
	3H	Brake Curvature	0 -10~10 (Step:1)							Customized: _____								
3I	Brake Frequency	0.5K			2 1K-16K (Step: 1K)													
Timing	4A	Boost Timing	50 0-64° Adjustable (Step: 1°)															
	4B	Boost Timing Activation	Auto			PWM			Throttle									
	4C	Boost Start RPM	500 500-35000RPM (Step: 500RPM)															
	4D	Boost End RPM	16500 3000-60000RPM (Step: 500RPM)															
	4E	Boost Start TH	10 1%-90% (Step: 1%)															
	4F	Boost End TH	50 10%-100% (Step: 1%)															
	5A	Turbo Timing	35 0-64° Adjustable (Step: 1°)															
	5B	Turbo Delay	Instant	0.05s	<input checked="" type="checkbox"/> 0.1s	0.15s	0.2s	0.25s	0.3s	0.35s	0.4s	0.45s	0.5s	0.6s	0.7s	0.8s	0.9s	1.0s
	5C	Turbo Increase Rate	Instant	1deg/0.1s	2deg/0.1s	3deg/0.1s	5deg/0.1s	8deg/0.1s	12deg/0.1s	16deg/0.1s	20deg/0.1s	25deg/0.1s	30deg/0.1s	<input checked="" type="checkbox"/>				
	5D	Turbo Decrease Rate	Instant	1deg/0.1s	2deg/0.1s	3deg/0.1s	5deg/0.1s	8deg/0.1s	12deg/0.1s	16deg/0.1s	20deg/0.1s	25deg/0.1s	<input checked="" type="checkbox"/>	30deg/0.1s				
Config.	6A	Motor Poles	2 2-10 (Step: 2)															
	6B	Gear Ratio (FDR)	7.37 2.0-12.0 (Step: 0.1)															
	6C	Tire Diameter	62 30mm-150mm (Step: 1)															