

# HOBBYWING® XR10Pro G3/G3X SETUP SHEET

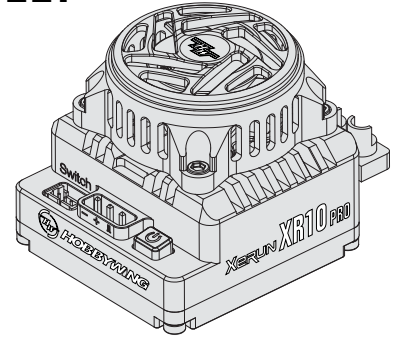

Driver: \_\_\_\_\_ Vehicle: \_\_\_\_\_  
 Date: \_\_\_\_\_ Firmware: \_\_\_\_\_  
 Track: \_\_\_\_\_ Motor: \_\_\_\_\_  
 Event: \_\_\_\_\_ Endbell Timing: \_\_\_\_\_  
 Temperature - Air: \_\_\_\_\_ Track: \_\_\_\_\_ Rotor: \_\_\_\_\_  
 Traction:  Low  Medium  High Layout:  Tight  Mixed  Open  
 Composition:  Asphalt  Astroturf  Carpet  Dirt  Grass  \_\_\_\_\_

<b>Data Record</b>	Max ESC Temperature: _____	Notes
	Max Motor Temperature: _____	
	Min Battery Voltage: _____	
	Max Motor RPM: _____	

Type	Item	Programmable Items	Parameter Values															
			Basic			Advanced												
<b>General Setting</b>	1A	Settings Mode	Basic			Advanced												
	1B	Running Mode	Forward with Brake			Forward/Rev with Brake			Forward & Rev									
	1C	Max. Reverse Force	25%			50%			75%			100%						
	1D	Cutoff Voltage	Disabled			Auto (3.5V/Cell)			3.0-7.4V Adjustable (Step: 0.1V)									
	1E	ESC Thermal Protection	Disabled			105°C/221°F			125°C/257°F									
	1F	Motor Thermal Protection	Disabled			105°C/221°F			125°C/257°F									
	1G	BEC Voltage	5.0V-7.4V Adjustable (Step:0.1V)															
	1H	Smart Fan	Disabled			Enabled												
	1I	Auto Off	Disabled			Remote Off			Delay 5 Minutes		Delay 10 Minutes							
	1J	Sensor Mode	Full Sensored			Sensored/Sensorless Hybrid												
	1K	Motor Rotation	CCW			CW												
	1L	Phase-AC Swap	Disabled			Enabled												
<b>Throttle Control</b>	2A	Throttle Rate Control	1-30 Adjustable (Step: 1)															
	2B	Throttle Curvature	-10~10 (Step: 1)						Customized: _____									
	2C	Neutral Range	3%-10% Adjustable (Step: 1%)															
	2D	Initial Throttle Force	1-15 Adjustable (Step: 1)															
	2E	Coast	0-15% Adjustable (Step: 1%)															
	2F	PWM Drive Frequency	2K-32K (Step: 1)						Customized: _____									
	2G	Softening Value	0-30° Adjustable (Step: 1°)															
	2H	Softening Range	0%	10%	20%	25%	30%	35%	40%	45%	50%	55%	60%	65%	70%	75%		
	2I	Freewheeling	Disabled			Enabled												
	2J	RPM Decrease Rate	1-20 (Step: 1)															
<b>Brake Control</b>	3A	Drag Brake Force	0%-100% Adjustable (Step: 1%)															
	3B	Drag Brake Rate	Auto			1-20 Adjustable (Step: 1)												
	3C	Drag Brake Frequency	0.5K			1K-16K (Step: 1K)												
	3D	Max. Brake Force	0%-150% Adjustable (Step: 1%)															
	3E	Brake Rate Control	1-20 Adjustable (Step: 1)															
	3F	Brake Control	Linear			Traditional			Disc Brake									
	3G	ABS Force	0-20% (Step: 1%)															
	3H	Brake Curvature	-10~10 (Step:1)						Customized: _____									
	3I	Brake Frequency	0.5K			1K-16K (Step: 1K)												
<b>Timing</b>	4A	Boost Timing	0-64° Adjustable (Step: 1°)															
	4B	Boost Timing Activation	Auto			RPM			Throttle									
	4C	Boost Start RPM	500-35000RPM (Step: 500RPM)															
	4D	Boost End RPM	3000-60000RPM (Step: 500RPM)															
	4E	Boost Start TH	1%-90% (Step: 1%)															
	4F	Boost End TH	10%-100% (Step: 1%)															
	5A	Turbo Timing	0-64° Adjustable (Step: 1°)															
	5B	Turbo Delay	Instant	0.05s	0.1s	0.15s	0.2s	0.25s	0.3s	0.35s	0.4s	0.45s	0.5s	0.6s	0.7s	0.8s	0.9s	1.0s
	5C	Turbo Increase Rate	Instant	1deg/0.1s	2deg/0.1s	3deg/0.1s	5deg/0.1s	8deg/0.1s	12deg/0.1s	16deg/0.1s	20deg/0.1s	25deg/0.1s	30deg/0.1s					
	5D	Turbo Decrease Rate	Instant	1deg/0.1s	2deg/0.1s	3deg/0.1s	5deg/0.1s	8deg/0.1s	12deg/0.1s	16deg/0.1s	20deg/0.1s	25deg/0.1s	30deg/0.1s					
<b>Config.</b>	6A	Motor Poles	2-10 (Step: 2)															
	6B	Gear Ratio (FDR)	2.0-12.0 (Step: 0.1)															
	6C	Tire Diameter	30mm-150mm (Step: 1)															