

# HOBBYWING® XR10Pro G3/G3X SETUP SHEET

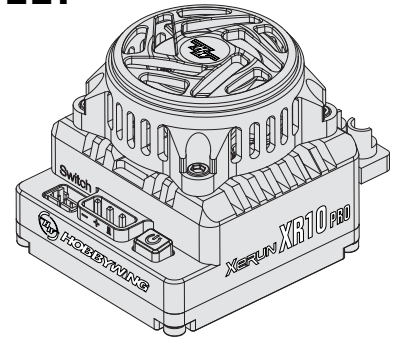

Driver: \_\_\_\_\_ Vehicle: \_\_\_\_\_  
 Date: \_\_\_\_\_ Firmware: \_\_\_\_\_  
 Track: \_\_\_\_\_ Motor: \_\_\_\_\_  
 Event: \_\_\_\_\_ Endbell Timing: \_\_\_\_\_  
 Temperature - Air: \_\_\_\_\_ Track: \_\_\_\_\_ Rotor: \_\_\_\_\_  
 Traction:  Low  Medium  High Layout:  Tight  Mixed  Open  
 Composition:  Asphalt  Astroturf  Carpet  Dirt  Grass  \_\_\_\_\_

|                    |                              |       |
|--------------------|------------------------------|-------|
| <b>Data Record</b> | Max ESC Temperature: _____   | Notes |
|                    | Max Motor Temperature: _____ |       |
|                    | Min Battery Voltage: _____   |       |
|                    | Max Motor RPM: _____         |       |

| Type                    | Item | Programmable Items       | Parameter Values                 |           |           |           |                            |           |            |            |                                  |            |            |      |                  |      |      |      |
|-------------------------|------|--------------------------|----------------------------------|-----------|-----------|-----------|----------------------------|-----------|------------|------------|----------------------------------|------------|------------|------|------------------|------|------|------|
|                         |      |                          | Basic                            |           |           |           | Advanced                   |           |            |            |                                  |            |            |      |                  |      |      |      |
| <b>General Setting</b>  | 1A   | Settings Mode            | Basic                            |           |           |           | Advanced                   |           |            |            |                                  |            |            |      |                  |      |      |      |
|                         | 1B   | Running Mode             | Forward with Brake               |           |           |           | Forward/Rev with Brake     |           |            |            | Forward & Rev                    |            |            |      |                  |      |      |      |
|                         | 1C   | Max. Reverse Force       | 25%                              |           |           |           | 50%                        |           |            |            | 75%                              |            |            |      | 100%             |      |      |      |
|                         | 1D   | Cutoff Voltage           | Disabled                         |           |           |           | Auto (3.5V/Cell)           |           |            |            | 3.0-7.4V Adjustable (Step: 0.1V) |            |            |      |                  |      |      |      |
|                         | 1E   | ESC Thermal Protection   | Disabled                         |           |           |           | 105°C/221°F                |           |            |            | 125°C/257°F                      |            |            |      |                  |      |      |      |
|                         | 1F   | Motor Thermal Protection | Disabled                         |           |           |           | 105°C/221°F                |           |            |            | 125°C/257°F                      |            |            |      |                  |      |      |      |
|                         | 1G   | BEC Voltage              | 5.0V-7.4V Adjustable (Step:0.1V) |           |           |           |                            |           |            |            |                                  |            |            |      |                  |      |      |      |
|                         | 1H   | Smart Fan                | Disabled                         |           |           |           | Enabled                    |           |            |            |                                  |            |            |      |                  |      |      |      |
|                         | 1I   | Auto Off                 | Disabled                         |           |           |           | Remote Off                 |           |            |            | Delay 5 Minutes                  |            |            |      | Delay 10 Minutes |      |      |      |
|                         | 1J   | Sensor Mode              | Full Sensored                    |           |           |           | Sensored/Sensorless Hybrid |           |            |            |                                  |            |            |      |                  |      |      |      |
|                         | 1K   | Motor Rotation           | CCW                              |           |           |           | CW                         |           |            |            |                                  |            |            |      |                  |      |      |      |
|                         | 1L   | Phase-AC Swap            | Disabled                         |           |           |           | Enabled                    |           |            |            |                                  |            |            |      |                  |      |      |      |
| <b>Throttle Control</b> | 2A   | Throttle Rate Control    | 1-30 Adjustable (Step: 1)        |           |           |           |                            |           |            |            |                                  |            |            |      |                  |      |      |      |
|                         | 2B   | Throttle Curvature       | -10~10 (Step: 1)                 |           |           |           | Customized: _____          |           |            |            |                                  |            |            |      |                  |      |      |      |
|                         | 2C   | Neutral Range            | 3%-10% Adjustable (Step: 1%)     |           |           |           |                            |           |            |            |                                  |            |            |      |                  |      |      |      |
|                         | 2D   | Initial Throttle Force   | 1-15 Adjustable (Step: 1)        |           |           |           |                            |           |            |            |                                  |            |            |      |                  |      |      |      |
|                         | 2E   | Coast                    | 0-15% Adjustable (Step: 1%)      |           |           |           |                            |           |            |            |                                  |            |            |      |                  |      |      |      |
|                         | 2F   | PWM Drive Frequency      | 2K-32K (Step: 1)                 |           |           |           | Customized: _____          |           |            |            |                                  |            |            |      |                  |      |      |      |
|                         | 2G   | Softening Value          | 0-30° Adjustable (Step: 1°)      |           |           |           |                            |           |            |            |                                  |            |            |      |                  |      |      |      |
|                         | 2H   | Softening Range          | 0%                               | 10%       | 20%       | 25%       | 30%                        | 35%       | 40%        | 45%        | 50%                              | 55%        | 60%        | 65%  | 70%              | 75%  |      |      |
|                         | 2I   | Freewheeling             | Disabled                         |           |           |           | Enabled                    |           |            |            |                                  |            |            |      |                  |      |      |      |
|                         | 2J   | RPM Decrease Rate        | 1-20 (Step: 1)                   |           |           |           |                            |           |            |            |                                  |            |            |      |                  |      |      |      |
| <b>Brake Control</b>    | 3A   | Drag Brake Force         | 0%-100% Adjustable (Step: 1%)    |           |           |           |                            |           |            |            |                                  |            |            |      |                  |      |      |      |
|                         | 3B   | Drag Brake Rate          | Auto                             |           |           |           | 1-20 Adjustable (Step: 1)  |           |            |            |                                  |            |            |      |                  |      |      |      |
|                         | 3C   | Drag Brake Frequency     | 0.5K                             |           |           |           | 1K-16K (Step: 1K)          |           |            |            |                                  |            |            |      |                  |      |      |      |
|                         | 3D   | Max. Brake Force         | 0%-150% Adjustable (Step: 1%)    |           |           |           |                            |           |            |            |                                  |            |            |      |                  |      |      |      |
|                         | 3E   | Brake Rate Control       | 1-20 Adjustable (Step: 1)        |           |           |           |                            |           |            |            |                                  |            |            |      |                  |      |      |      |
|                         | 3F   | Brake Control            | Linear                           |           |           |           | Traditional                |           |            |            | Disc Brake                       |            |            |      |                  |      |      |      |
|                         | 3G   | ABS Force                | 0-20% (Step: 1%)                 |           |           |           |                            |           |            |            |                                  |            |            |      |                  |      |      |      |
|                         | 3H   | Brake Curvature          | -10~10 (Step:1)                  |           |           |           | Customized: _____          |           |            |            |                                  |            |            |      |                  |      |      |      |
|                         | 3I   | Brake Frequency          | 0.5K                             |           |           |           | 1K-16K (Step: 1K)          |           |            |            |                                  |            |            |      |                  |      |      |      |
| <b>Timing</b>           | 4A   | Boost Timing             | 0-64° Adjustable (Step: 1°)      |           |           |           |                            |           |            |            |                                  |            |            |      |                  |      |      |      |
|                         | 4B   | Boost Timing Activation  | Auto                             |           |           |           | RPM                        |           |            |            | Throttle                         |            |            |      |                  |      |      |      |
|                         | 4C   | Boost Start RPM          | 500-35000RPM (Step: 500RPM)      |           |           |           |                            |           |            |            |                                  |            |            |      |                  |      |      |      |
|                         | 4D   | Boost End RPM            | 3000-60000RPM (Step: 500RPM)     |           |           |           |                            |           |            |            |                                  |            |            |      |                  |      |      |      |
|                         | 4E   | Boost Start TH           | 1%-90% (Step: 1%)                |           |           |           |                            |           |            |            |                                  |            |            |      |                  |      |      |      |
|                         | 4F   | Boost End TH             | 10%-100% (Step: 1%)              |           |           |           |                            |           |            |            |                                  |            |            |      |                  |      |      |      |
|                         | 5A   | Turbo Timing             | 0-64° Adjustable (Step: 1°)      |           |           |           |                            |           |            |            |                                  |            |            |      |                  |      |      |      |
|                         | 5B   | Turbo Delay              | Instant                          | 0.05s     | 0.1s      | 0.15s     | 0.2s                       | 0.25s     | 0.3s       | 0.35s      | 0.4s                             | 0.45s      | 0.5s       | 0.6s | 0.7s             | 0.8s | 0.9s | 1.0s |
|                         | 5C   | Turbo Increase Rate      | Instant                          | 1deg/0.1s | 2deg/0.1s | 3deg/0.1s | 5deg/0.1s                  | 8deg/0.1s | 12deg/0.1s | 16deg/0.1s | 20deg/0.1s                       | 25deg/0.1s | 30deg/0.1s |      |                  |      |      |      |
|                         | 5D   | Turbo Decrease Rate      | Instant                          | 1deg/0.1s | 2deg/0.1s | 3deg/0.1s | 5deg/0.1s                  | 8deg/0.1s | 12deg/0.1s | 16deg/0.1s | 20deg/0.1s                       | 25deg/0.1s | 30deg/0.1s |      |                  |      |      |      |
| <b>Config.</b>          | 6A   | Motor Poles              | 2-10 (Step: 2)                   |           |           |           |                            |           |            |            |                                  |            |            |      |                  |      |      |      |
|                         | 6B   | Gear Ratio (FDR)         | 2.0-12.0 (Step: 0.1)             |           |           |           |                            |           |            |            |                                  |            |            |      |                  |      |      |      |
|                         | 6C   | Tire Diameter            | 30mm-150mm (Step: 1)             |           |           |           |                            |           |            |            |                                  |            |            |      |                  |      |      |      |