

Name _____

Country _____

Race _____

Track _____

Date _____ Indoor Outdoor Asphalt Carpet

Track Condition Bumpy Flat Technical Mixed Fast

Traction Low Medium High

Air Temp _____ Track Temp _____

Aero

Body _____

Body Position _____

Body Weight _____

Body Rear Height _____

Tires

Front Tire _____ Front Size _____

Rear Tire _____ Rear Size _____

Traction Additive _____

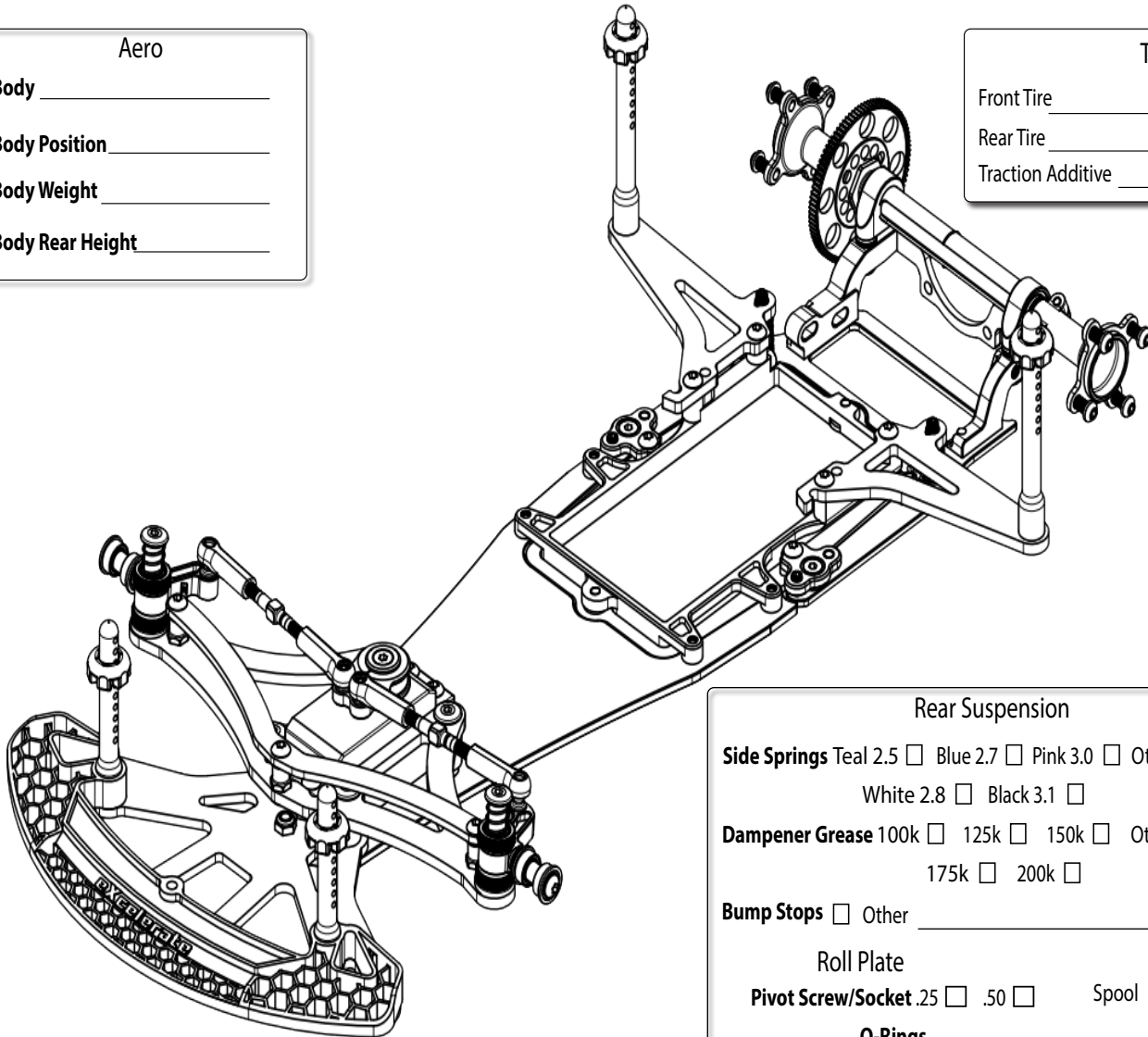

Front Suspension

Camber _____ Kingpin Castor 4 5 6 Other _____

Steering Block -1.5 -3.0 Bump Steer Shims _____ Toe _____

Front Spring Red 4.1 Green 4.6 Orange 5.0 Other _____
White 2.8 Black 3.1

Spring Shim _____ Top Shim _____

Kingpin Shim _____ Front Plate _____ Bottom Shim _____

Dampening Grease _____ Ride Height _____

Front Width _____ Front Droop _____

Rear Suspension

Side Springs Teal 2.5 Blue 2.7 Pink 3.0 Other _____
White 2.8 Black 3.1

Dampener Grease 100k 125k 150k Other _____
175k 200k

Bump Stops Other _____

Roll Plate

Pivot Screw/Socket .25 .50 Spool Gear Diff Ball Diff

O-Rings

Soft Med. Med/Firm Firm

Pivot Plate

Pivot Screw/Socket .25 .50

O-Rings

Soft Med. Med/Firm Firm

Wheel Base Short Long

Rear Axle

Spool Gear Diff Ball Diff

Battery Tray Height _____

Rear Ride Height _____

Rear Droop _____

Rear Width _____

Motor _____

Spur _____

Pinion _____

Battery _____

Battery Plugs Front Back

Battery Plate _____

Notes: _____