

Block diagram of electronics on the board of RC car 1/10

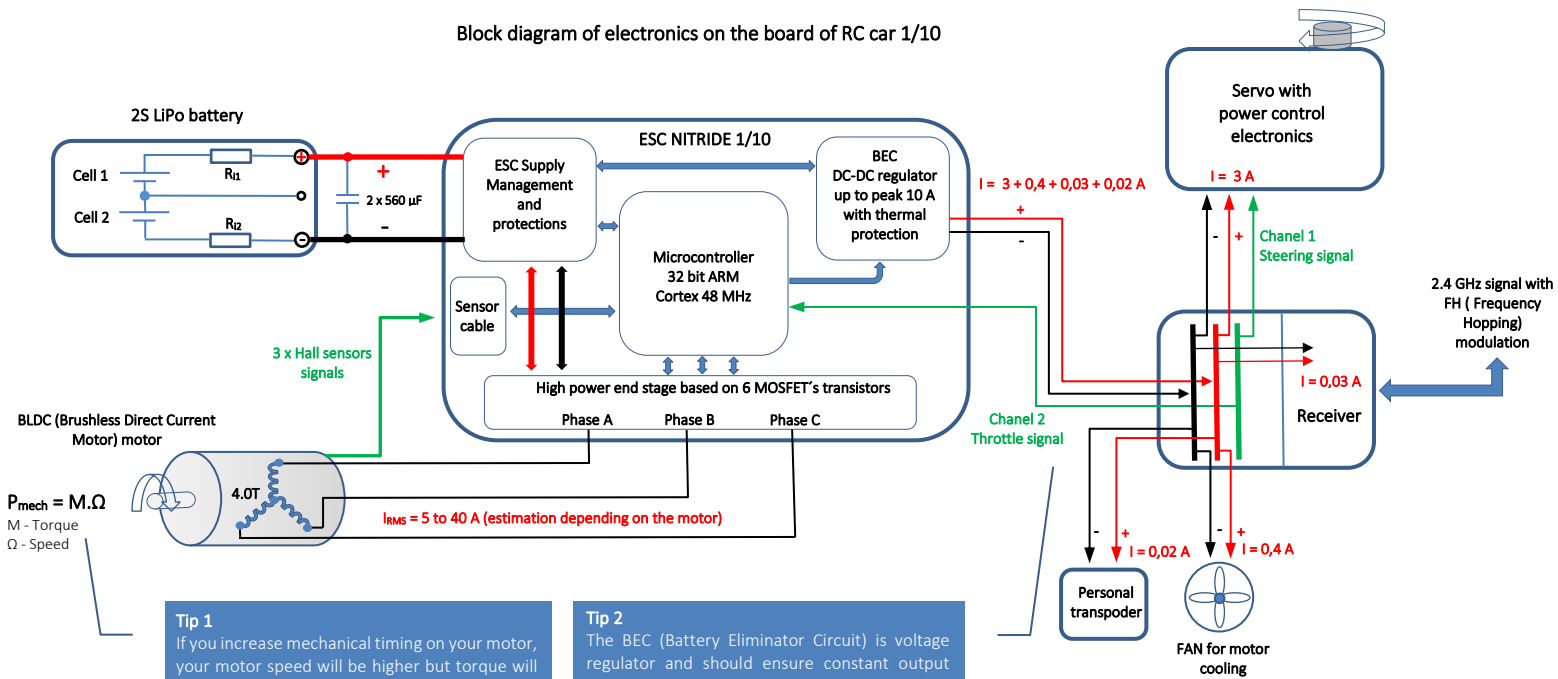

Tip 1

If you increase mechanical timing on your motor, your motor speed will be higher but torque will be less. Simply you can turn speed to torque and opposite. Motor mechanical power is based on the number of turns and motor design.

Tip 2

The BEC (Battery Eliminator Circuit) is voltage regulator and should ensure constant output voltage for electronics in your car except the BLDC motor. Compare the currents consumption for servo, receiver, transponder and FAN at output voltage 7,4 V.