

DATE

DRIVER

CONDITION FLAT BUMPY TIGHT OPEN

CARPET ASPHALT INDOOR OUTDOOR

TRACTION HIGH LOW

TEMP °C AIR TRACK

EVENT TRACK QUALIFYING FINAL

FRONT

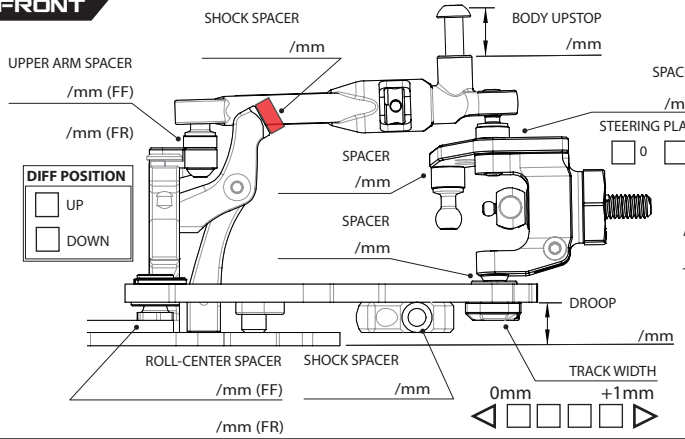

FRONT DIFF

SPOOL

DIFF # /CST

WHEEL HUB

4.0mm 5.0mm

WHEEL SPACER /mm

ACKERMANN SPACER /mm

CENTER PLATE ● (8.5) ● (8.0)

STEERING SPACER /mm

RIDE HEIGHT /mm

CAMBER °

CASTER 4° 5° °

SWAY BAR 1.3 1.4

DOUBLE JOINT DRIVE SHAFT KIT (44.5) LONG (47)

TOE ANGLE °

SHOCK ABSORBER

OIL /CST

LENGTH /mm

REBOUND %

SPRING 2.5 2.6 2.7

ABSORBER MEMBRANCE

PISTON

REAR

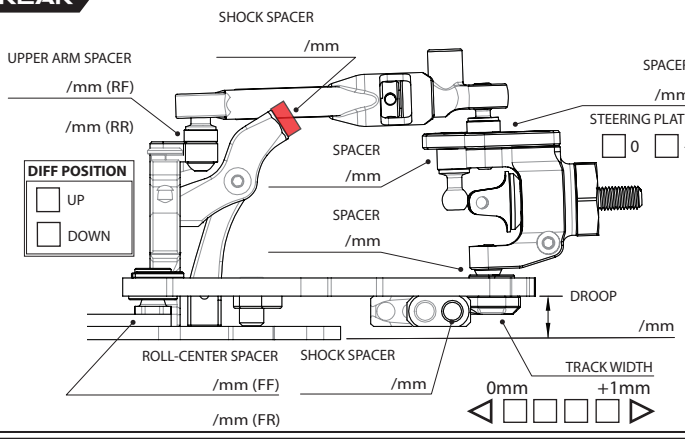

DIFFERENTIAL OIL

/CST

WEIGHT g

WHEEL HUB 4.0mm 5.0mm

WHEEL SPACER /mm

ANTI-ROLL BAR POSITION INNER OUTER

REAR LINK POSITION

RIDE HEIGHT /mm

CAMBER °

CASTER 0° 1° °

SWAY BAR 1.2 1.3

DRIVE SHAFT ALUMINIUM STEEL

TOE ANGLE

SHOCK ABSORBER

OIL /CST

LENGTH /mm

REBOUND %

SPRING 2.5 2.6 2.7

ABSORBER MEMBRANCE

PISTON

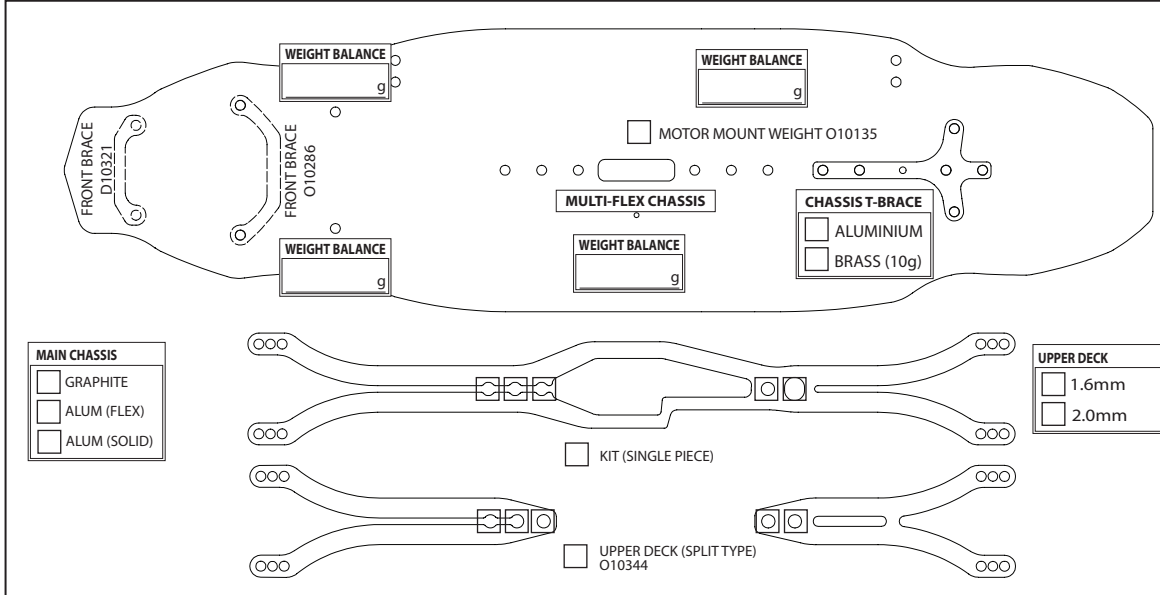

TRACK WIDTH

FRONT /mm

REAR /mm

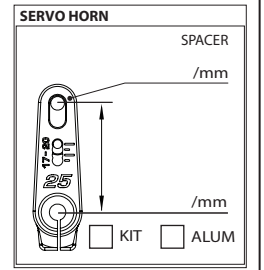
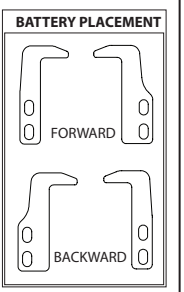

TIRE SETTING

FRONT AND REAR

TIRE

INSERT

WHEEL

ADDITIVE

ADDITIVE TIME Fr /MINS - Rr /MINS

MOTOR **ROTOR** **MOTOR TIMING** °

PINON GEAR **SPUR GEAR** **FINAL RATIO**

ESC **SETUP**

BATTERY SHORT **BODY** **TOTAL WEIGHT** /g

NOTES