



M **M210** **M-CHASSIS**
 RC CAR **M210R** 1/10 EP RC M-Chassis Kit

M **M210**
 RC CAR **M210R**
 INSTRUCTION MANUAL



✉ service@carten-rc.com

4WD **SHAFT DRIVEN**

M-CHASSIS
 1/10 EP RC M-Chassis Kit

WWW.CARTEN-RC.COM

CAUTION

Notice: Thank you for choosing the carten M-CHASSIS M210 M210R. The following items are needed for completion of the KIT, They are not included with this kit (unless noted), and should be obtained from your local hobby shop. **Be sure to read the instructions completely prior to assembly.**

TOOLS NEEDED TO ASSEMBLE

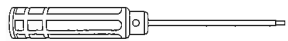

Hex Wrenches(1.5mm / 2.0mm / 2.5mm)

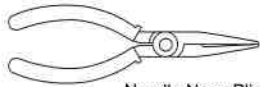

Needle Nose Pliers

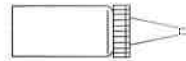

Instant Glue



Box Wrench(5.5mm / 7mm / 10mm)



Scissors



Screw (Sement)

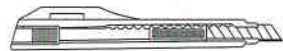

Hobby Knife



Glass or Vinyl Tape

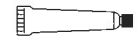

Rubber Glue

ITEMS NEEDED TO CONTROL CAR

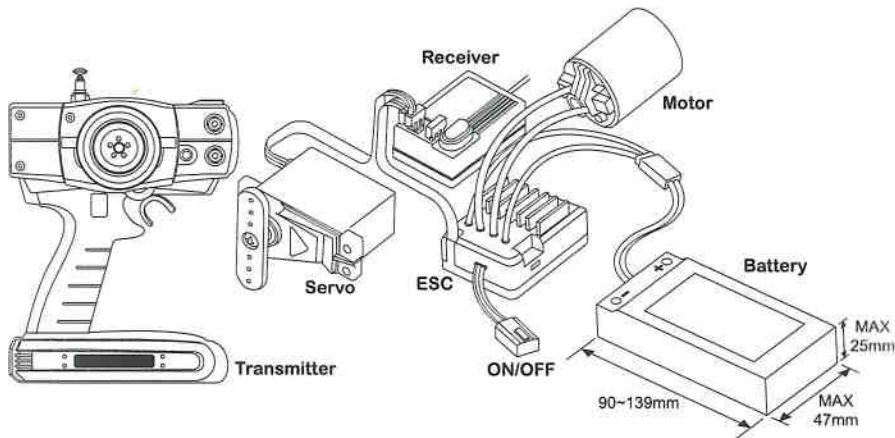

CARTEN M210 EP 1/10 M – CHASSIS

M210 Specification

DRIVETRAIN	Shaft Drive 4WD
Track Width	166mm
Wheelbase	208-210mm
Final Gear Ratio	2.35
Gear Ratio	5.46
Tire Diameter	55mm

Equipped

Full Baering	Aluminum Center Driver Shaft
Stell CVD Drive Shaft	Aluminum Spur Gear Hub
Carbon Fibre Chassis , Upper Deck , Shock Tower	Oil Shocks

Aluminum Motor Mount Ball Differential

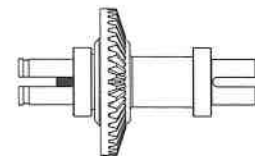

Ball Diff

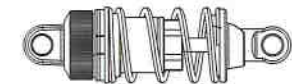

Oil Shock

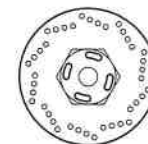

Plastic Hex Hub



Set Screw

CARTEN M210-R EP 1/10 M – CHASSIS

M210-R Specification

DRIVETRAIN	Shaft Drive 4WD
Track Width	166mm
Wheelbase	208-210mm
Final Gear Ratio	2.47
Gear Ratio	4.56
Tire Diameter	55mm

Equipped

Full Baering	Aluminum Spur Gear Hub
Stell CVD Drive Shaf	Aluminum 12mm Hex Hub
Carbon Fibre Chassis , Upper Deck , Shock Tower	Aluminum Shocks
Aluminum Motor Mount	Metal Gear Differential
Aluminum Center Driver Shaft	Full Turnbuckle

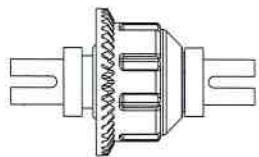

Metal Gear Diff



Aluminum Hex Hub



Aluminum Shock



Turnbuckle

GEAR DIFF

1

- X4
NBA235
5.1×9×0.5mm
- X2
NBA235
5.1×9×0.2mm
- X2
NBA303
4.0mm
- X4
NBA286
M2×8mm
- X2
NBA299
10×15×4mm

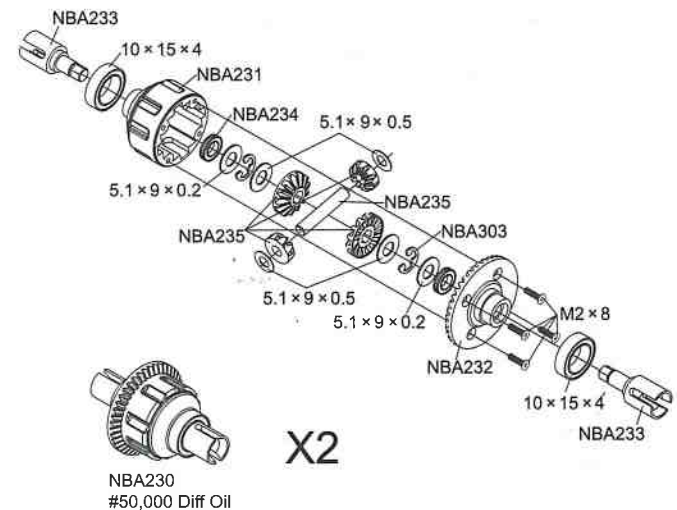

2

- X1
NBA236
- X1
NBA240
2.6×6×3mm
- X2
NBA297
5×8×2.5mm
- X2
NBA299
10×15×4mm
- X1
NBA238
M2.5×22mm
- X1
NBA238
M2.5
- X12
NBA237
3/32"
- NBA236
2.7×5.9×0.5mm

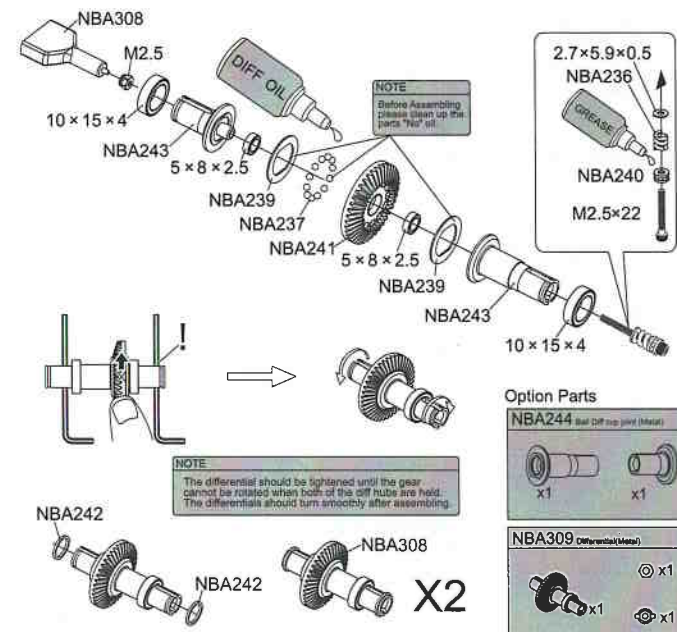

BALL DIFF







Option Parts

NBA244 Ball Diff cap (Metal)

NBA309 Differential (Metal)

ALUMINUM SHOCK

3

-  X1
- NBA222
-  X1
- NBA220
-  X2
- NBA221
2×5×0.5mm
-  X1
- NBA221
-  X1
- NBA219
-  X1
- NBA223
-  X1
- NBA223
-  X1
- NBA223
-  X1
- NBA223

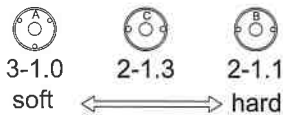
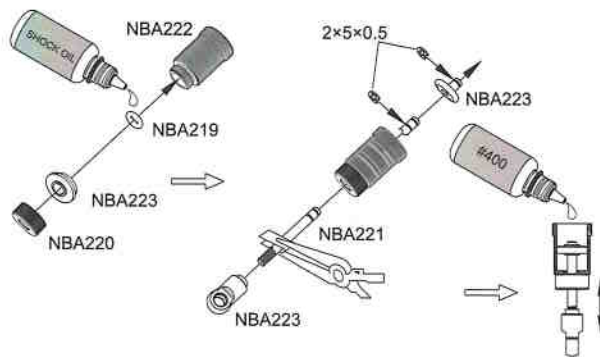

4

-  X1
- NBA220
-  X1
- NBA220
-  X1
- NBA219
11×13×1mm
-  X1
- NBA223
-  X1
- NBA223
-  X1
- NBA219
-  X1
- NBA219

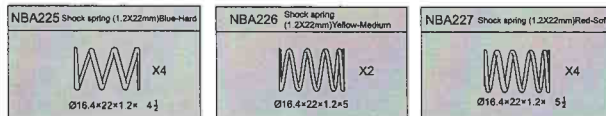
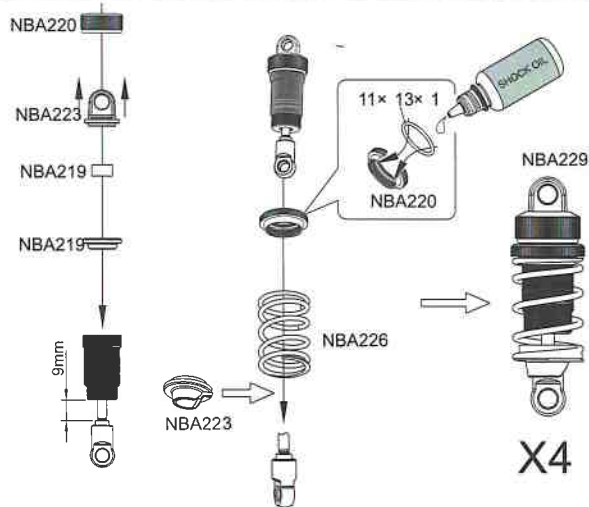



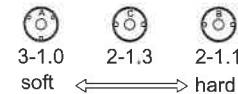
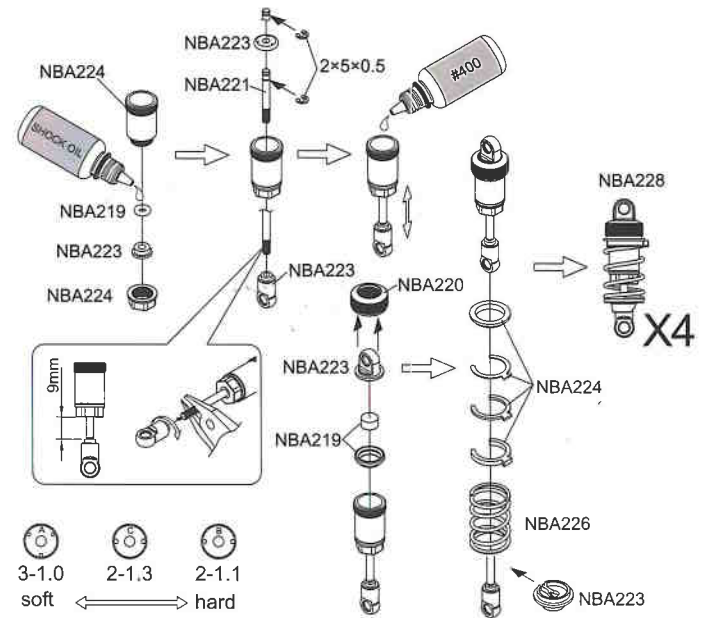

Plastic Oil Shocks

5

-  X2
- NBA221
2×5×0.5mm
-  X1
- NBA221
-  X1
- NBA219
2.9×6.6mm
-  X1
- NBA223
-  X1
- NBA219



6

-  X4
- NBA280
M3×8mm
-  X2
- NBA294
M3
-  X3
- NBA289
M3×8mm
-  X3
- NBA210
3×8mm
-  X2
- NBA209
M3

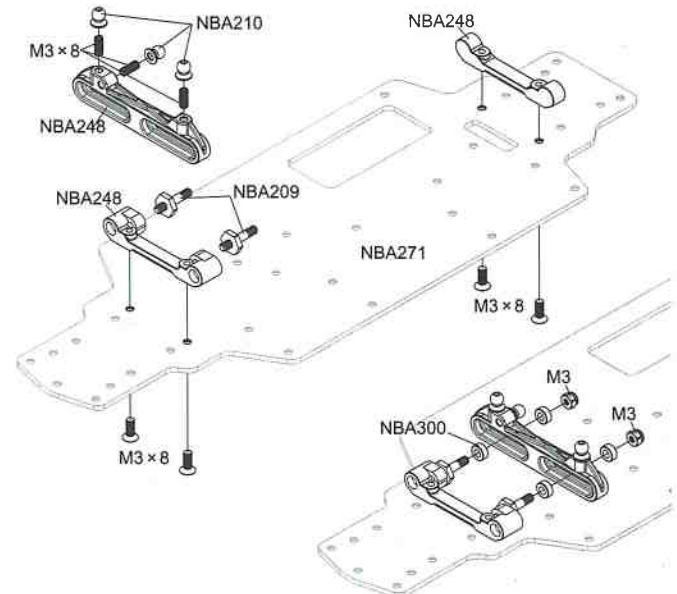

7

 X4

NBA280
M3x8mm

 X4

NBA290
M3x10mm

 X8

NBA211

 X4

NBA214

 X4

NBA289
M3x8mm

 X4

NBA210
3x8mm

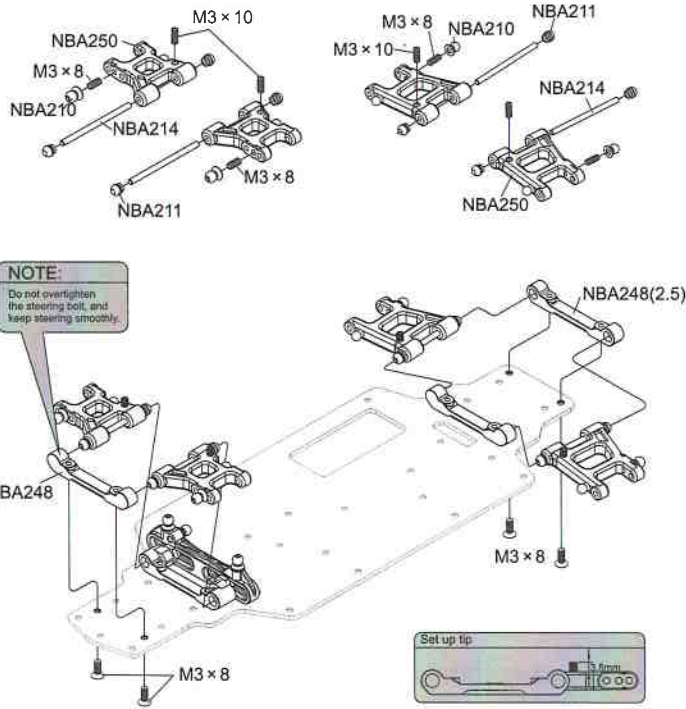

8

 X8

NBA280
M3x8mm

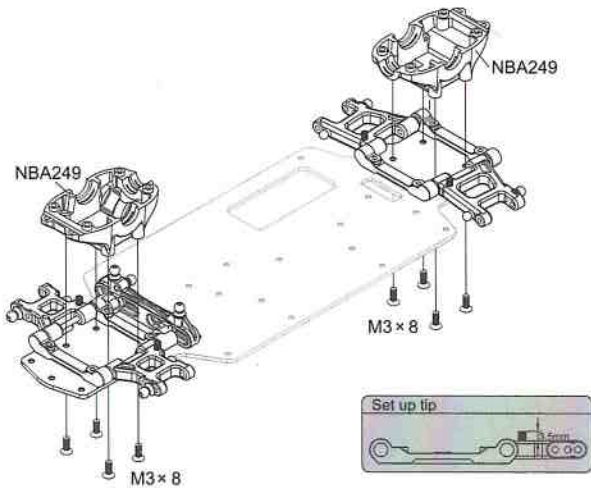

9

 X1

NBA284
M3x12mm

 X1

NBA210
3x8mm

 X1

NBA281
M3x6mm

 X1

NBA254
(Black)

 X2

NBA254
(Silver)

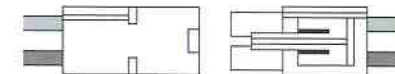
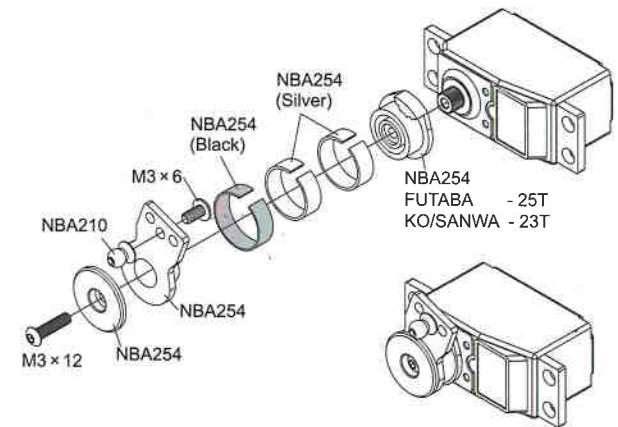

- 1: Switch on transmitter
- 2: Connecting battery and turn on ESC switch

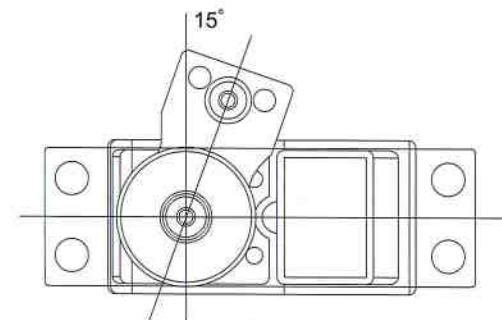

Servo in neutral position and attaching servo saver(15 Degree)

10

■ X8

NBA281
M3×6mm

○ X4

NBA302
3×8×0.5mm

■ X2

NBA280
M3×8mm

■ X2

NBA279
M3×6mm

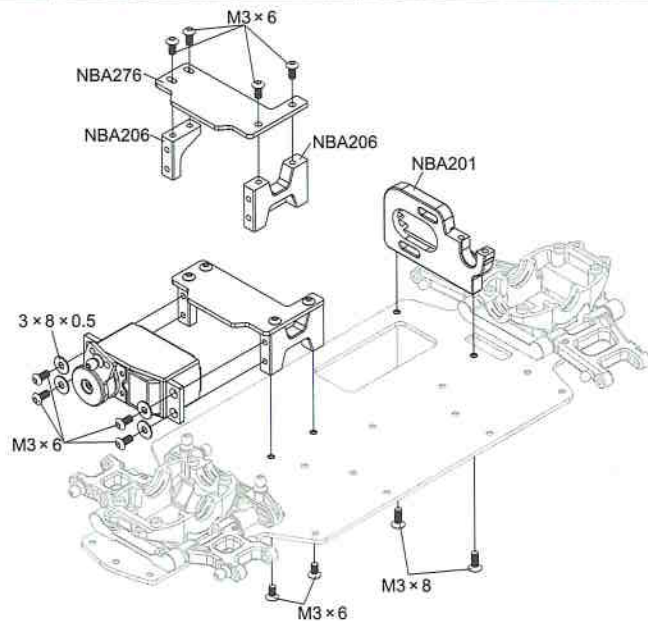

11

■ X1

NBA279
M3×6mm

■ X1

NBA280
M3×8mm

○ X4

NBA298
5×10×4mm

○ X2

NBA306
5.8×9.6×1.9mm

□ X2

NBA255
2×7.6mm

GEAR DIFF

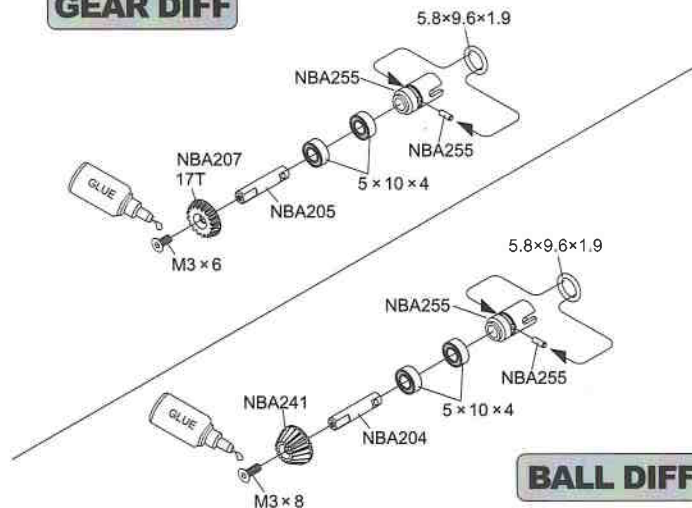

BALL DIFF



12

■ X1

NBA279
M3×6mm

■ X1

NBA280
M3×8mm

○ X6

NBA298
5×10×4mm

○ X2

NBA306
5.8×9.6×1.9mm

□ X2

NBA255
2×7.6mm

■ X8

NBA281
M3×6mm

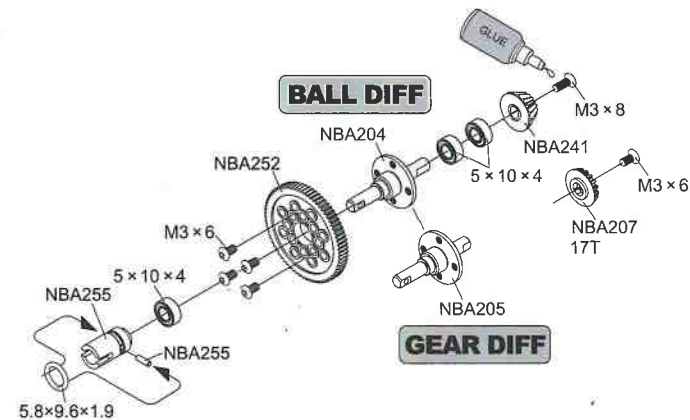

BALL DIFF

GEAR DIFF

13

■ X2

NBA283
M3×10mm

■ X2

NBA282
M3×8mm

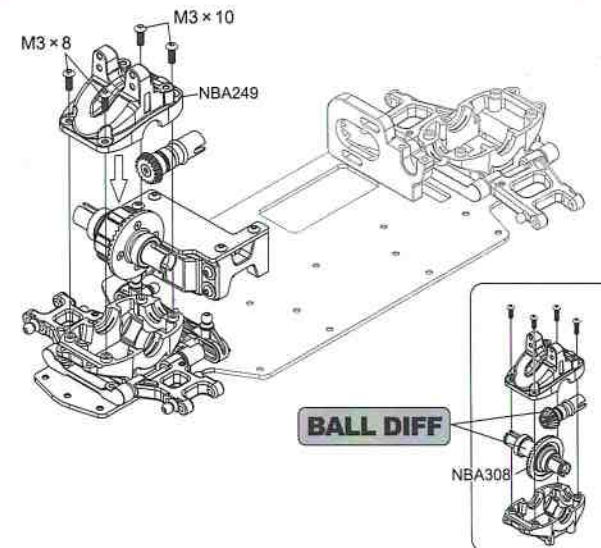

BALL DIFF

NBA308

14

-  X2
NBA283
M3×10mm
-  X2
NBA282
M3×8mm

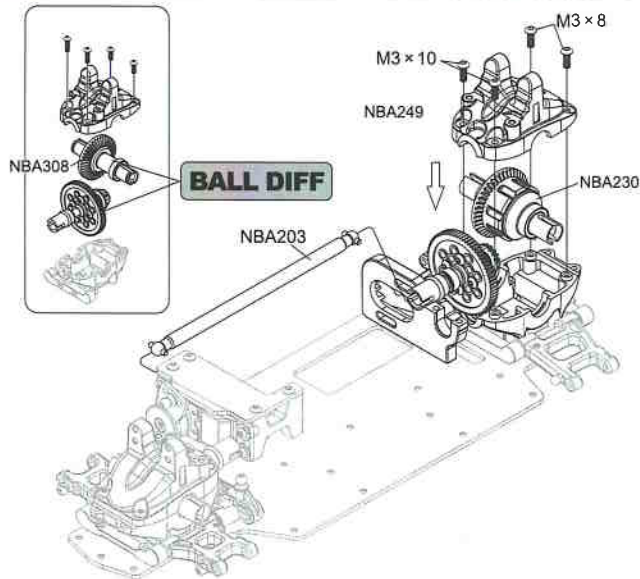

15

-  X2
NBA304
2×10mm
-  X4
NBA298
5×10×4mm
-  X4
NBA283
M3×10mm
-  X4
NBA212
3×7×4.2mm
-  X2
NBA289
M3×8mm
-  X4
NBA210
3×8mm
-  X2
NBA282
M3×8mm
-  X2
NBA287
M3×3mm
-  X4
NBA301
3×6×0.5mm

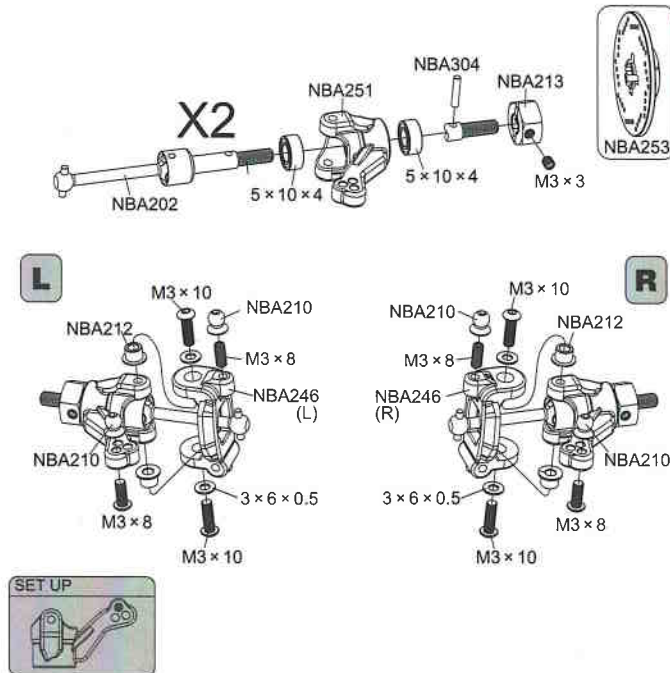

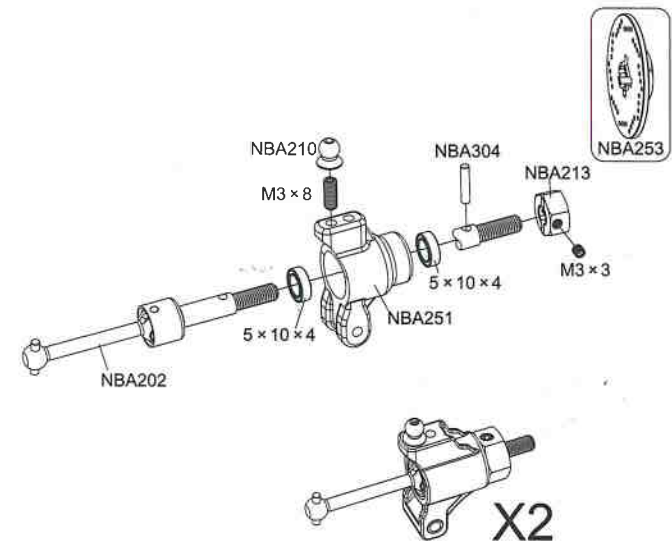

16

-  X4
NBA298
5×10×4mm
-  X2
NBA304
2×10mm
-  X2
NBA289
M3×8mm
-  X2
NBA210
3×8mm
-  X2
NBA287
M3×3mm



17

-  X2
NBA288
M3×4mm
-  X2
NBA214
2.5 × 23mm

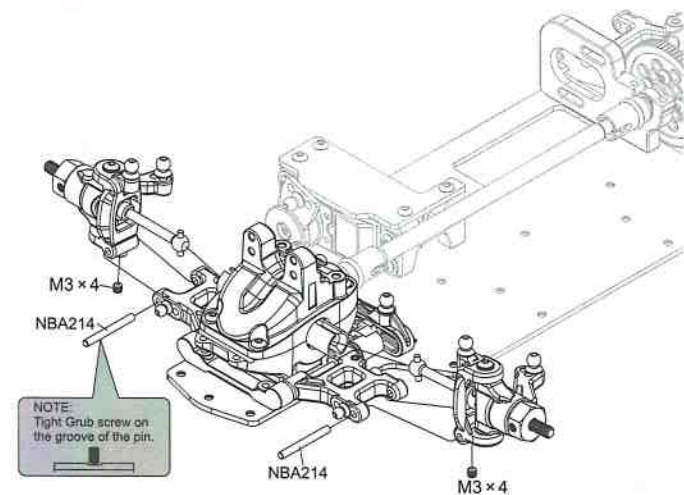

18

— X2

NBA214
2.5×26mm

■ X2
NBA288
M3×4mm

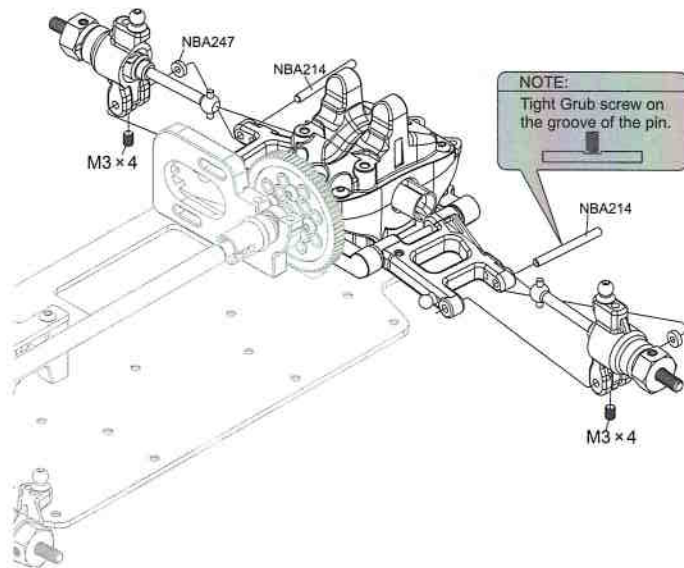

19

— X2

NBA283
M3×10mm

— X4

NBA282
M3×8mm

■ X4

NBA210
3×8mm

— X2

NBA281
M3×6mm

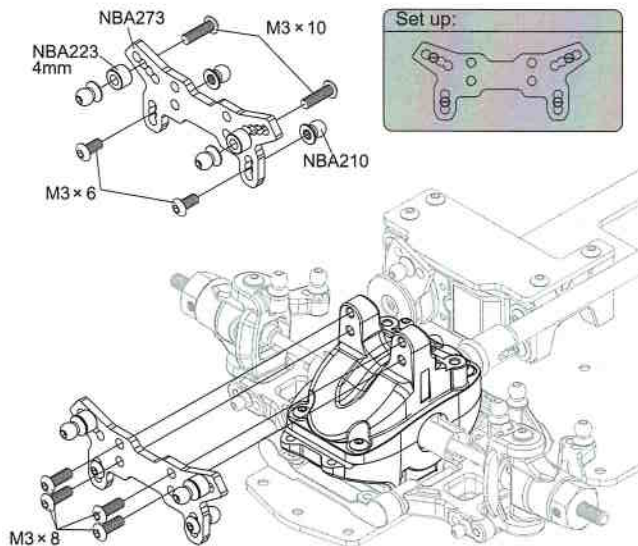

20

— X2

NBA283
M3×10mm

— X6

NBA282
M3×8mm

■ X4

NBA210
3×8mm

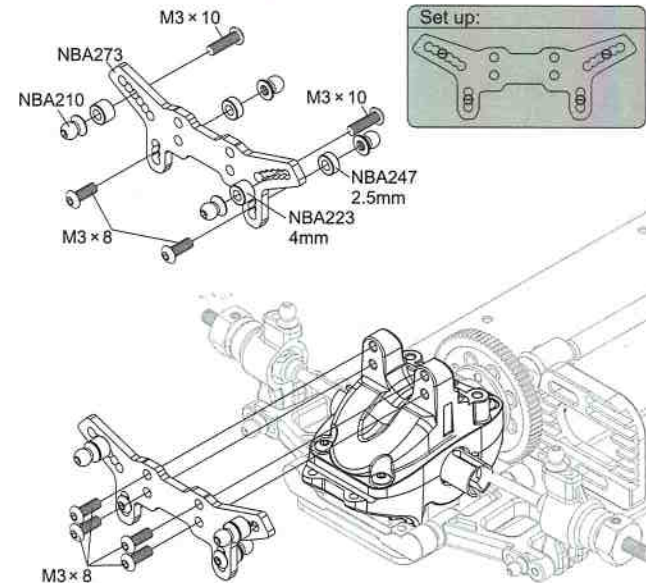

21

○ X14

NBA247

— X2

NBA208
M3×12mm

— X4

NBA208
M3×19mm

— X1

NBA289
M3×8mm

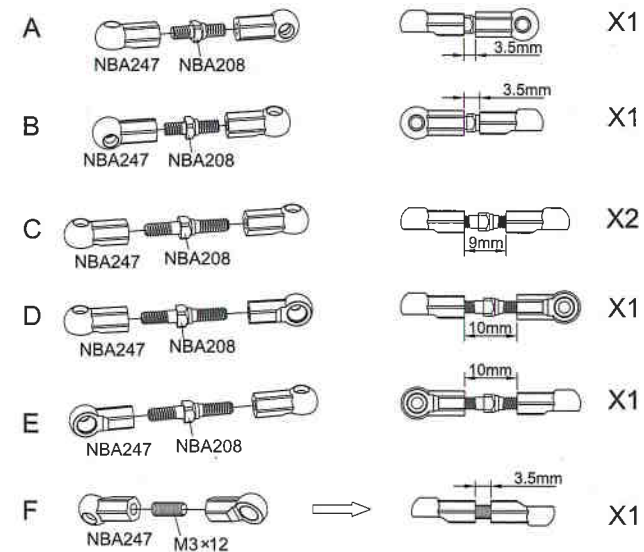

22

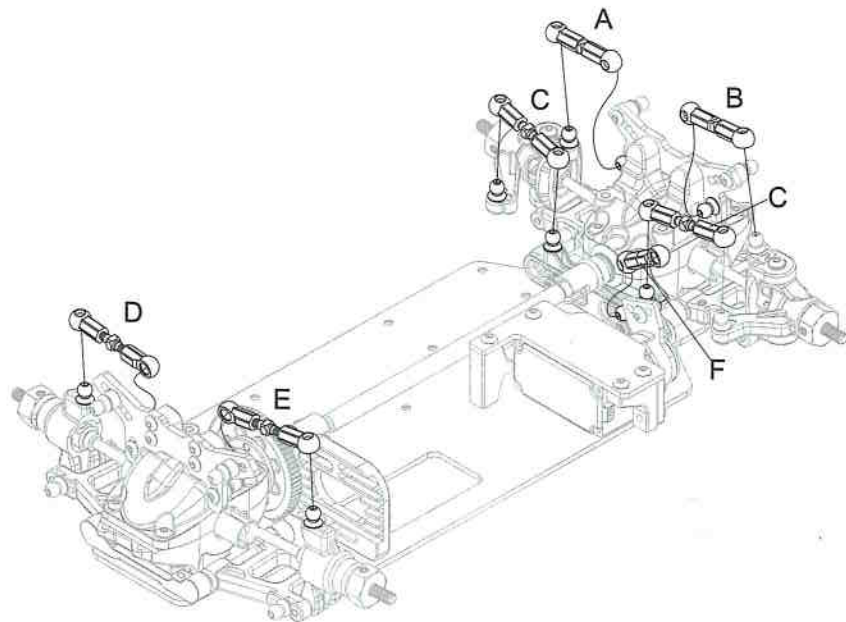

23

X6
NBA279
M3×6mm

X4
NBA281
M3×6mm

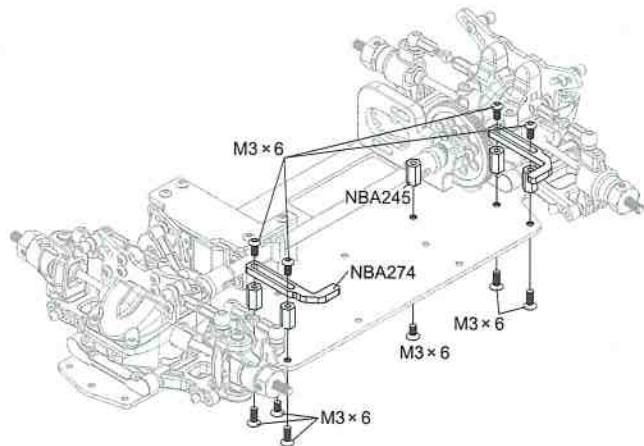

0 1 2 3 4 5

24

X4

NBA282
M3×8mm

X2

NBA285
M3×18mm

X4

NBA283
M3×10mm

X1

NBA288
M3×4mm

X9

NBA281
M3×6mm

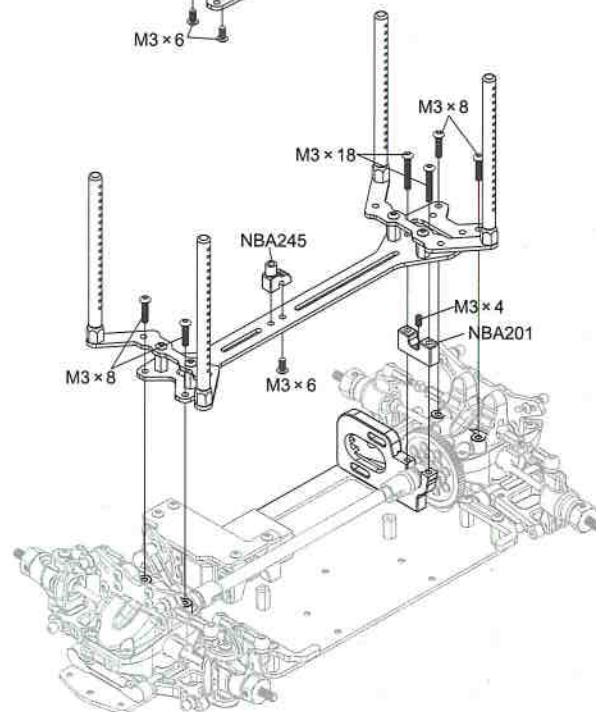
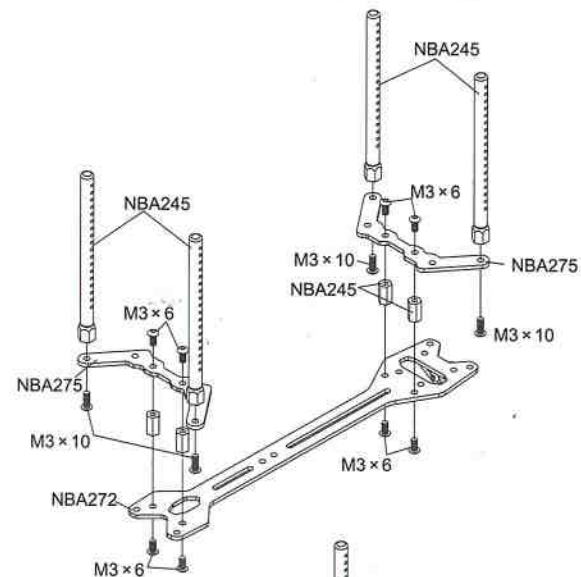

25

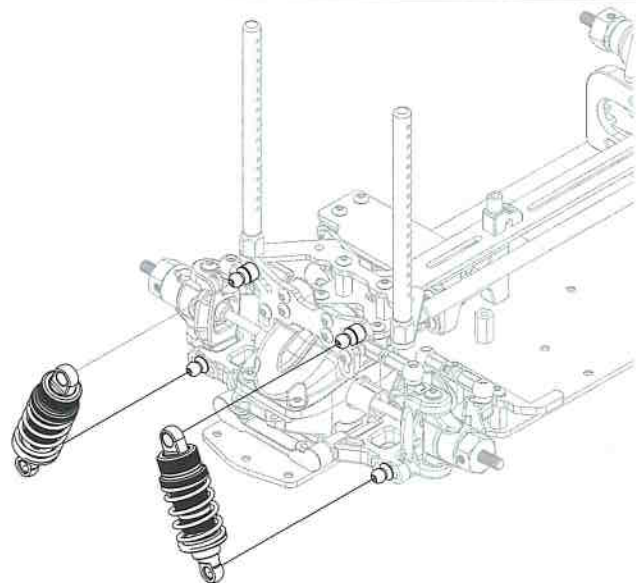

26

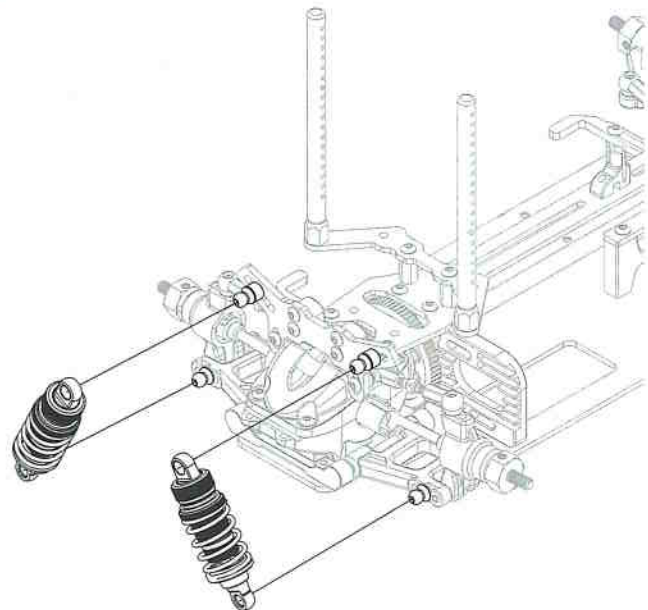

27

X3

NBA280
M3×8mm

X2

NBA282
M3×8mm

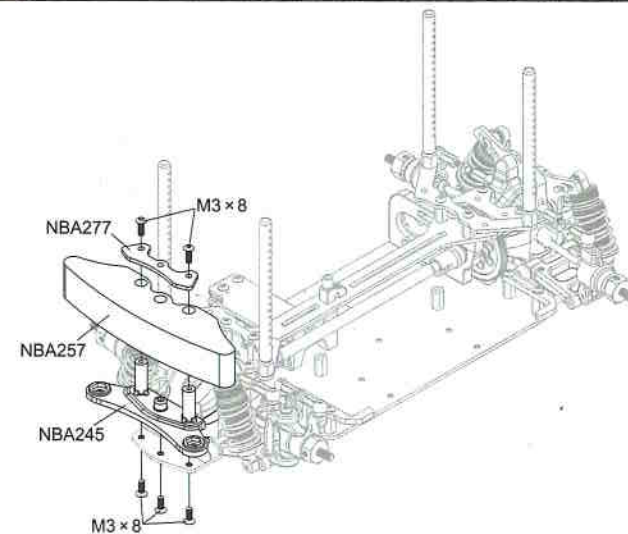

28

X2

NBA283
M3×10mm

X2

NBA302
3×8×0.5

X1

NBA287
M3×3mm

M210 GEAR RATIO

SPUR GAER	BALL DIFF (40/17)	GEAR DIFF (42/17)
72	2.353	2.47
PINION GEAR	BALL DIFF GEAR RATIO	GEAR DIFF GEAR RATIO
21	8.07	8.47
22	7.70	8.08
23	7.37	7.73
24	7.06	7.41
25	6.78	7.11
26	6.52	6.84
27	6.27	6.59
28	6.05	6.35
29	5.84	6.13
30	5.65	5.93
31	5.47	5.74
32	5.29	5.56
33	5.13	5.39
34	4.98	5.23
35	4.84	5.08
36	4.71	4.94
37	4.58	4.81
38	4.46	4.68
39	4.34	4.56
40	4.24	4.45
41	4.13	4.34
42	4.03	4.23
43	3.94	4.14
44	3.85	4.04

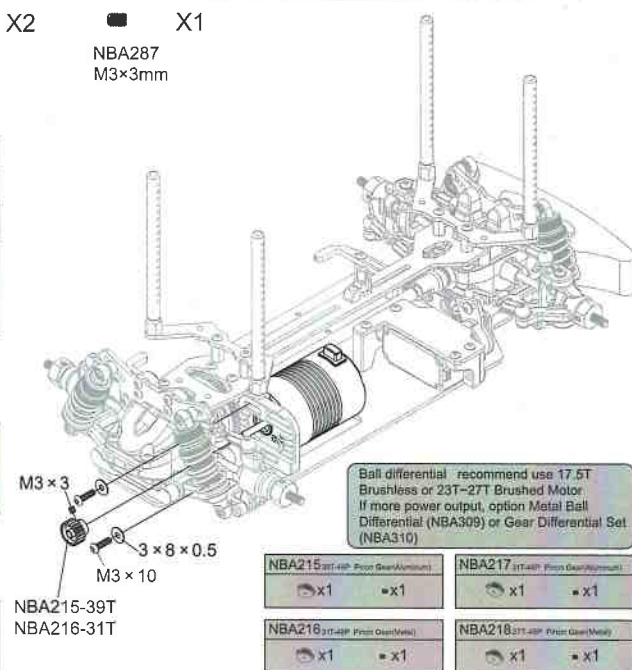

Ball differential recommend use 17.5T Brushless or 23T-27T Brushed Motor. If more power output, option Metal Ball Differential (NBA309) or Gear Differential Set (NBA310).

NBA215 39T-40P From Gear(Armature)	NBA217 31T-40P From Gear(Armature)
x1	x1
NBA216 31T-40P From Gear(New)	NBA218 31T-40P From Gear(New)
x1	x1

29

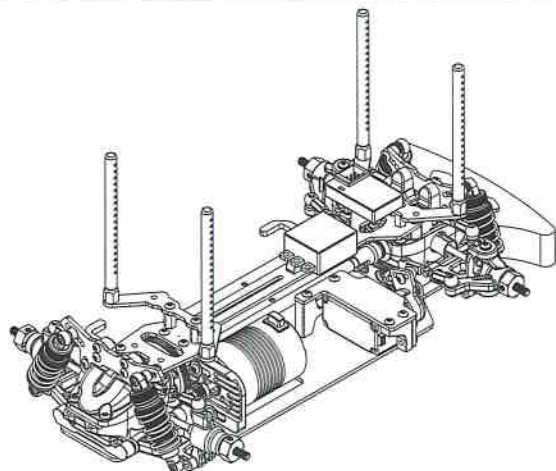

30

 X4
NBA295
M4

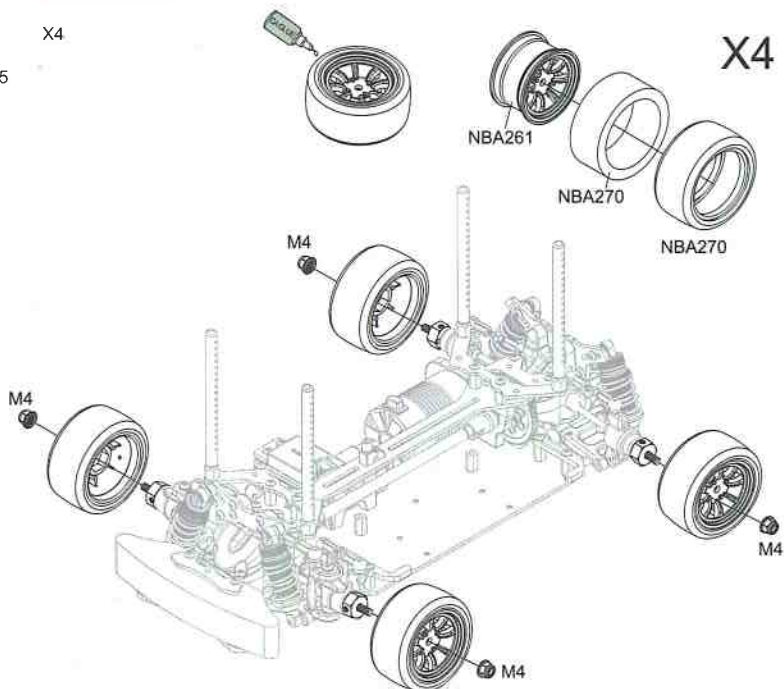

X4



31

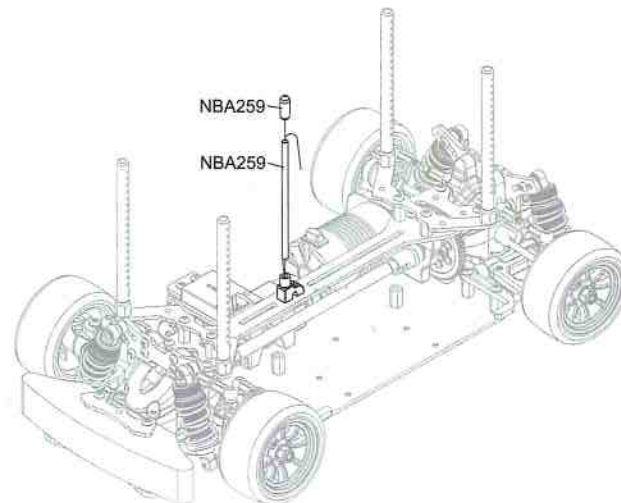

32

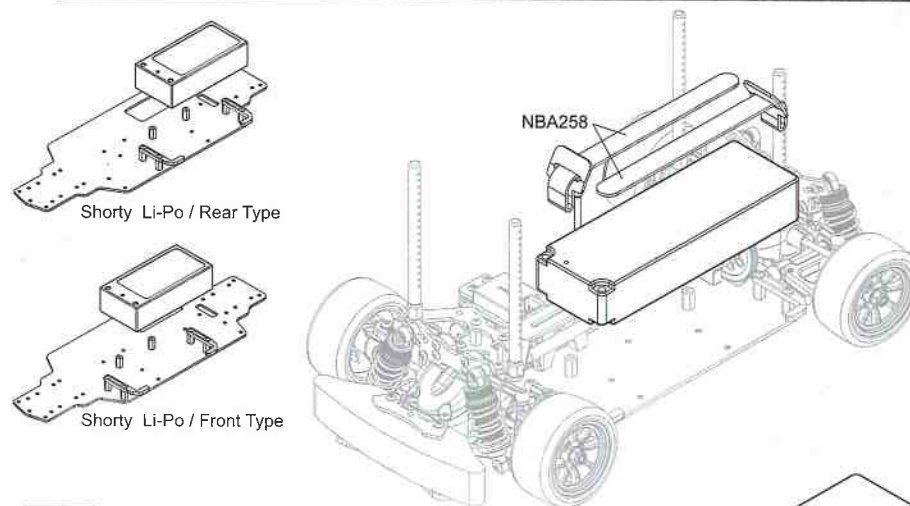

Front



Rear

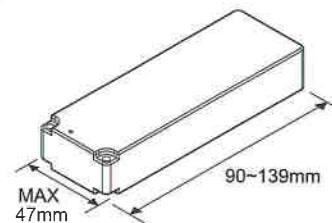

NBA305 X8

NBA305



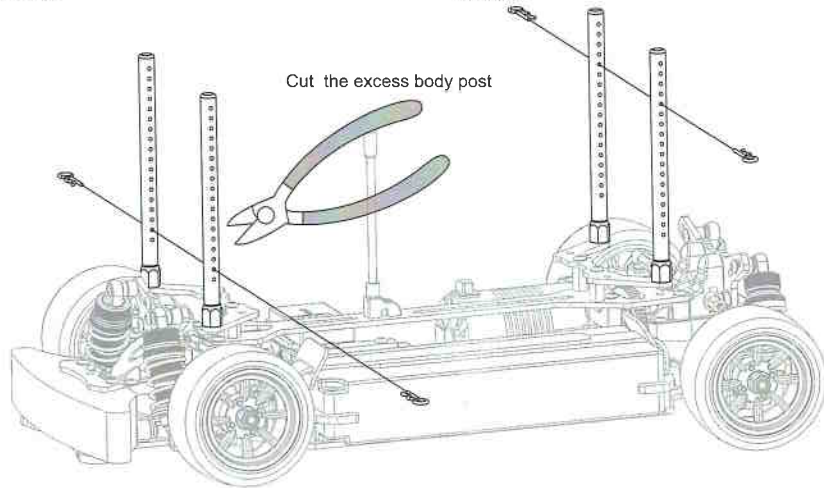







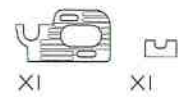
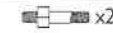

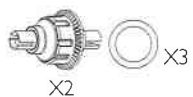
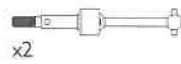



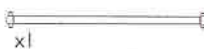





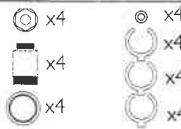

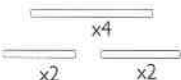

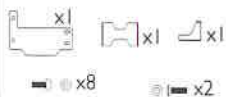



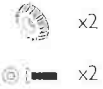

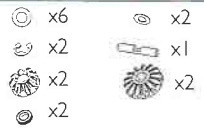
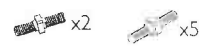

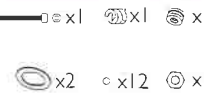
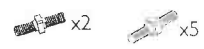
Cut the excess body post

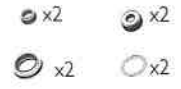

NBA802

NBA801

NBA803

NBA201 Motor Mount  X1 X1	NBA209 Steering Bolt  x2	NBA221 Shock shafts  x8	NBA230 Gear Differential  X2 X3
NBA202 Universal Shafts  x2	NBA210 4.8x6 mm Ball Stud  x10	NBA222 Shock Body(Aluminum)  x2	NBA231 Gear Diff Case  x1 x4
NBA203 Center Drive Shaft (210mm Chassis)  x1	NBA211 Pivot Ball Stud  x10	NBA223 Shock Parts  x2 x2 x2 x2 x2 x2 x2 x2	NBA232 42T Bevel Gear (Metal)  x1 x4
NBA204 Drive Shaft And Spur Gear Hub (For Ball Diff)  x1 x1	NBA212 steering Bush  x4	NBA213 12MM Hex Hub  x4 x4	NBA224 Plastic Shock  x4 x4 x4 x4 x4 x4
NBA205 Drive Shaft And Spur Gear Hub (For Gear Diff)  x1 x1	NBA214 Suspension Shaft Set  x4 x2 x2	NBA225 Shock spring(1.2X22mm)Blue-Hard.  x4	NBA233 Gear Diff Cup Joint  x2
NBA206 Servo Mount Set  x1 x1 x1 x8 x2	NBA215 31T-48P Pinion Gear (Aluminum)  x1 x1	NBA226 Shock spring (1.2X22mm)Yellow-Medium  x4	NBA234 Gear Diff Oring  x4
NBA207 17T Metal Bevel Gear(Gear Diff)  x2 x2	NBA216 31T-48P Pinion Gear(Metal)  x1 x1	NBA227 Shock spring (1.2X22mm)Red-Soft  x4	NBA235 Gear Diff Bevel Gear Set  x6 x2 x2 x1 x2 x2 x2
NBA208 Tumbuckle Set (M3x12 / M3x19)  x2 x5	NBA217 31T-48P Pinion Gear (Aluminum)  x1 x1	NBA228 Shock Set(Plastic)  x4 x4	NBA236 Ball Diff Parts Set  x1 x1 x1 x2 x12 x1
NBA209 Tumbuckle Set (M3x12 / M3x19)  x2 x5	NBA218 27T-48P Pinion Gear (Metal)  x1 x1	NBA229 Shock Set(Aluminum)  x4 x4	NBA237 Diff Ball (3/32)  x12
	NBA219 Shock Parts(O-rings)  x4 x8 x4 x4	NBA240 Thrust Bearing  x2	NBA238 Ball Diff Screw Set  x1 x1
	NBA220 Shock Body parts(Aluminum)  x2 x2 x2 x2	NBA241 Diff gears(Ball Diff)  x1 x1	NBA239 Ball Diff Shim  x2
		NBA242 Diff O-rings(Ball Diff)  x4	

NBA243 Ball Diff cup joint (Plastic) x1	NBA254 Servo Saver x1 x1 x2 x1	NBA263 8 Spoke Wheel +4mm (Silver) x4	NBA271 Main Chassis x1
NBA244 Ball Diff cup joint (Metal) x1 x1	NBA255 Cup Jiont x3 x2 x2	NBA264 6 Spoke Wheel +4mm (Gray) x4	NBA272 Upper Deck x1
NBA245 Front Bumper Hold And Body Mount x1 x1 x4	NBA256 Bumper For Sedan Body x1	NBA265 8 Spoke Wheel +4mm (Black) x4	NBA274 Battery Holder x2
NBA246 Front Hub Carrier L/R x1 x1	NBA257 Bumper For Hatchback Body x1	NBA266 10 Spoke Wheel +1mm (Silver) x4	NBA276 Servo Plate x1
NBA247 Ball End (4.8mm) x8 x2	NBA258 Battery Strap x2	NBA267 10 Spoke Wheel +1mm (Gray) x4	NBA277 Bumper Plate (For Hatchback Body) x1
NBA248 Suspension Mount Parts x2 x1 x1	NBA259 Antenna Pipe x1 x1	NBA268 10 Spoke Wheel +3mm (Silver) x4	NBA278 Bumper Plate (For Sedan Body) x1
NBA249 Gear box x2 x2	NBA260 8 Spoke Wheel +1mm (Silver) x4	NBA269 10 Spoke Wheel +4mm (Gray) x4	NBA279 Screw Set-FH M3x6 x10
NBA250 Arms Set (F and R) x2 x2	NBA261 8 Spoke Wheel +1mm (Gray) x4	NBA281 Screw Set-BH M3x6 x10	NBA280 Screw Set-FH M3x8 x10
NBA251 Hub carrier x2 x2	NBA262 8 Spoke Wheel +1mm (Black) x4	NBA270 Tires x4 x4	NBA282 Screw Set-BH M3x8 x10
NBA252 Spur Gear 72T x1	NBA283 Screw Set-BH M3x10 x10	NBA284 Screw Set-BH M3x12 x10	
NBA253 Hex Hub (5MM) x4 x4			

NBA285 Screw Set-BH M3x18 x10	NBA301 Washer(3*6.5*0.5mm) x10	NBA309 Differential(Metal) x1 x1	NBA311 Sway Bar x1 x1 x1 x1 x8 x2 x4 x4 x4 x4
NBA286 Screw Set-FH M2x8 x10	NBA302 Washer(3*8*0.5mm) x10	NBA310 Gear Differential Set x2 x3 x2 x2 x1 x1	
NBA287 Set Screw M3x3 x10	NBA303 E-Clip x5		
NBA288 Set Screw M3x4 x10	NBA304 Pin2X10 x10		
NBA289 Set Screw M3x8 x10	NBA305 Body pinS x12		
NBA290 Set Screw M3x10 x4	NBA306 O-Ring x10		
NBA291 Set Screw M3x12 x10	NBA307 Washer(11*14*0.2mm) x10		
NBA292 Set Screw M3x18 x10	NBA308 Differential(Plastic) x2 x1		
NBA293 Set Screw M3x20 x10			
NBA294 M3 Nut x10			
NBA295 M4 Nut x4			
NBA296 Bearing 3x6x2.5 x4			
NBA297 Bearing 5*8*2.5 x2			
NBA298 Bearing 5x10x4 x8			
NBA299 Bearing 10x15x4 x4			
NBA300 Spacer Set 3x6x2.5 x4			

