

Bodyshell: _____ **Thickness:** _____ **Track Conditions**
Driver: _____ **Date:** _____ **Composition:** Asphalt Carpet
Event: _____ **Track:** _____ **Layout:** Open Mixed Technical
Car: _____ **Motor:** _____ **Traction:** Low Medium High

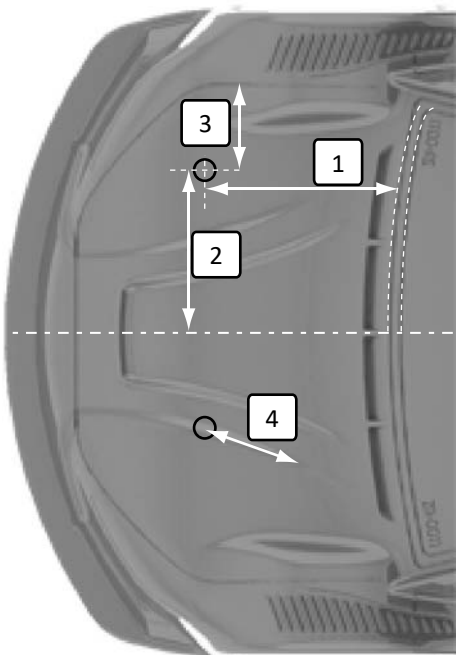
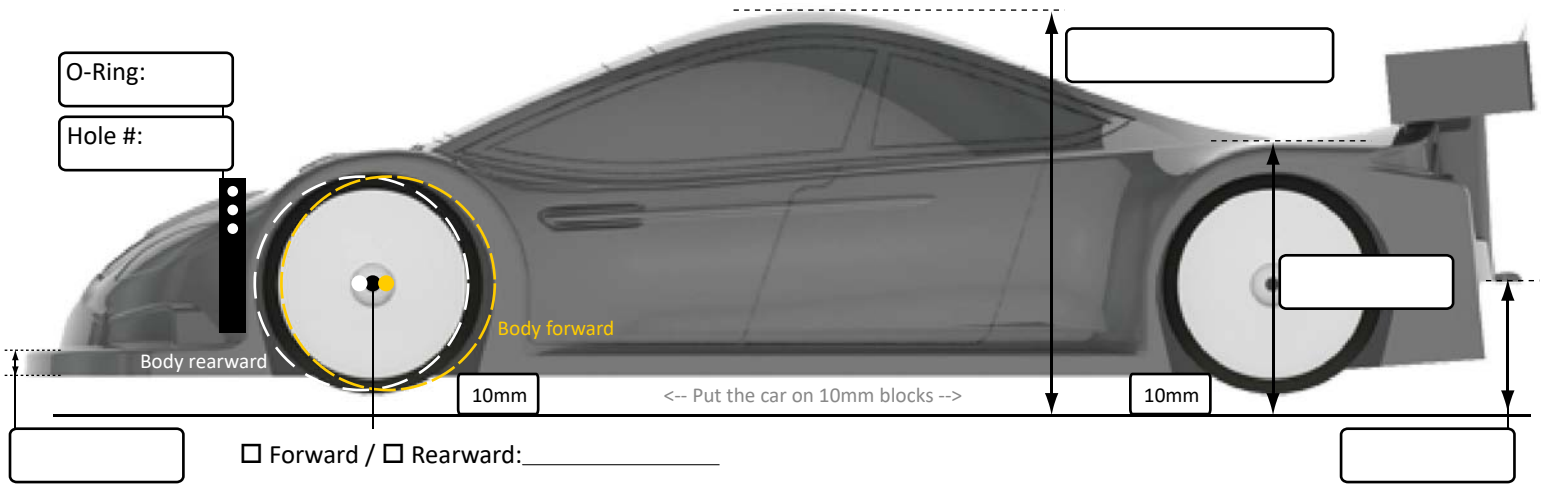

Front

- From base of windshield (1): _____
- From centerline (2): _____
- Center-to-Center: _____
- From hood molding line (3): _____
- From back of molding line (4): _____

Rear

- From back of wing mount (5): _____
- From centerline (6): _____
- From trunk line inwards (7): _____
- From "mounting help" line outwards: _____
- Horizontal Body Mount

Body Weight (Track ready): _____

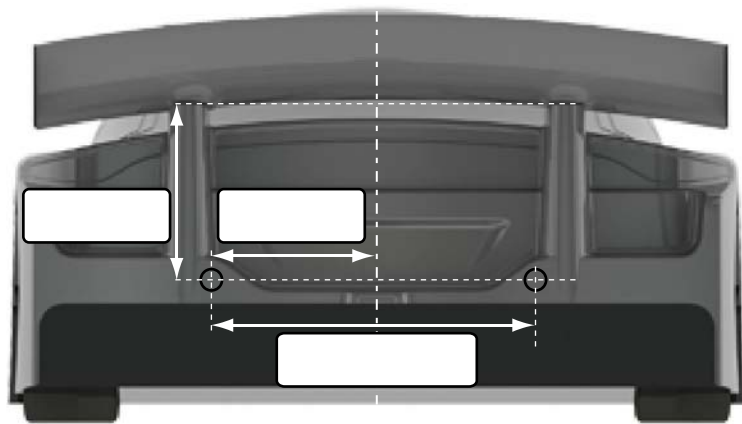
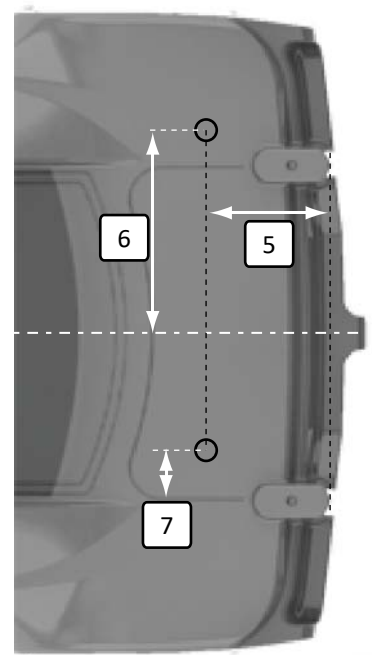

Wing: _____
 Winglets: Yes No

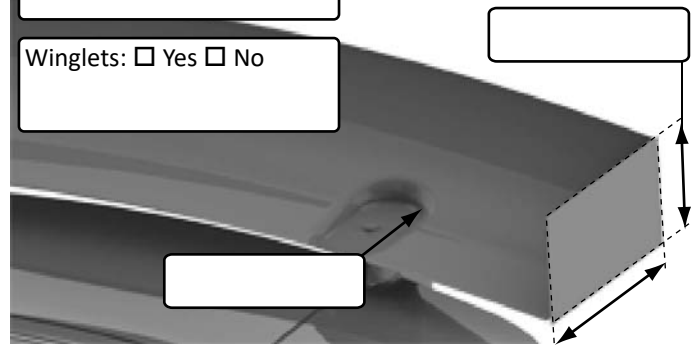

Notes