

**Bodyshell:** \_\_\_\_\_ **Thickness:** \_\_\_\_\_ **Track Conditions**  
**Driver:** \_\_\_\_\_ **Date:** \_\_\_\_\_ **Composition:**  Asphalt  Carpet  
**Event:** \_\_\_\_\_ **Track:** \_\_\_\_\_ **Layout:**  Open  Mixed  Technical  
**Car:** \_\_\_\_\_ **Motor:** \_\_\_\_\_ **Traction:**  Low  Medium  High

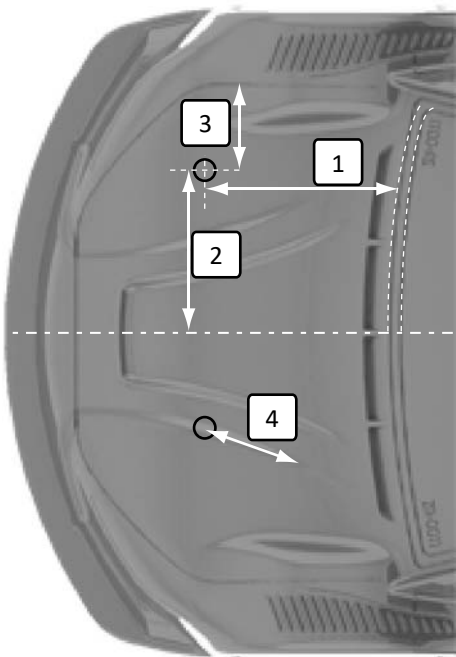
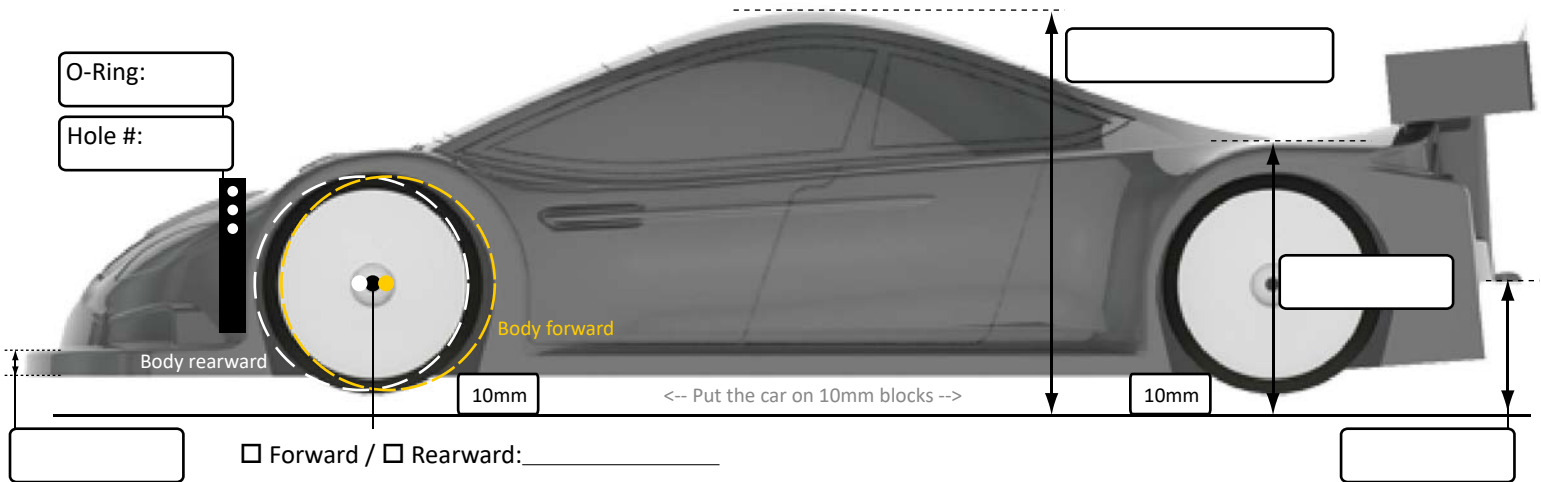

**Front**

- From base of windshield (1): \_\_\_\_\_
- From centerline (2): \_\_\_\_\_
- Center-to-Center: \_\_\_\_\_
- From hood molding line (3): \_\_\_\_\_
- From back of molding line (4): \_\_\_\_\_

**Rear**

- From back of wing mount (5): \_\_\_\_\_
- From centerline (6): \_\_\_\_\_
- From trunk line inwards (7): \_\_\_\_\_
- From "mounting help" line outwards: \_\_\_\_\_
- Horizontal Body Mount

Body Weight (Track ready): \_\_\_\_\_

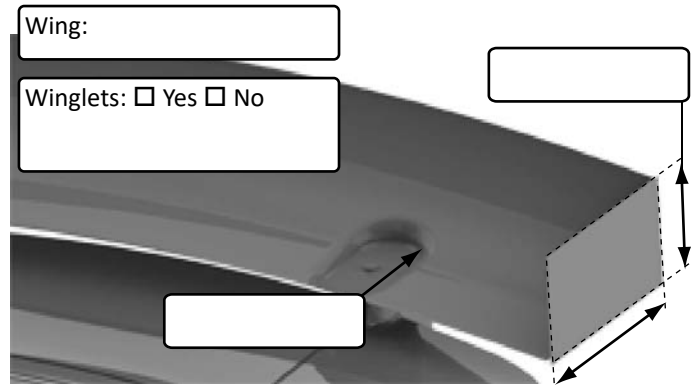
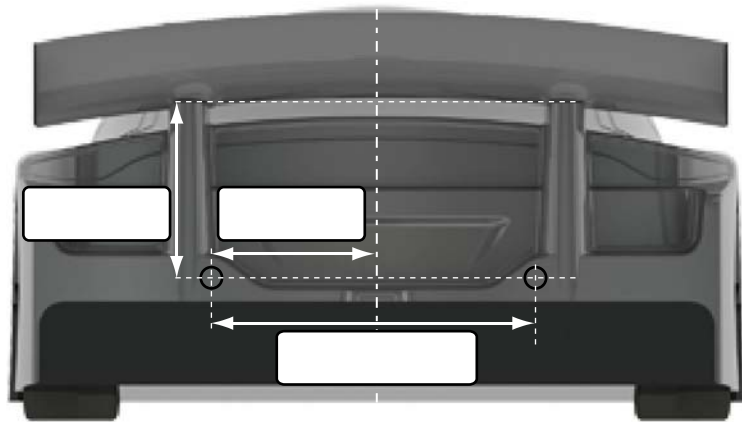
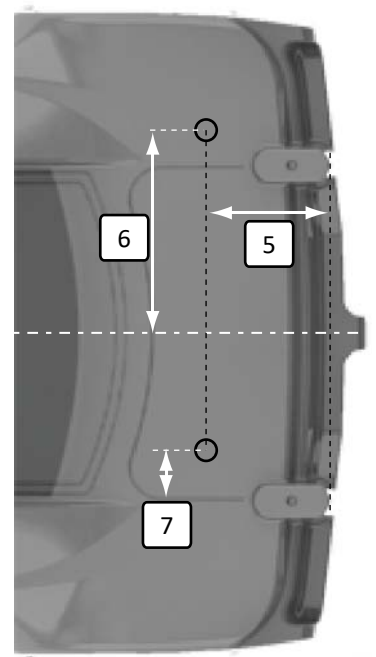

**Notes**