

NAME \_\_\_\_\_  
 COUNTRY \_\_\_\_\_  
 RACE \_\_\_\_\_  
 TRACK \_\_\_\_\_

DATE \_\_\_\_\_ TEMP. °C AIR / TRACK \_\_\_\_\_ /  
 ASPHALT  OUTDOOR  INDOOR  CARPET   
 TRACK CONDITION TECHNICAL  MIXED  FAST   
 TRACTION LOW  MEDIUM  HIGH

### FRONT

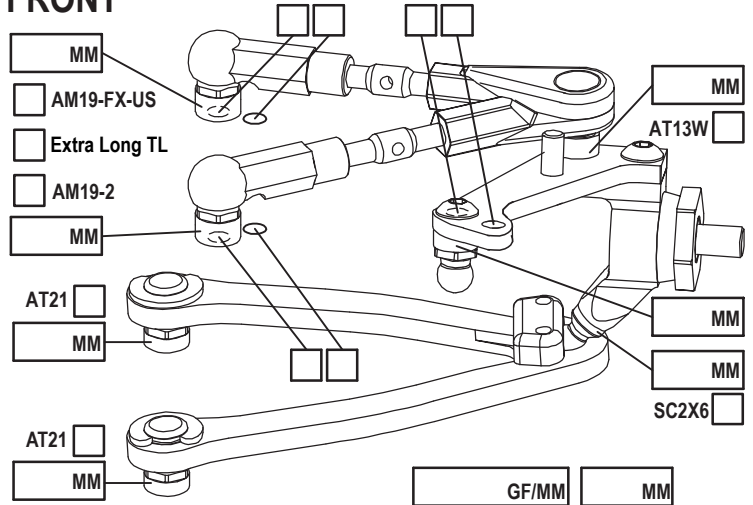

CAMBER ANGLE / ° \_\_\_\_\_  
 CASTER ANGLE / ° \_\_\_\_\_  
 TOE ANGLE / ° \_\_\_\_\_  
 RIDE HEIGHT / MM \_\_\_\_\_  
 DOWNSTOP / MM \_\_\_\_\_  
 UPWNSTOP / MM \_\_\_\_\_  
 STABILIZER Ø / MM \_\_\_\_\_

LOW ARM C04M1+9.0    
 STEER. ARM AM14LS    
 WHEEL SPACER / MM \_\_\_\_\_

FRONT DRIVE SPOOL  GB2B  LOW  HIGH   
 DIFF. OIL \_\_\_\_\_ DIFF WASHERS \_\_\_\_\_

WHEELHUB AM06WL

**SHOCKS SET**

|              |      |                          |                              |
|--------------|------|--------------------------|------------------------------|
| ROTOR        | STD  | <input type="checkbox"/> | <input type="checkbox"/>     |
| SPRING       | STD  | <input type="checkbox"/> | S <input type="checkbox"/>   |
| DAMPER       | D2.2 | <input type="checkbox"/> | <input type="checkbox"/>     |
| SRS/RHS ARR. | I    | <input type="checkbox"/> | II <input type="checkbox"/>  |
| PSS SETUP    | 25%  | <input type="checkbox"/> | 15% <input type="checkbox"/> |

### REAR

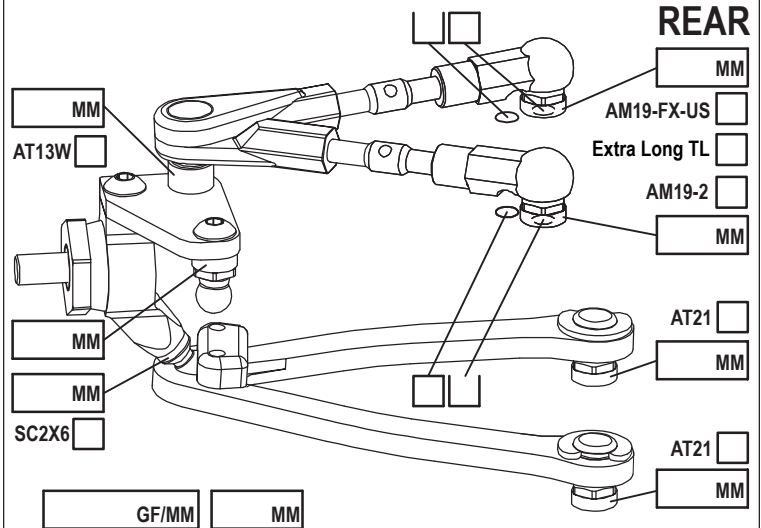

CAMBER ANGLE / ° \_\_\_\_\_  
 CASTER ANGLE / ° \_\_\_\_\_  
 TOE ANGLE / ° \_\_\_\_\_  
 RIDE HEIGHT / MM \_\_\_\_\_  
 DOWNSTOP / MM \_\_\_\_\_  
 UPWNSTOP / MM \_\_\_\_\_  
 STABILIZER Ø / MM \_\_\_\_\_

LOW ARM C04M1+8.0    
 STEER. ARM AM23-1    
 WHEEL SPACER / MM \_\_\_\_\_

REAR DRIVE GB2B  LOW  HIGH   
 DIFF. OIL \_\_\_\_\_ DIFF WASHERS \_\_\_\_\_

WHEELHUB AM06WL

**SHOCKS SET**

|              |      |                          |                              |
|--------------|------|--------------------------|------------------------------|
| ROTOR        | STD  | <input type="checkbox"/> | <input type="checkbox"/>     |
| SPRING       | STD  | <input type="checkbox"/> | S <input type="checkbox"/>   |
| DAMPER       | D2.2 | <input type="checkbox"/> | <input type="checkbox"/>     |
| SRS/RHS ARR. | I    | <input type="checkbox"/> | II <input type="checkbox"/>  |
| PSS SETUP    | 25%  | <input type="checkbox"/> | 15% <input type="checkbox"/> |

### CHASSIS FLEX AND WEIGHT SETTINGS

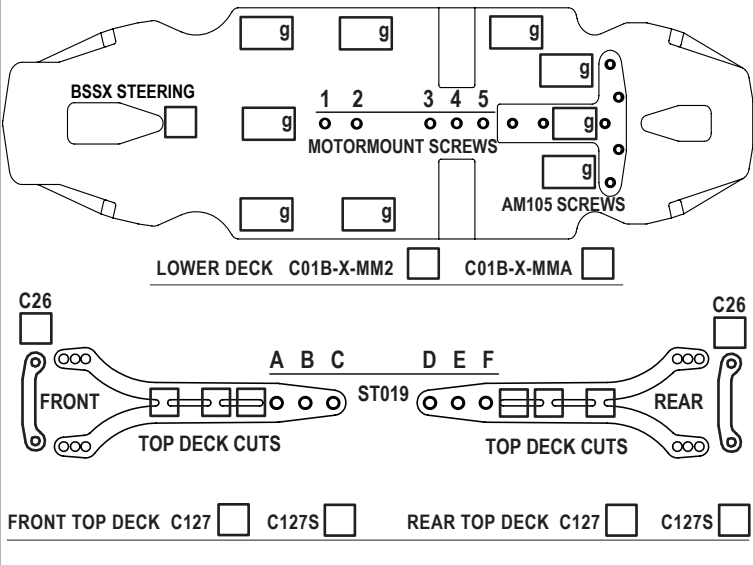

### TIRES

INSERTS \_\_\_\_\_

WHEELS \_\_\_\_\_

ADDITIVE \_\_\_\_\_ TIME - FR \_\_\_\_\_ RR \_\_\_\_\_

TOTAL WEIGHT \_\_\_\_\_ WEIGHT DISTRIBUTION F % R %

NOTES: \_\_\_\_\_

MOTOR LATERAL SHIFT / MM \_\_\_\_\_

ACKERMANN POSITION \_\_\_\_\_

MOTOR \_\_\_\_\_

SERVO \_\_\_\_\_

SPUR PINION RATIO \_\_\_\_\_

STEER TRAVEL IN \_\_\_\_\_ OUT \_\_\_\_\_

BODY \_\_\_\_\_

BATTERY \_\_\_\_\_

WING \_\_\_\_\_

RECEIVER \_\_\_\_\_

ESC \_\_\_\_\_

RADIO \_\_\_\_\_

ESC SETTING \_\_\_\_\_

BEST LAP TIME \_\_\_\_\_ QUALIF./FINAL POSITION \_\_\_\_\_ /