

NAME _____
 COUNTRY _____
 RACE _____
 TRACK _____

DATE _____ TEMP. °C AIR / TRACK _____ /
 ASPHALT OUTDOOR INDOOR CARPET
 TRACK CONDITION TECHNICAL MIXED FAST
 TRACTION LOW MEDIUM HIGH

FRONT

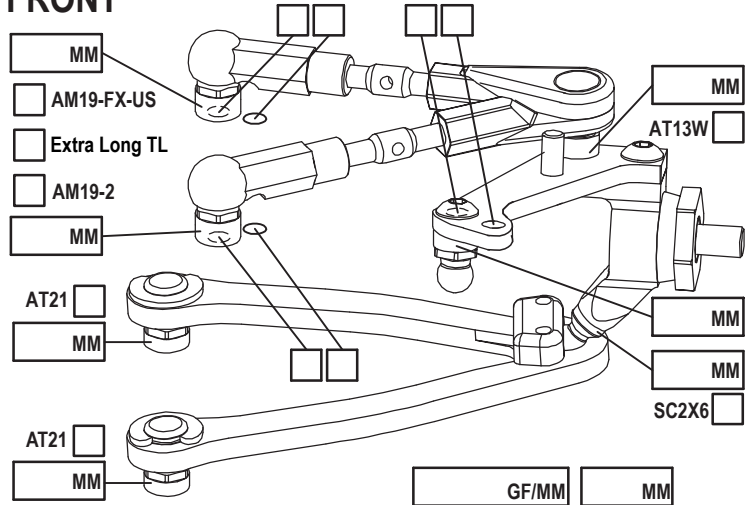

CAMBER ANGLE / ° _____
 CASTER ANGLE / ° _____
 TOE ANGLE / ° _____
 RIDE HEIGHT / MM _____
 DOWNSTOP / MM _____
 UPWNSTOP / MM _____
 STABILIZER Ø / MM _____

LOW ARM C04M1+9.0
 STEER. ARM AM14LS
 WHEEL SPACER / MM _____

FRONT DRIVE SPOOL GB2B LOW HIGH
 DIFF. OIL _____ DIFF WASHERS _____

WHEELHUB AM06WL

SHOCKS SET

ROTOR	STD	<input type="checkbox"/>	<input type="checkbox"/>
SPRING	STD	<input type="checkbox"/>	S <input type="checkbox"/>
DAMPER	D2.2	<input type="checkbox"/>	<input type="checkbox"/>
SRS/RHS ARR.	I	<input type="checkbox"/>	II <input type="checkbox"/>
PSS SETUP	25%	<input type="checkbox"/>	15% <input type="checkbox"/>

REAR

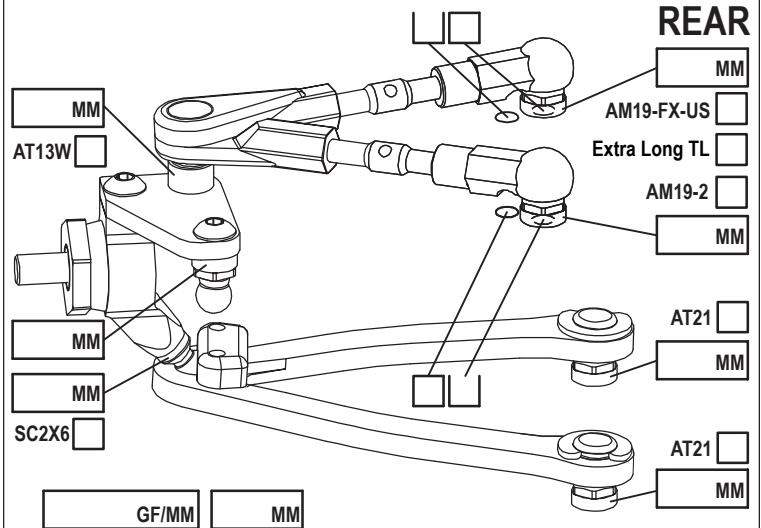

CAMBER ANGLE / ° _____
 CASTER ANGLE / ° _____
 TOE ANGLE / ° _____
 RIDE HEIGHT / MM _____
 DOWNSTOP / MM _____
 UPWNSTOP / MM _____
 STABILIZER Ø / MM _____

LOW ARM C04M1+8.0
 STEER. ARM AM23-1
 WHEEL SPACER / MM _____

REAR DRIVE GB2B LOW HIGH
 DIFF. OIL _____ DIFF WASHERS _____

WHEELHUB AM06WL

SHOCKS SET

ROTOR	STD	<input type="checkbox"/>	<input type="checkbox"/>
SPRING	STD	<input type="checkbox"/>	S <input type="checkbox"/>
DAMPER	D2.2	<input type="checkbox"/>	<input type="checkbox"/>
SRS/RHS ARR.	I	<input type="checkbox"/>	II <input type="checkbox"/>
PSS SETUP	25%	<input type="checkbox"/>	15% <input type="checkbox"/>

CHASSIS FLEX AND WEIGHT SETTINGS

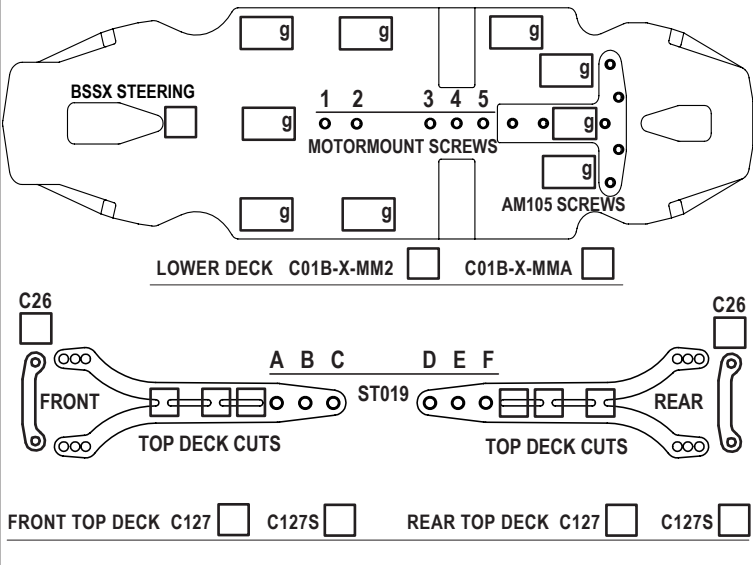

TIRES

INSERTS _____

WHEELS _____

ADDITIVE _____ TIME - FR _____ RR _____

TOTAL WEIGHT _____ WEIGHT DISTRIBUTION F % R %

NOTES: _____

MOTOR LATERAL SHIFT / MM _____	ACKERMANN POSITION _____
MOTOR _____	SERVO _____
SPUR PINION RATIO _____	STEER TRAVEL IN _____ OUT _____
BODY _____	BATTERY _____
WING _____	RECEIVER _____
ESC _____	RADIO _____
ESC SETTING _____	
BEST LAP TIME _____	QUALIF./FINAL POSITION _____ /