

NAME _____
 COUNTRY _____
 RACE _____
 TRACK _____

DATE _____ TEMP. °C AIR / TRACK _____ /
 ASPHALT OUTDOOR INDOOR CARPET
 TRACK CONDITION TECHNICAL MIXED FAST
 TRACTION LOW MEDIUM HIGH

FRONT

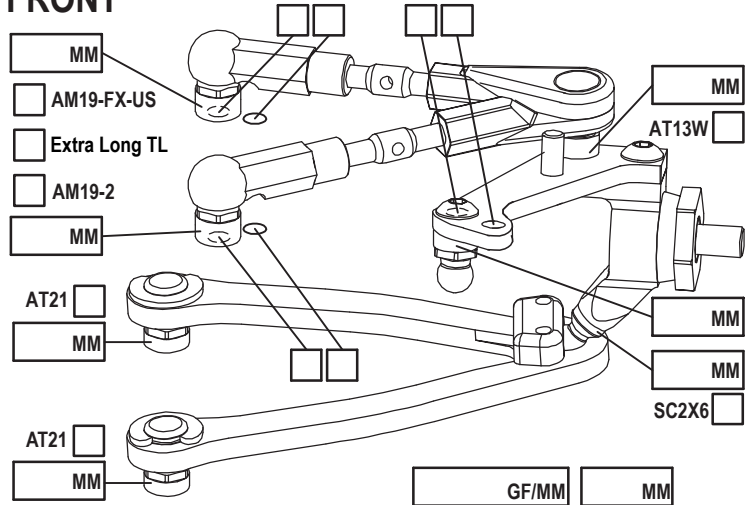

CAMBER ANGLE / ° _____
 CASTER ANGLE / ° _____
 TOE ANGLE / ° _____
 RIDE HEIGHT / MM _____
 DOWNSTOP / MM _____
 UPWNSTOP / MM _____
 STABILIZER Ø / MM _____
 LOW ARM C04M1+9.0
 STEER. ARM AM14LS
 WHEEL SPACER / MM _____
 FRONT DRIVE SPOOL GB2B LOW HIGH
 DIFF. OIL _____ DIFF WASHERS _____
 WHEELHUB AM06WL

SHOCKS SET

ROTOR	STD	<input type="checkbox"/>	<input type="checkbox"/>
SPRING	STD	<input type="checkbox"/>	S <input type="checkbox"/>
DAMPER	D2.2	<input type="checkbox"/>	<input type="checkbox"/>
SRS/RHS ARR.	I	<input type="checkbox"/>	II <input type="checkbox"/>
PSS SETUP	25%	<input type="checkbox"/>	15% <input type="checkbox"/>

REAR

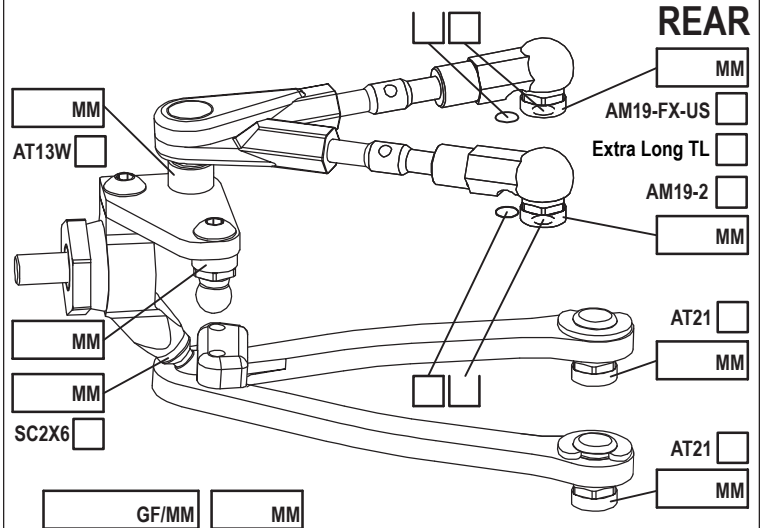

CAMBER ANGLE / ° _____
 CASTER ANGLE / ° _____
 TOE ANGLE / ° _____
 RIDE HEIGHT / MM _____
 DOWNSTOP / MM _____
 UPWNSTOP / MM _____
 STABILIZER Ø / MM _____
 LOW ARM C04M1+8.0
 STEER. ARM AM23-1
 WHEEL SPACER / MM _____
 REAR DRIVE GB2B LOW HIGH
 DIFF. OIL _____ DIFF WASHERS _____
 WHEELHUB AM06WL

SHOCKS SET

ROTOR	STD	<input type="checkbox"/>	<input type="checkbox"/>
SPRING	STD	<input type="checkbox"/>	S <input type="checkbox"/>
DAMPER	D2.2	<input type="checkbox"/>	<input type="checkbox"/>
SRS/RHS ARR.	I	<input type="checkbox"/>	II <input type="checkbox"/>
PSS SETUP	25%	<input type="checkbox"/>	15% <input type="checkbox"/>

CHASSIS FLEX AND WEIGHT SETTINGS

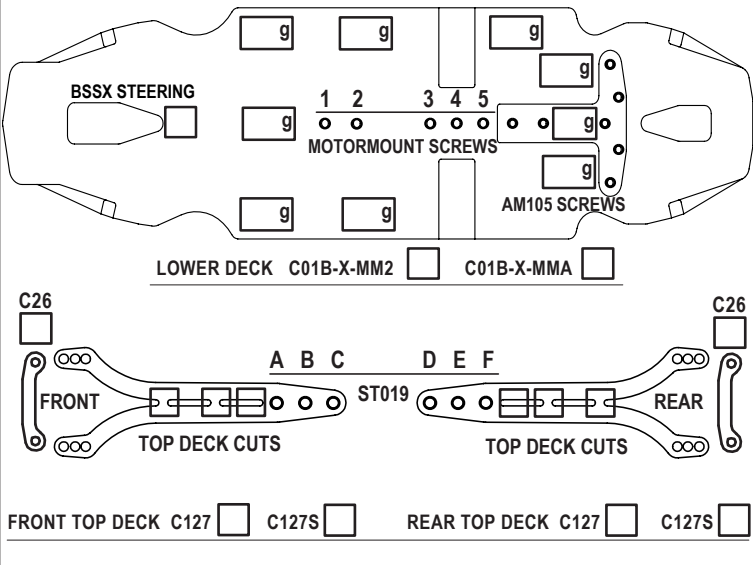

TIRES

INSERTS _____
 WHEELS _____
 ADDITIVE _____ TIME - FR _____ RR _____
 TOTAL WEIGHT _____ WEIGHT DISTRIBUTION F % R %
 NOTES: _____

MOTOR LATERAL SHIFT / MM _____ ACKERMANN POSITION _____
 MOTOR _____ SERVO _____
 SPUR PINION RATIO _____ STEER TRAVEL IN _____ OUT _____
 BODY _____ BATTERY _____
 WING _____ RECEIVER _____
 ESC _____ RADIO _____
 ESC SETTING _____
 BEST LAP TIME _____ QUALIF./FINAL POSITION _____ /