

NAME *Kemp Anderson*
 COUNTRY *USA*
 RACE *Practice*
 TRACK *Apex Raceway and Hobbies*

DATE *4-25-21* TEMP. °C AIR / TRACK *72 / 72*
 ASPHALT OUTDOOR INDOOR CARPET
 TRACK CONDITION TECHNICAL MIXED FAST
 TRACTION LOW MEDIUM HIGH

FRONT

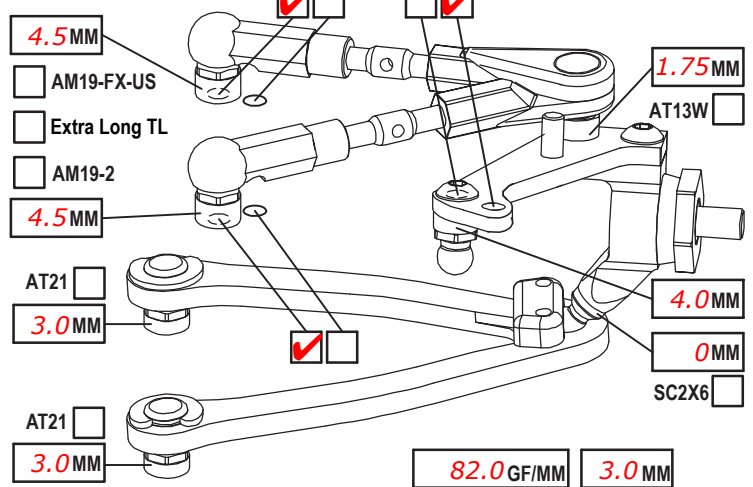

CAMBER ANGLE / °	<i>1.75</i>
CASTER ANGLE / °	<i>4</i>
TOE ANGLE / °	<i>1 out per side</i>
RIDE HEIGHT / MM	<i>5.2</i>
DOWNSTOP / MM	
UPWNSTOP / MM	<i>6.2</i>
STABILIZER Ø / MM	<i>1.0</i>
LOW ARM C04M1+9.0	<input checked="" type="checkbox"/>
STEER. ARM AM14LS	<input checked="" type="checkbox"/>
WHEEL SPACER / MM	<i>0</i>
FRONT DRIVE SPOOL	<input checked="" type="checkbox"/> GB2B <input type="checkbox"/>
DIFF. OIL	LOW <input checked="" type="checkbox"/> HIGH <input type="checkbox"/>
DIFF WASHERS	
WHEELHUB	AM06WL <input type="checkbox"/>

SHOCKS SET	
ROTOR	STD <input checked="" type="checkbox"/>
SPRING	STD <input type="checkbox"/> S <input checked="" type="checkbox"/>
DAMPER	D2.2 <input type="checkbox"/>
SRS/RHS ARR.	I <input checked="" type="checkbox"/> II <input type="checkbox"/>
PSS SETUP	25% <input type="checkbox"/> 15% <input type="checkbox"/>

REAR

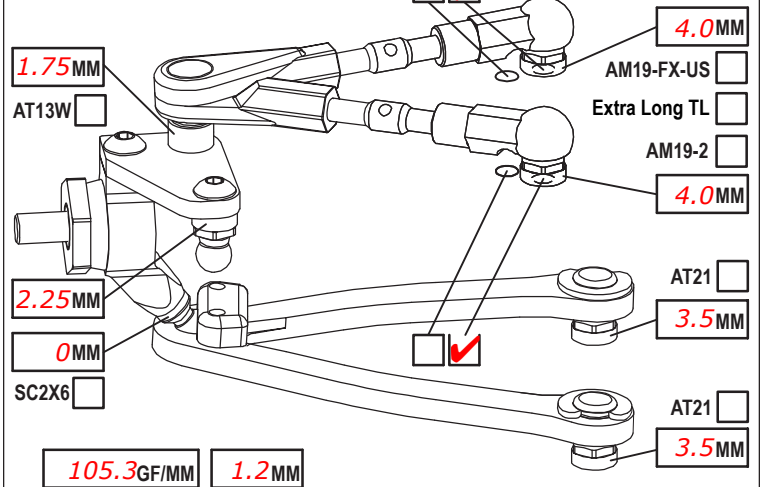

CAMBER ANGLE / °	<i>1.75</i>
CASTER ANGLE / °	<i>4 short</i>
TOE ANGLE / °	<i>3 in per side</i>
RIDE HEIGHT / MM	<i>5.4</i>
DOWNSTOP / MM	
UPWNSTOP / MM	<i>5.8</i>
STABILIZER Ø / MM	<i>1.1</i>
LOW ARM C04M1+8.0	<input checked="" type="checkbox"/>
STEER. ARM AM23-1	<input checked="" type="checkbox"/>
WHEEL SPACER / MM	<i>0</i>
REAR DRIVE	GB2B <input type="checkbox"/> LOW <input type="checkbox"/> HIGH <input checked="" type="checkbox"/>
DIFF. OIL	<i>8k</i>
DIFF WASHERS	<i>small</i>
WHEELHUB	AM06WL <input type="checkbox"/>

SHOCKS SET	
ROTOR	STD <input checked="" type="checkbox"/>
SPRING	STD <input type="checkbox"/> S <input checked="" type="checkbox"/>
DAMPER	D2.2 <input type="checkbox"/>
SRS/RHS ARR.	I <input checked="" type="checkbox"/> II <input type="checkbox"/>
PSS SETUP	25% <input type="checkbox"/> 15% <input type="checkbox"/>

CHASSIS FLEX AND WEIGHT SETTINGS

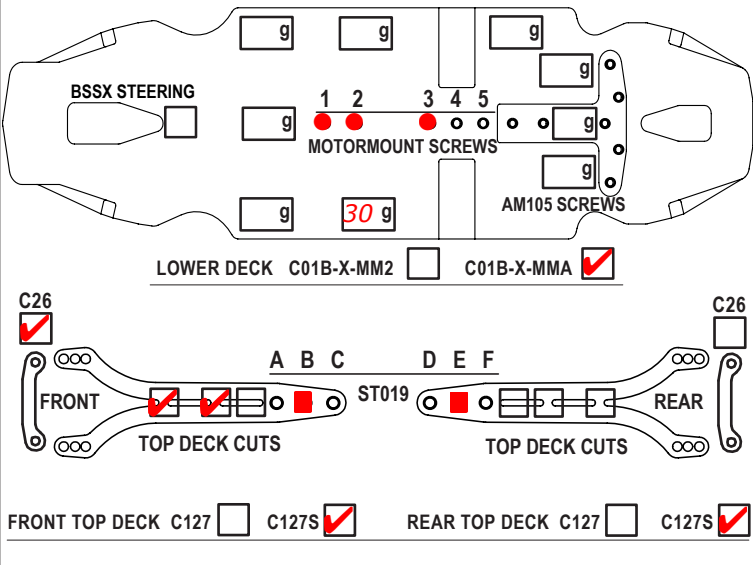

TIRES	<i>jaco</i>
INSERTS	<i>jaco</i>
WHEELS	<i>jaco</i>
ADDITIVE	<i>sxt 3.0 reg</i>
TOTAL WEIGHT	<i>1322</i>
WEIGHT DISTRIBUTION	F <i>48</i> % R <i>52</i> %
NOTES:	<i>full sauce, 58.0mm glue on the front</i>

MOTOR LATERAL SHIFT / MM	
ACKERMANN POSITION	<i>full back</i>
MOTOR	<i>Motiv MC4</i>
SERVO	<i>Sanwa</i>
SPUR PINION	<i>114</i>
RATIO	<i>27</i>
STEER TRAVEL IN	<i>27</i>
OUT	
BODY	<i>DBX .5</i>
BATTERY	<i>Team EAM 4100</i>
WING	<i>DBX .7</i>
RECEIVER	<i>Sanwa</i>
ESC	<i>Hobbywing</i>
RADIO	<i>Sanwa</i>
ESC SETTING	<i>boosted</i>
BEST LAP TIME	
QUALIF./FINAL POSITION	<i>/</i>

Arrowmax oils used in diff and dampener