

NAME _____
 COUNTRY _____
 RACE _____
 TRACK _____

DATE _____ TEMP. °C AIR / TRACK _____ /
 ASPHALT OUTDOOR INDOOR CARPET
 TRACK CONDITION TECHNICAL MIXED FAST
 TRACTION LOW MEDIUM HIGH

FRONT

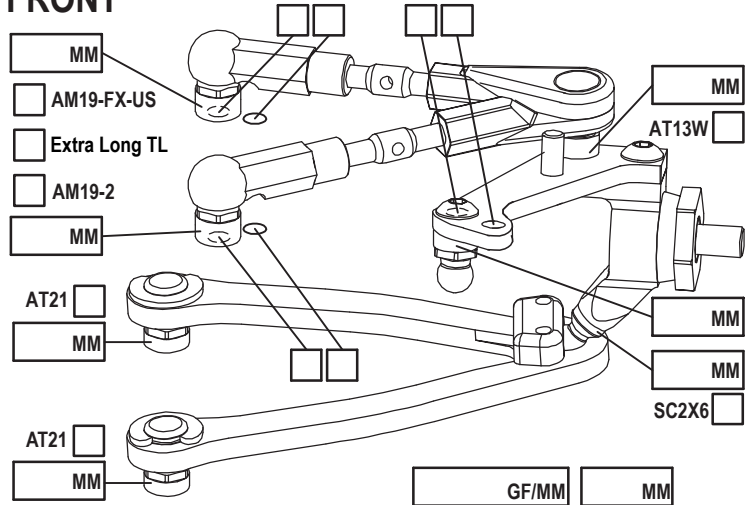

CAMBER ANGLE / ° _____
 CASTER ANGLE / ° _____
 TOE ANGLE / ° _____
 RIDE HEIGHT / MM _____
 DOWNSTOP / MM _____
 UPWNSTOP / MM _____
 STABILIZER Ø / MM _____
 ROTOR STD S
 SPRING STD S
 DAMPER D2.2
 SRS/RHS ARR. I II
 PSS SETUP 25% 15%
 LOW ARM C04M1+9.0
 STEER. ARM AM14LS
 WHEEL SPACER / MM _____
 FRONT DRIVE SPOOL GB2B LOW HIGH
 DIFF. OIL _____ DIFF WASHERS _____
 WHEELHUB AM06WL

REAR

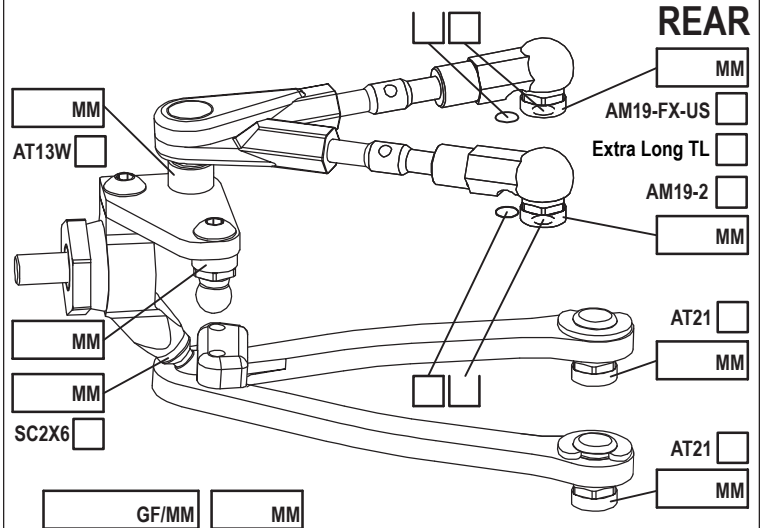

CAMBER ANGLE / ° _____
 CASTER ANGLE / ° _____
 TOE ANGLE / ° _____
 RIDE HEIGHT / MM _____
 DOWNSTOP / MM _____
 UPWNSTOP / MM _____
 STABILIZER Ø / MM _____
 ROTOR STD S
 SPRING STD S
 DAMPER D2.2
 SRS/RHS ARR. I II
 PSS SETUP 25% 15%
 LOW ARM C04M1+8.0
 STEER. ARM AM23-1
 WHEEL SPACER / MM _____
 REAR DRIVE GB2B LOW HIGH
 DIFF. OIL _____ DIFF WASHERS _____
 WHEELHUB AM06WL

CHASSIS FLEX AND WEIGHT SETTINGS

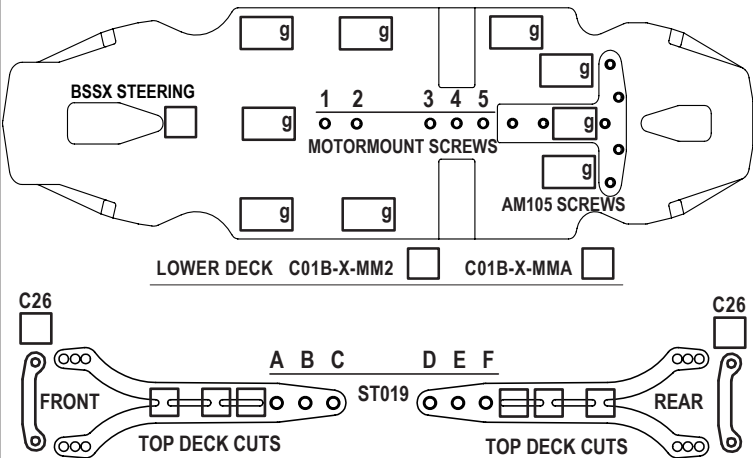

FRONT TOP DECK C127 C127S REAR TOP DECK C127 C127S

TIRES

INSERTS _____
 WHEELS _____
 ADDITIVE _____ TIME - FR _____ RR _____
 TOTAL WEIGHT _____ WEIGHT DISTRIBUTION F % R %
 NOTES: _____

MOTOR LATERAL SHIFT / MM _____ ACKERMANN POSITION _____
 MOTOR _____ SERVO _____
 SPUR PINION RATIO _____ STEER TRAVEL IN _____ OUT _____
 BODY _____ BATTERY _____
 WING _____ RECEIVER _____
 ESC _____ RADIO _____
 ESC SETTING _____
 BEST LAP TIME _____ QUALIF./FINAL POSITION _____ /