

NAME \_\_\_\_\_  
 COUNTRY \_\_\_\_\_  
 RACE \_\_\_\_\_  
 TRACK \_\_\_\_\_

DATE \_\_\_\_\_ TEMP.°C AIR / TRACK \_\_\_\_\_ /  
 CARPET  ASPHALT   
 TRACK CONDITION TECHNICAL  MIXED  FAST   
 TRACTION LOW  MEDIUM  HIGH

### FRONT

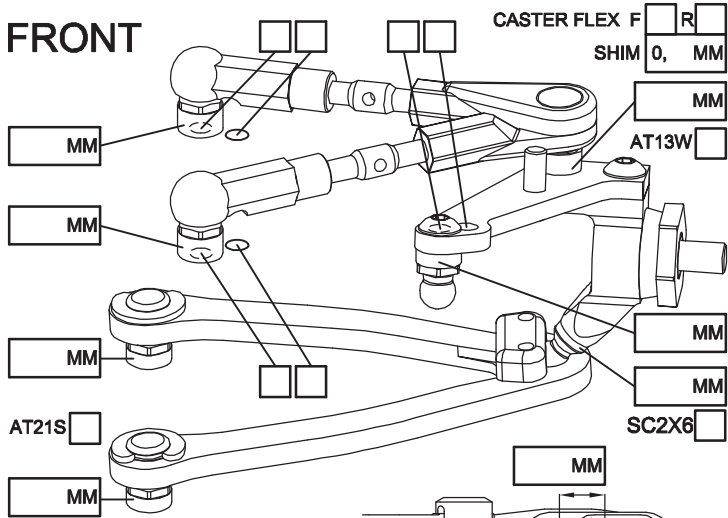

CAMBER ANGLE / ° \_\_\_\_\_  
 CASTER ANGLE / ° \_\_\_\_\_  
 TOE ANGLE / ° \_\_\_\_\_  
 RIDE HEIGHT / MM \_\_\_\_\_  
 DOWNSTOP / MM \_\_\_\_\_  
 UPSTOP / MM \_\_\_\_\_  
 STABILIZER Ø / MM \_\_\_\_\_  
 LOW ARM C04AL    
 STEERING ARM STD    
 WHEEL SPACER / MM \_\_\_\_\_  
 FRONT DRIVE  GD3  SPOOL  GD2B

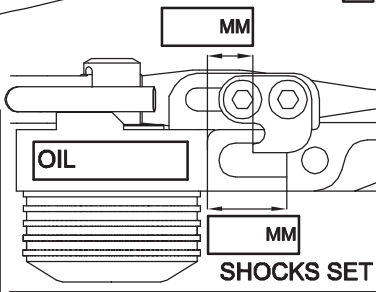

SHOCKS SET  
 ROTOR STD    
 SPRING STD  S   
 DAMPER D2.1    
 ACTION SYM.  ASYM.   
 SRS/RHS ARR. I  II

DIFF OIL \_\_\_\_\_ DIFF WASHERS \_\_\_\_\_  
 DOGBONE DRIVE ST17-1  ST11  ST12  BB  ST02

### REAR

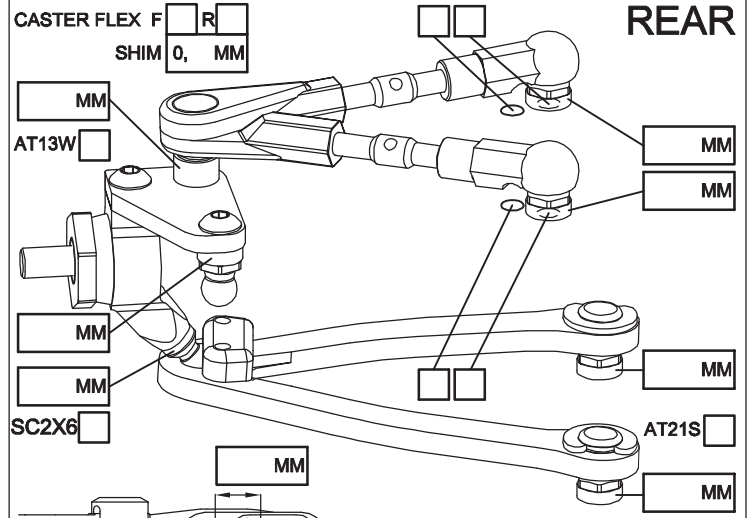

CAMBER ANGLE / ° \_\_\_\_\_  
 CASTER ANGLE / ° \_\_\_\_\_  
 TOE ANGLE / ° \_\_\_\_\_  
 RIDE HEIGHT / MM \_\_\_\_\_  
 DOWNSTOP / MM \_\_\_\_\_  
 UPSTOP / MM \_\_\_\_\_  
 STABILIZER Ø / MM \_\_\_\_\_  
 LOW ARM C04AL    
 STEERING ARM STD    
 WHEEL SPACER / MM \_\_\_\_\_  
 REAR DRIVE  GD3R  GD2B

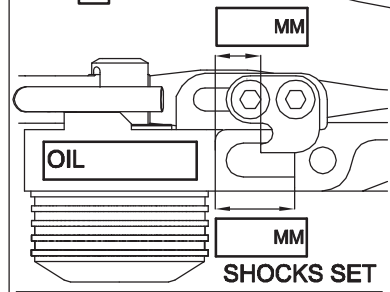

SHOCKS SET  
 ROTOR STD    
 SPRING STD  S   
 DAMPER D2.1    
 ACTION SYM.  ASYM.   
 SRS/RHS ARR. I  II

DIFF OIL \_\_\_\_\_ DIFF WASHERS \_\_\_\_\_  
 DOGBONE DRIVE ST11  ST12  BB  ST17-1  EVD

### FRAME FLEX SETTING

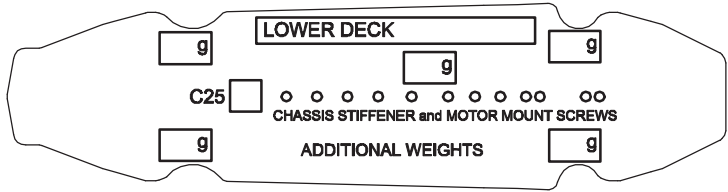

CHASSIS STIFFENER AM110  AM115  ST130

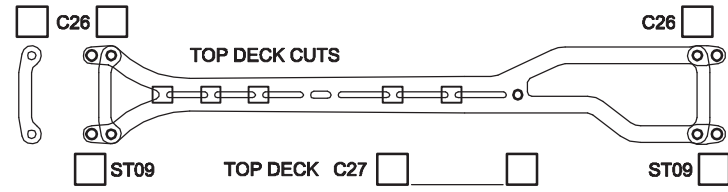

COMMENTS

FL	FR	RL	RR	TIRES	FRONT	REAR
				BRAND		
				INSERTS		
				WHEELS		
				ADDITIVE		

MOTOR LATERAL SHIFT / MM \_\_\_\_\_ MOTOR \_\_\_\_\_  
 ACKERMANN SHIMS / MM \_\_\_\_\_ SERVO \_\_\_\_\_  
 DRIVE RATIO \_\_\_\_\_ ESC \_\_\_\_\_  
 SPUR PINION \_\_\_\_\_ BATTERY \_\_\_\_\_  
 BODY \_\_\_\_\_ RECEIVER \_\_\_\_\_  
 WING \_\_\_\_\_

BEST LAPTIME \_\_\_\_\_ QUALIF. / FINAL POSITION \_\_\_\_\_ /

ESC SETTING \_\_\_\_\_  
 COMMENTS / IMPRESSIONS \_\_\_\_\_  
 CONTACT \_\_\_\_\_