

NAME _____

COUNTRY _____

RACE _____

TRACK _____

DATE _____ TEMP.°C AIR / TRACK _____ / _____

TRACK CONDITION TECHNICAL CARPET ASPHALT

MIXED FAST

TRACTION LOW MEDIUM HIGH

FRONT

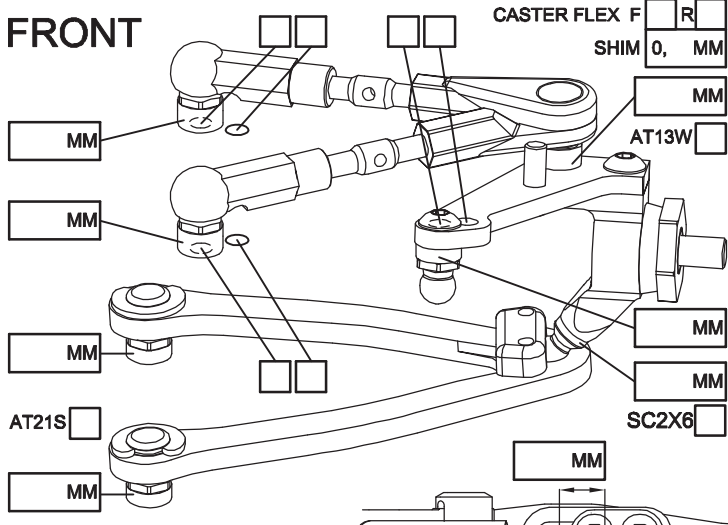

CAMBER ANGLE / ° _____

CASTER ANGLE / ° _____

TOE ANGLE / ° _____

RIDE HEIGHT / MM _____

DOWNSTOP / MM _____

UPSTOP / MM _____

STABILIZER Ø / MM _____

LOW ARM C04AL

STEERING ARM STD

WHEEL SPACER / MM _____

FRONT DRIVE GD3 SPOOL GD2B

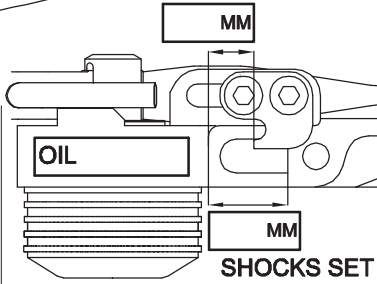

SHOCKS SET

ROTOR STD

SPRING STD S

DAMPER D2.1

ACTION SYM. ASYM.

SRS/RHS ARR. I II

DIFF OIL _____ DIFF WASHERS _____

DOGBONE DRIVE ST17-1 ST11 ST12 BB ST02

REAR

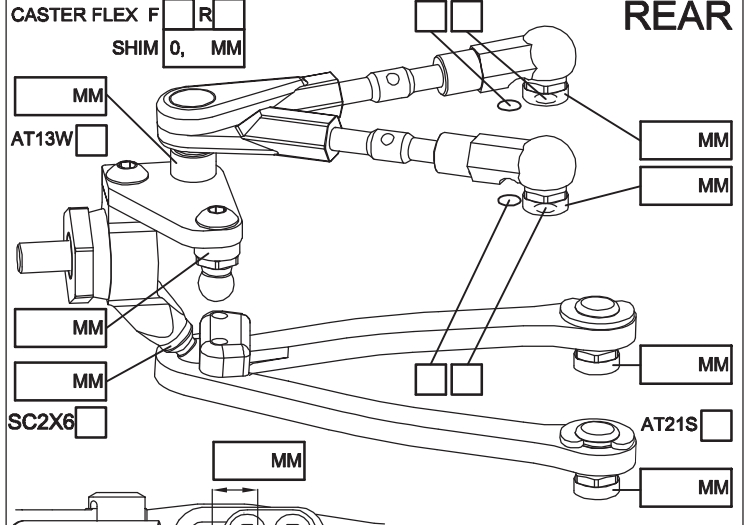

CAMBER ANGLE / ° _____

CASTER ANGLE / ° _____

TOE ANGLE / ° _____

RIDE HEIGHT / MM _____

DOWNSTOP / MM _____

UPSTOP / MM _____

STABILIZER Ø / MM _____

LOW ARM C04AL

STEERING ARM STD

WHEEL SPACER / MM _____

REAR DRIVE GD3R GD2B

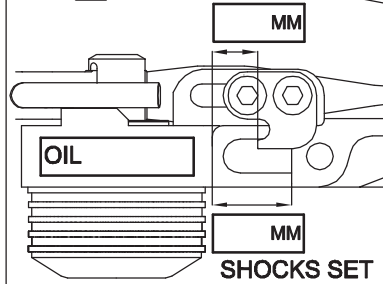

SHOCKS SET

ROTOR STD

SPRING STD S

DAMPER D2.1

ACTION SYM. ASYM.

SRS/RHS ARR. I II

DIFF OIL _____ DIFF WASHERS _____

DOGBONE DRIVE ST11 ST12 BB ST17-1 EVD

FRAME FLEX SETTING

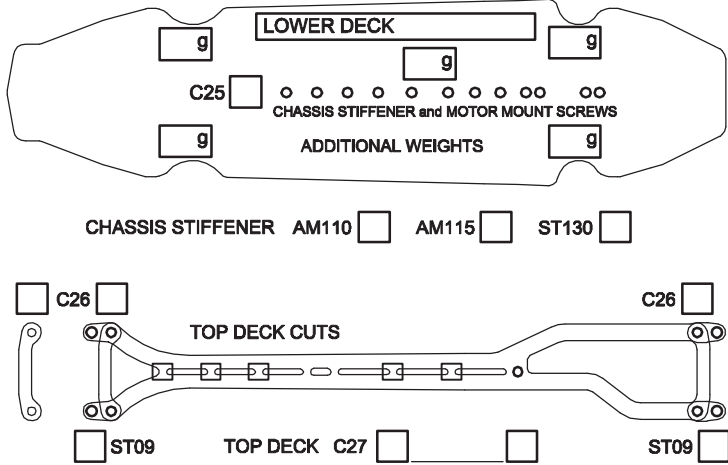

COMMENTS

FL	FR	RL	RR	TIRES	FRONT	REAR
				BRAND		
				INSERTS		
				WHEELS		
				ADDITIVE		

MOTOR LATERAL SHIFT / MM	MOTOR
ACKERMANN SHIMS / MM	SERVO
DRIVE RATIO	ESC
SPUR PINION	BATTERY
BODY	RECEIVER
WING	

BEST LAP TIME _____ QUALIF. / FINAL POSITION _____ / _____

ESC SETTING _____

COMMENTS / IMPRESSIONS _____

CONTACT