

NAME _____
 COUNTRY _____
 RACE _____
 TRACK _____

DATE _____ TEMP.°C AIR / TRACK _____ /
 TRACK CONDITION TECHNICAL CARPET ASPHALT
 MIXED FAST
 TRACTION LOW MEDIUM HIGH

FRONT

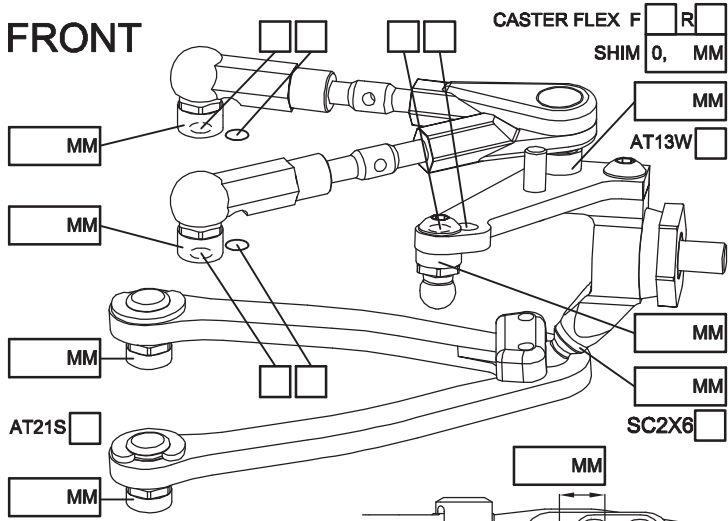

CAMBER ANGLE / ° _____
 CASTER ANGLE / ° _____
 TOE ANGLE / ° _____
 RIDE HEIGHT / MM _____
 DOWNSTOP / MM _____
 UPSTOP / MM _____
 STABILIZER Ø / MM _____
 LOW ARM C04AL
 STEERING ARM STD
 WHEEL SPACER / MM _____
 FRONT DRIVE GD3 SPOOL GD2B

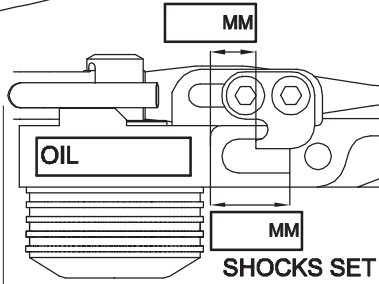

SHOCKS SET

ROTOR	STD	<input type="checkbox"/>	<input type="checkbox"/>
SPRING	STD	<input type="checkbox"/>	S <input type="checkbox"/>
DAMPER	D2.1	<input type="checkbox"/>	<input type="checkbox"/>
ACTION	SYM.	<input type="checkbox"/>	ASYM. <input type="checkbox"/>
SRS/RHS ARR.	I	<input type="checkbox"/>	II <input type="checkbox"/>

DIFF OIL _____ DIFF WASHERS _____
 DOGBONE DRIVE ST17-1 ST11 ST12 BB ST02

REAR

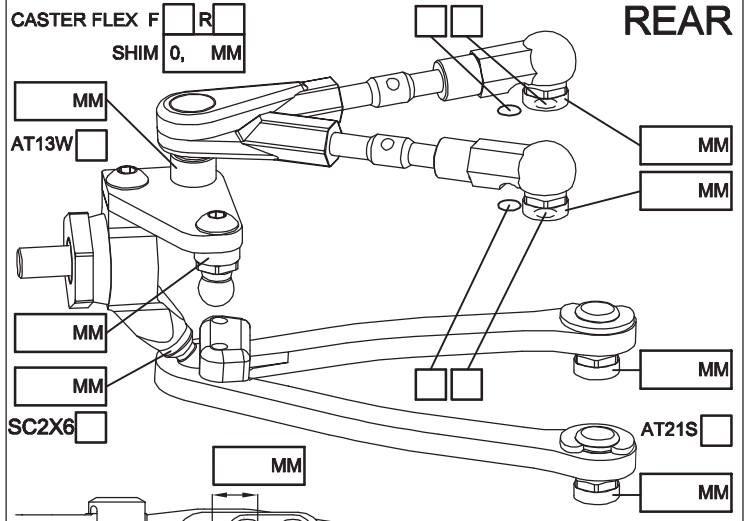

CAMBER ANGLE / ° _____
 CASTER ANGLE / ° _____
 TOE ANGLE / ° _____
 RIDE HEIGHT / MM _____
 DOWNSTOP / MM _____
 UPSTOP / MM _____
 STABILIZER Ø / MM _____
 LOW ARM C04AL
 STEERING ARM STD
 WHEEL SPACER / MM _____
 REAR DRIVE GD3R GD2B

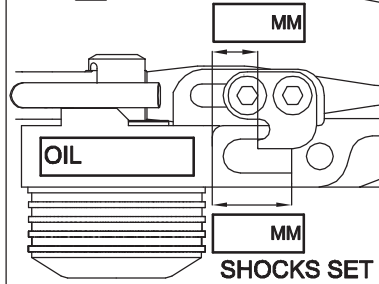

SHOCKS SET

ROTOR	STD	<input type="checkbox"/>	<input type="checkbox"/>
SPRING	STD	<input type="checkbox"/>	S <input type="checkbox"/>
DAMPER	D2.1	<input type="checkbox"/>	<input type="checkbox"/>
ACTION	SYM.	<input type="checkbox"/>	ASYM. <input type="checkbox"/>
SRS/RHS ARR.	I	<input type="checkbox"/>	II <input type="checkbox"/>

DIFF OIL _____ DIFF WASHERS _____
 DOGBONE DRIVE ST11 ST12 BB ST17-1 EVD

FRAME FLEX SETTING

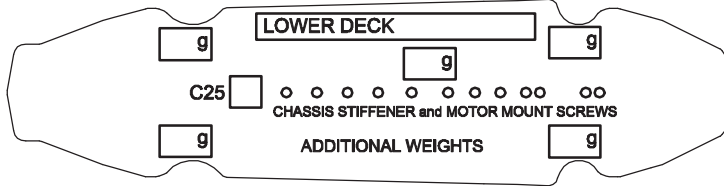

CHASSIS STIFFENER AM110 AM115 ST130

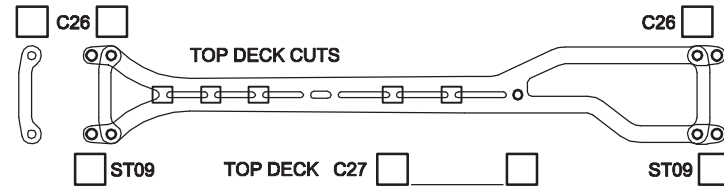

COMMENTS _____

FL	FR	RL	RR	TIRES	FRONT	REAR
				BRAND		
				INSERTS		
				WHEELS		
				ADDITIVE		

MOTOR LATERAL SHIFT / MM _____	MOTOR _____
ACKERMANN SHIMS / MM _____	SERVO _____
DRIVE RATIO _____	ESC _____
SPUR _____ PINION _____	BATTERY _____
BODY _____	RECEIVER _____
WING _____	

BEST LAP TIME _____ QUALIF. / FINAL POSITION _____ /
 ESC SETTING _____

COMMENTS / IMPRESSIONS _____

CONTACT _____