

NAME _____
 COUNTRY _____
 RACE _____
 TRACK _____

DATE _____ TEMP.°C AIR / TRACK _____ /
 CARPET ASPHALT
 TRACK CONDITION TECHNICAL MIXED FAST
 TRACTION LOW MEDIUM HIGH

FRONT

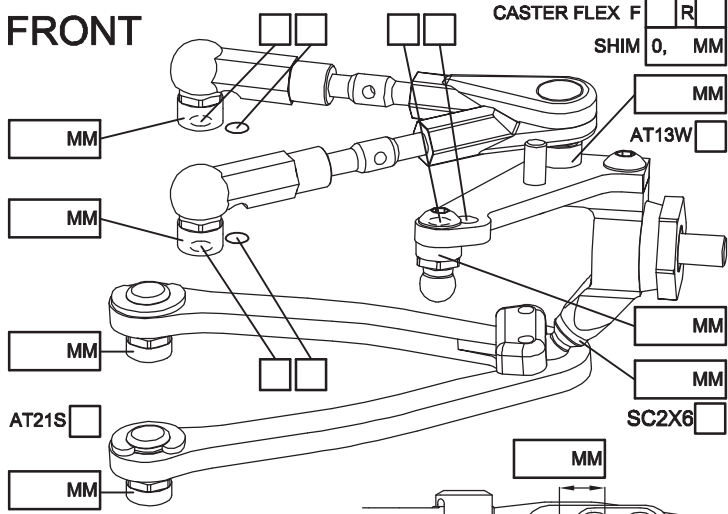

CAMBER ANGLE / ° _____
 CASTER ANGLE / ° _____
 TOE ANGLE / ° _____
 RIDE HEIGHT / MM _____
 DOWNSTOP / MM _____
 UPSTOP / MM _____
 STABILIZER Ø / MM _____
 LOW ARM C04AL
 STEERING ARM STD
 WHEEL SPACER / MM _____
 FRONT DRIVE GD3 SPOOL GD2B

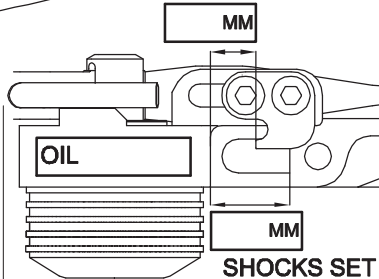

SHOCKS SET
 ROTOR STD
 SPRING STD S
 DAMPER D2.1
 ACTION SYM. ASYM.
 SRS/RHS ARR. I II

DIFF OIL _____ DIFF WASHERS _____
 DOGBONE DRIVE ST17-1 ST11 ST12 BB ST02

REAR

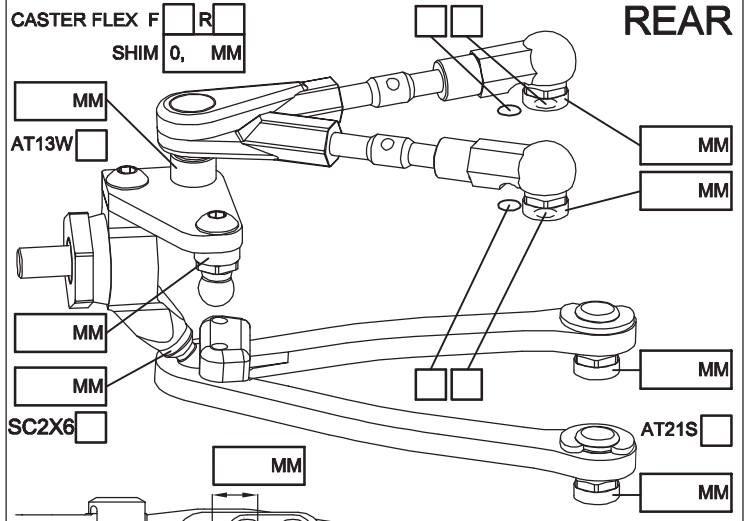

CAMBER ANGLE / ° _____
 CASTER ANGLE / ° _____
 TOE ANGLE / ° _____
 RIDE HEIGHT / MM _____
 DOWNSTOP / MM _____
 UPSTOP / MM _____
 STABILIZER Ø / MM _____
 LOW ARM C04AL
 STEERING ARM STD
 WHEEL SPACER / MM _____
 REAR DRIVE GD3R GD2B

DIFF OIL _____ DIFF WASHERS _____
 DOGBONE DRIVE ST11 ST12 BB ST17-1 EVD

FRAME FLEX SETTING

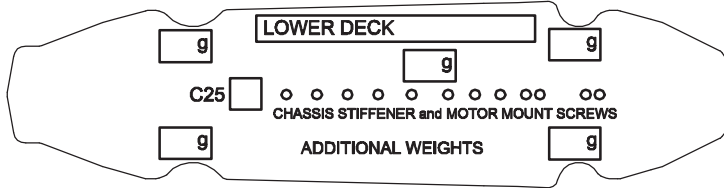

CHASSIS STIFFENER AM110 AM115 ST130

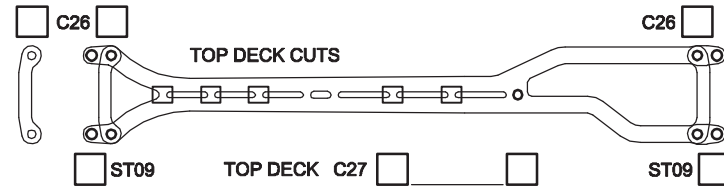

COMMENTS _____

FL	FR	RL	RR	TIRES	FRONT	REAR
				BRAND	_____	_____
				INSERTS	_____	_____
				WHEELS	_____	_____
				ADDITIVE	_____	_____

MOTOR LATERAL SHIFT / MM _____ MOTOR _____
 ACKERMANN SHIMS / MM _____ SERVO _____
 DRIVE RATIO _____ ESC _____
 SPUR PINION _____ BATTERY _____
 BODY _____ RECEIVER _____
 WING _____

BEST LAPTIME _____ QUALIF. / FINAL POSITION _____ /

ESC SETTING _____
 COMMENTS / IMPRESSIONS _____

CONTACT _____