

NAME _____
 COUNTRY _____
 RACE _____
 TRACK _____

DATE _____ TEMP. °C AIR / TRACK _____ /
 ASPHALT (OUTDOOR INDOOR) CARPET
 TRACK CONDITION TECHNICAL MIXED FAST
 TRACTION LOW MEDIUM HIGH

FRONT

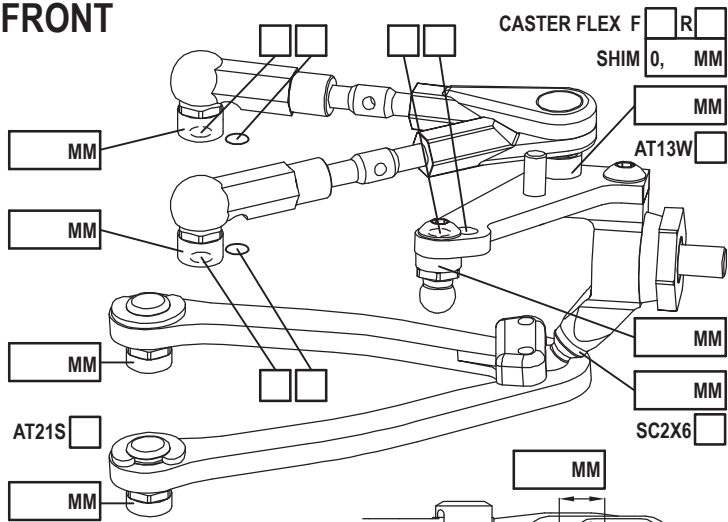

CAMBER ANGLE / ° _____
 CASTER ANGLE / ° _____
 TOE ANGLE / ° _____
 RIDE HEIGHT / MM _____
 DOWNSTOP / MM _____
 UPWNSTOP / MM _____
 STABILIZER Ø / MM _____
 LOW ARM C04AL _____
 STEERING ARM STD _____
 WHEEL SPACER / MM _____
 FRONT DRIVE GD3 SPOOL GB2B LOW HIGH
 DIFF. OIL _____ DIFF WASHERS _____
 DOGBONE DRIVE ST17-1 ST11 ST12 BB ST02
 WHEELHUB AM06M AM06S-M AM06W

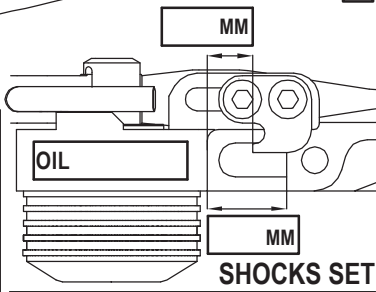

ROTOR STD _____
 SPRING STD S
 DAMPER D2.1 _____
 ACTION SYM. ASYM.
 SRS/RHS ARR. I II

REAR

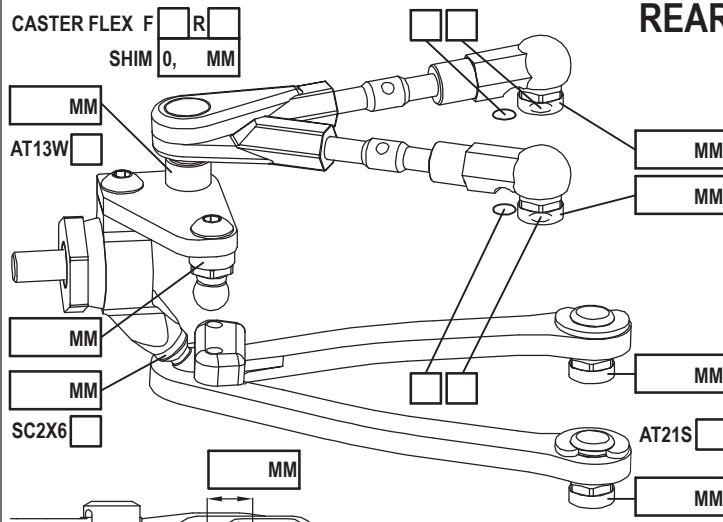

CAMBER ANGLE / ° _____
 CASTER ANGLE / ° _____
 TOE ANGLE / ° _____
 RIDE HEIGHT / MM _____
 DOWNSTOP / MM _____
 UPWNSTOP / MM _____
 STABILIZER Ø / MM _____
 LOW ARM C04AL _____
 STEERING ARM STD _____
 WHEEL SPACER / MM _____
 REAR DRIVE GD3R GB2B LOW HIGH
 DIFF. OIL _____ DIFF WASHERS _____
 DOGBONE DRIVE ST11 ST12 BB ST17-1 EVD
 WHEELHUB AM06M AM06S-M AM06W

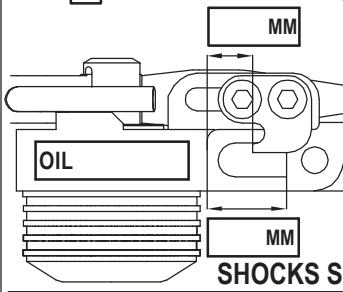

ROTOR STD _____
 SPRING STD S
 DAMPER D2.1 _____
 ACTION SYM. ASYM.
 SRS/RHS ARR. I II

FRAME FLEX SETTING

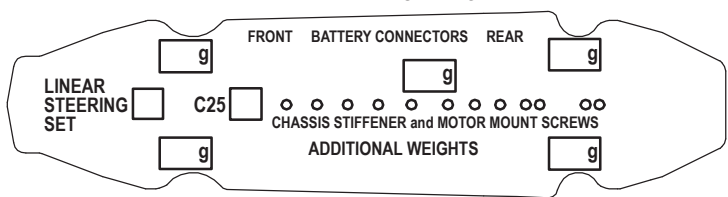

LOWER DECK

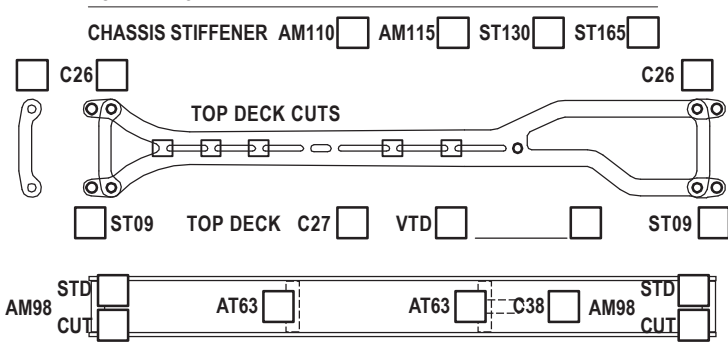

TIRES FRONT FL FR REAR RL RR
 BRAND _____
 INSERTS _____
 WHEELS _____
 ADDITIVE _____

MOTOR LATERAL SHIFT / MM _____
 MOTOR _____
 SPUR PINION RATIO _____
 BODY _____
 WING _____
 ESC _____
 ESC SETTING _____
 BEST LAPTIME _____ QUALIF./FINAL POSITION _____ /
 CONTACT _____

ACKERMANN SHIMS / MM _____
 SERVO _____
 STEER TRAVEL IN _____ OUT _____
 BATTERY _____
 RECEIVER _____
 RADIO _____