

NAME *Viljami Kutvonen*  
COUNTRY *Finland*  
RACE *ETS Round 1*  
TRACK *Wien, Austria*

DATE *29.10.2017* TEMP. °C AIR / TRACK °C / °C  
 ASPHALT  (OUTDOOR  INDOOR  ) CARPET   
 TRACK CONDITION TECHNICAL  MIXED  FAST   
 TRACTION LOW  MEDIUM  HIGH

## FRONT

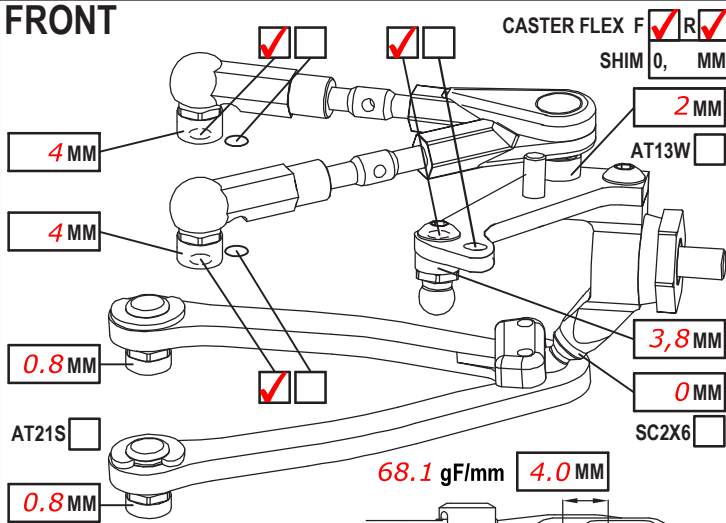

CAMBER ANGLE / °	<i>2</i>
CASTER ANGLE / °	<i>4</i>
TOE ANGLE / °	<i>1,25</i>
RIDE HEIGHT / MM	<i>5</i>
DOWNSTOP / MM	<i>6</i>
UPWNSTOP / MM	
STABILIZER Ø / MM	<i>1,1</i>
LOW ARM C04M1	<input type="checkbox"/> <i>+0,5</i> <input checked="" type="checkbox"/>
STEER. ARM AM14A	<input type="checkbox"/> <i>LS</i> <input checked="" type="checkbox"/>
WHEEL SPACER / MM	
FRONT DRIVE GD3	<input type="checkbox"/> SPOOL <input checked="" type="checkbox"/> GB2B <input type="checkbox"/> LOW <input checked="" type="checkbox"/> HIGH <input type="checkbox"/>
DIFF. OIL	DIFF WASHERS
DOGBONE DRIVE ST17	<input type="checkbox"/> ST11 <input type="checkbox"/> ST12 <input type="checkbox"/> BB <input checked="" type="checkbox"/> ST02 <input type="checkbox"/>
WHEELHUB AM06WL	<input checked="" type="checkbox"/> AM06S-M <input type="checkbox"/> AM06W <input type="checkbox"/>

SHOCKS SET	
ROTOR STD	<input checked="" type="checkbox"/>
SPRING STD	<input type="checkbox"/> S <input checked="" type="checkbox"/>
DAMPER D2.2	<input checked="" type="checkbox"/>
ACTION SYM.	<input type="checkbox"/> ASYM. <input type="checkbox"/>
SRS/RHS ARR. I	<input checked="" type="checkbox"/> II <input type="checkbox"/>

## REAR

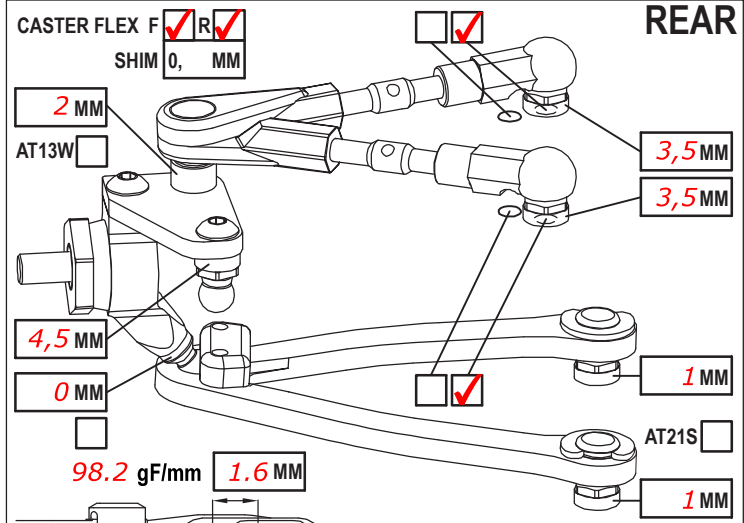

CAMBER ANGLE / °	<i>2</i>
CASTER ANGLE / °	<i>0</i>
TOE ANGLE / °	<i>3,25</i>
RIDE HEIGHT / MM	<i>5,2</i>
DOWNSTOP / MM	<i>5</i>
UPWNSTOP / MM	
STABILIZER Ø / MM	<i>1,0</i>
LOW ARM C04M1	<input checked="" type="checkbox"/>
STEER. ARM AM23	<input checked="" type="checkbox"/>
WHEEL SPACER / MM	
REAR DRIVE GD3R	<input type="checkbox"/> GB2B <input checked="" type="checkbox"/> LOW <input checked="" type="checkbox"/> HIGH <input type="checkbox"/>
DIFF. OIL <i>10k</i>	DIFF WASHERS
DOGBONE DRIVE ST11	<input type="checkbox"/> ST12 <input type="checkbox"/> BB <input checked="" type="checkbox"/> ST17 <input type="checkbox"/> EVD <input type="checkbox"/>
WHEELHUB AM06WL	<input type="checkbox"/> AM06S-M <input checked="" type="checkbox"/> AM06W <input type="checkbox"/>

SHOCKS SET	
ROTOR STD	<input type="checkbox"/> S <input checked="" type="checkbox"/>
SPRING STD	<input type="checkbox"/> S <input checked="" type="checkbox"/>
DAMPER D2.2	<input checked="" type="checkbox"/>
ACTION SYM.	<input type="checkbox"/> ASYM. <input type="checkbox"/>
SRS/RHS ARR. I	<input checked="" type="checkbox"/> II <input type="checkbox"/>

## FRAME FLEX SETTING

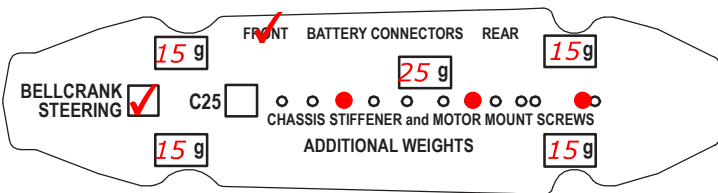

LOWER DECK *Std carbon*

CHASSIS STIFFENER AM110  AM115  ST130  ST165

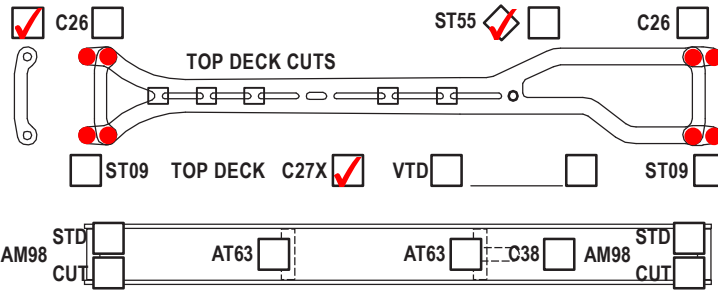

FL	FR	RL	RR	TIRES	FRONT	REAR
				BRAND	<i>Volante 28</i>	
				INSERTS	<i>ETS</i>	
				WHEELS	<i>ETS</i>	
				ADDITIVE	<i>Handout</i>	

MOTOR LATERAL SHIFT / MM	ACKERMANN SHIMS / MM <i>0</i>
MOTOR <i>LRP X22 5.0T</i>	SERVO <i>Highest DLP650</i>
SPUR116 PINION <i>28</i> RATIO <i>7.87</i>	STEER TRAVEL IN <i>27</i> OUT
BODY <i>Montech Racer</i>	BATTERY <i>LRP 5500 Ultra LCG</i>
WING <i>Standard</i>	RECEIVER <i>Sanwa</i>
ESC <i>LRP Flow X</i>	RADIO <i>Sanwa</i>
ESC SETTING	
BEST LAPTIME	QUALIF./FINAL POSITION <i>/</i>
CONTACT	

COMMENTS  
*65g stiffener in center, 25g glued inside side of battery  
IFJ in front*