

NAME *Viljami Kutvonen*
 COUNTRY *Finland*
 RACE *ETS Rd 6 2014*
 TRACK *Hudy Arena, Trencin*

DATE *06.07.2014* TEMP.°C AIR / TRACK *25°C / °C*
 TRACK CONDITION TECHNICAL MIXED FAST
 TRACTION LOW MEDIUM HIGH

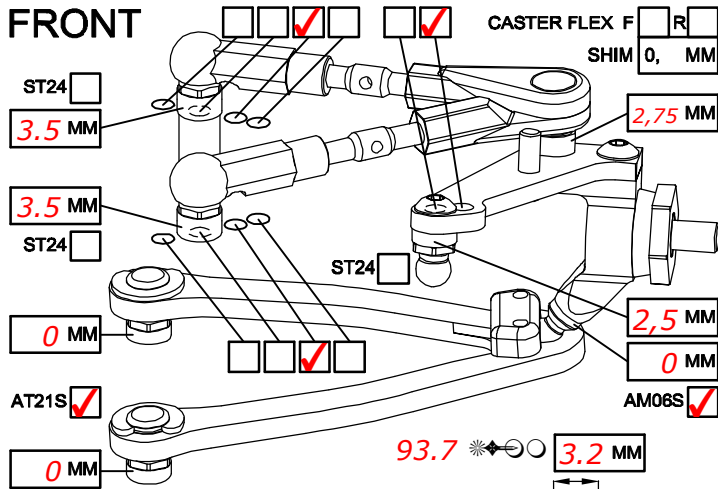

CAMBER ANGLE / °	<i>2</i>
CASTER ANGLE / °	<i>4</i>
TOE ANGLE / °	<i>0,25 out</i>
RIDE HEIGHT / MM	<i>5.2</i>
DOWNSTOP / MM	<i>7</i>
UPSTOP / MM	<i>max</i>
STABILIZER Ø / MM	<i>1.1</i>
LOW ARM STD	<input checked="" type="checkbox"/>
STEERING ARM STD	<input checked="" type="checkbox"/>
WHEEL SPACER / MM	<i>0</i>
FRONT DRIVE BALL DIFF	<input type="checkbox"/>
FRONT DRIVE GEAR DIFF	<input type="checkbox"/>
FRONT DRIVE SPOOL	<input checked="" type="checkbox"/>
FRONT DRIVE ONE-WAY	<input type="checkbox"/>
DIFF SET LOOSE	<input type="checkbox"/>
DIFF SET MEDIUM	<input type="checkbox"/>
DIFF SET TIGHT	<input type="checkbox"/>
DIFF SET OIL	<input type="checkbox"/>
DIFF SET #	
DOGBONE DRIVE BUSHING	<input checked="" type="checkbox"/>
DOGBONE DRIVE C-DRIVE	<input type="checkbox"/>
DOGBONE DRIVE BB	<input type="checkbox"/>
DOGBONE DRIVE EVD	<input checked="" type="checkbox"/>

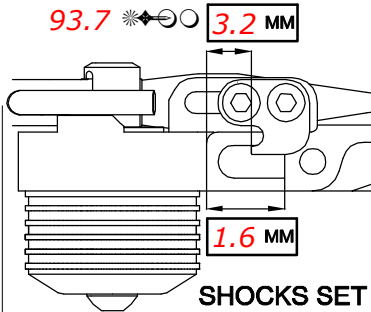

SHOCKS SET			
SPRING STD	<input checked="" type="checkbox"/>	S	<input type="checkbox"/>
DAMPER #6	<input checked="" type="checkbox"/>	#3	<input type="checkbox"/>
ACTION SYM.	<input checked="" type="checkbox"/>	ASYM.	<input type="checkbox"/>
SRS/RHS ARR. I	<input checked="" type="checkbox"/>	II	<input type="checkbox"/>

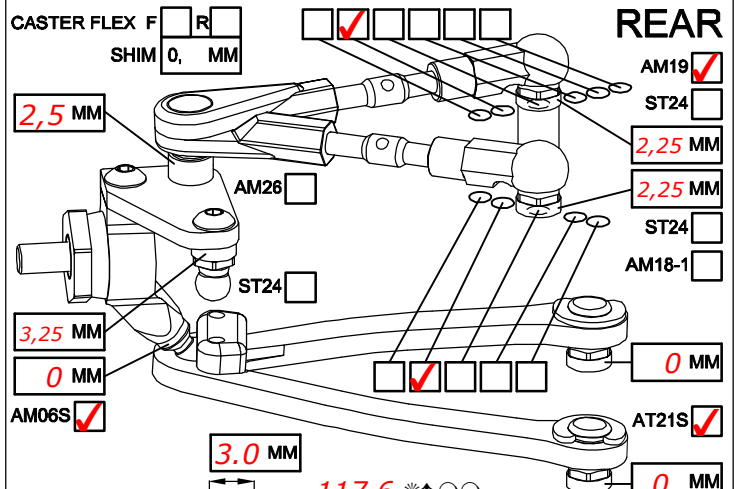

CAMBER ANGLE / °	<i>2</i>
CASTER ANGLE / °	<i>4 forward</i>
TOE ANGLE / °	<i>1,5</i>
RIDE HEIGHT / MM	<i>5.4</i>
DOWNSTOP / MM	<i>5,8</i>
UPSTOP / MM	<i>max</i>
STABILIZER Ø / MM	<i>1.0</i>
LOW ARM STD	<input checked="" type="checkbox"/>
STEERING ARM STD	<input checked="" type="checkbox"/>
WHEEL SPACER / MM	<i>0</i>
REAR DRIVE BALL DIFF	<input type="checkbox"/>
REAR DRIVE GEAR DIFF	<input checked="" type="checkbox"/>
DIFF SET LOOSE	<input type="checkbox"/>
DIFF SET MEDIUM	<input type="checkbox"/>
DIFF SET TIGHT	<input type="checkbox"/>
DIFF SET OIL	<input checked="" type="checkbox"/>
DIFF SET #	<i>5000</i>
DOGBONE DRIVE BUSHING	<input type="checkbox"/>
DOGBONE DRIVE C-DRIVE	<input type="checkbox"/>
DOGBONE DRIVE BB	<input checked="" type="checkbox"/>
DOGBONE DRIVE EVD	<input type="checkbox"/>

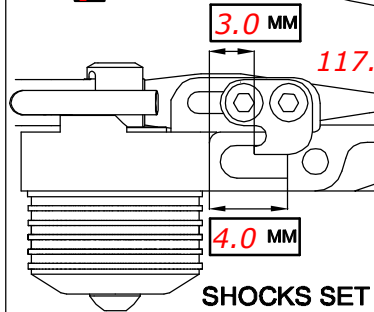

SHOCKS SET			
SPRING STD	<input checked="" type="checkbox"/>	S	<input type="checkbox"/>
DAMPER #6	<input checked="" type="checkbox"/>	#3	<input type="checkbox"/>
ACTION SYM.	<input checked="" type="checkbox"/>	ASYM.	<input type="checkbox"/>
SRS/RHS ARR. I	<input checked="" type="checkbox"/>	II	<input type="checkbox"/>

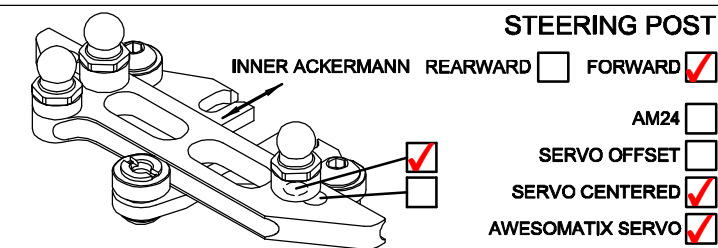
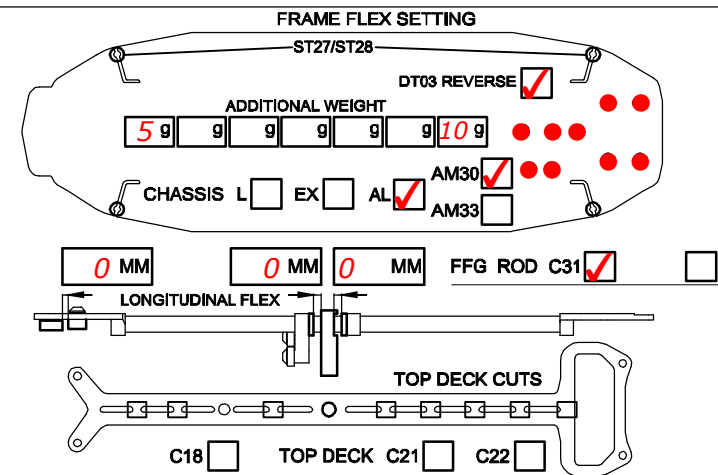

TIRES		FRONT	REAR
BRAND	<i>RIDE</i>	<i>RIDE</i>	<i>RIDE</i>
INSERTS			
WHEELS			
ADDITIVE	<i>LRP 2</i>	<i>LRP 2</i>	<i>LRP 2</i>

MOTOR LAYOUT LONG.	<input checked="" type="checkbox"/>	TRANS.	<input type="checkbox"/>	MOTOR	<i>LRP X20 4.5T</i>				
SERVO LAYOUT LEFT	<input checked="" type="checkbox"/>	RIGHT	<input type="checkbox"/>	SERVO	<i>Awesomatix A700L-BLS</i>				
ESC LAYOUT LEFT	<input checked="" type="checkbox"/>	RIGHT	<input type="checkbox"/>	ESC	<i>LRP Flow WorksTeam</i>				
BAT. LAYOUT R1	<input type="checkbox"/>	R2	<input type="checkbox"/>	F1	<input checked="" type="checkbox"/>	F2	<input type="checkbox"/>	BATTERY	<i>LRP 6000</i>
SPUR PINION		SD1		RECEIVER	<i>Sanwa 471</i>				
FINAL DRIVE RATIO				MOTOR OFFSET / MM					
BODY	<i>Bittydesign Striker-SR 3.0</i>			WING	<i>Bittydesign Hard</i>				

BEST LAPTIME _____ QUALIF. / FINAL POSITION _____ /
 ESC SETTING _____
 COMMENTS / IMPRESSIONS *AM6M on rear, FFG1.1,*
only one center screw on AM30-1 stiffener,
metal gears in the rear diff
 CONTACT _____