

NAME _____
 COUNTRY _____
 RACE _____
 TRACK _____

DATE _____ TEMP.°C AIR / TRACK _____ /
 TRACK CONDITION TECHNICAL MIXED FAST
 TRACTION LOW MEDIUM HIGH

FRONT

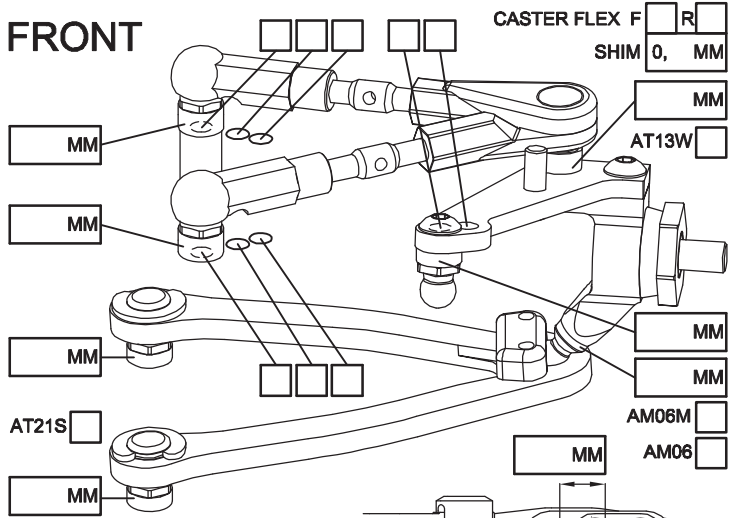

CAMBER ANGLE / ° _____
 CASTER ANGLE / ° _____
 TOE ANGLE / ° _____
 RIDE HEIGHT / MM _____
 DOWNSTOP / MM _____
 UPSTOP / MM _____
 STABILIZER Ø / MM _____
 LOW ARM C04M
 STEERING ARM STD
 WHEEL SPACER / MM _____
 FRONT DRIVE BALL DIFF GD3 SPOOL GD2
 DIFF OIL _____ DIFF WASHERS _____
 DOGBONE DRIVE ST17-1 ST11 ST12 BB ST02

SHOCKS SET

ROTOR STD
 SPRING STD S
 DAMPER D2.1
 ACTION SYM. ASYM.
 SRS/RHS ARR. I II

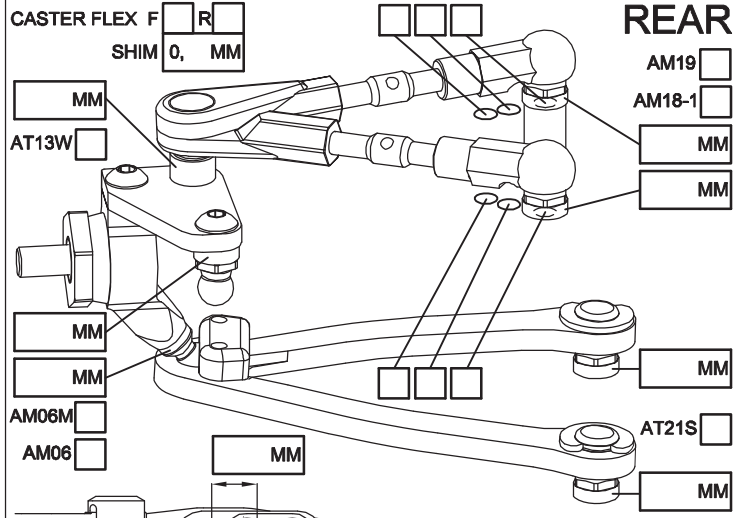

REAR

CAMBER ANGLE / ° _____
 CASTER ANGLE / ° _____
 TOE ANGLE / ° _____
 RIDE HEIGHT / MM _____
 DOWNSTOP / MM _____
 UPSTOP / MM _____
 STABILIZER Ø / MM _____
 LOW ARM C04M
 STEERING ARM STD
 WHEEL SPACER / MM _____
 REAR DRIVE BALL DIFF GD3R GD2
 DIFF OIL _____ DIFF WASHERS _____
 DOGBONE DRIVE ST11 ST12 BB ST17-1 EVD

SHOCKS SET

ROTOR STD
 SPRING STD S
 DAMPER D2.1
 ACTION SYM. ASYM.
 SRS/RHS ARR. I II

FRAME FLEX SETTING

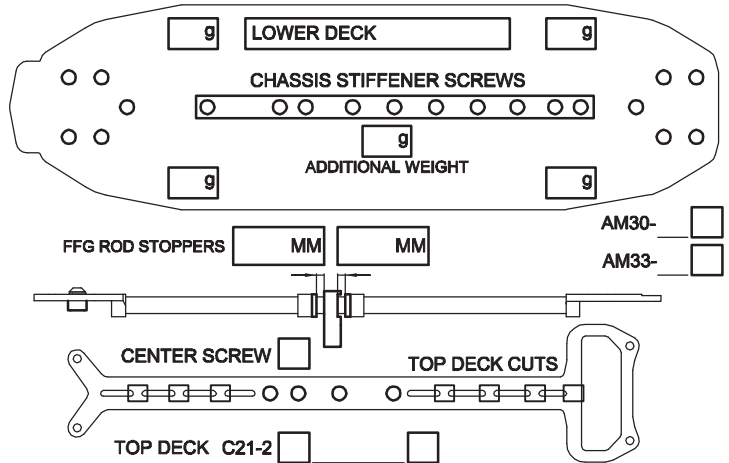

FL	FR	RL	RR	TIRES	FRONT	REAR
				BRAND		
				INSERTS		
				WHEELS		
				ADDITIVE		

MOTOR MOUNT MODE _____ MOTOR _____
 BAT. LAYOUT AM69 F1 F2 SERVO _____
 SD1 SD2 SD3 DRIVE RATIO _____ ESC _____
 SPUR _____ PINION _____ BATTERY _____
 BODY _____ RECEIVER _____
 WING _____ MOTOR OFFSET / MM _____

BEST LAPTIME _____ QUALIF. / FINAL POSITION _____ /

ESC SETTING _____
 COMMENTS / IMPRESSIONS _____

 CONTACT _____

STEERING POST

