

NAME _____
 COUNTRY _____
 RACE _____
 TRACK _____

DATE _____ TEMP. °C AIR / TRACK _____ /
 TRACK CONDITION TECHNICAL MIXED FAST
 TRACTION LOW MEDIUM HIGH

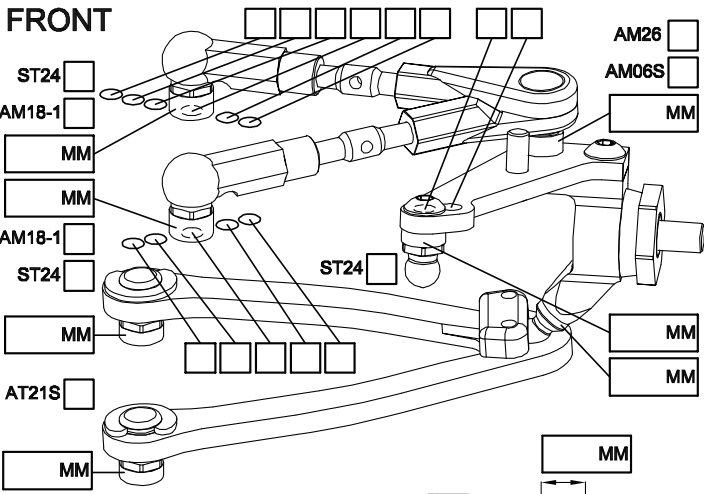

FRONT

ST24
 AM18-1
 MM
 MM
 AM18-1
 ST24
 MM
 AT21S
 MM

CAMBER ANGLE / ° _____
 CASTER ANGLE / ° _____
 TOE ANGLE / ° _____
 RIDE HEIGHT / MM _____
 DOWNSTOP / MM _____
 UPSTOP / MM _____
 STABILIZER Ø / MM _____
 LOW ARM STD _____
 STEERING ARM STD _____
 WHEEL SPACER / MM _____
 FRONT DRIVE BALL DIFF GEAR DIFF SPOOL ONE-WAY
 DIFF SET LOOSE MEDIUM TIGHT OIL # _____
 DOGBONE DRIVE BUSHING C-DRIVE BB EVD

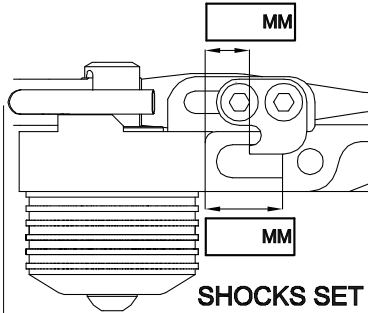

SPRING STD S
 DAMPER #6 #3
 ACTION SYM. ASYM.
 SRS/RHS ARR. I II

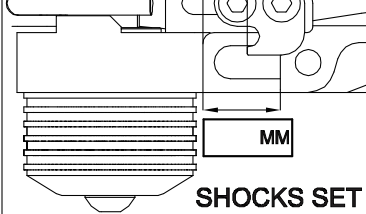
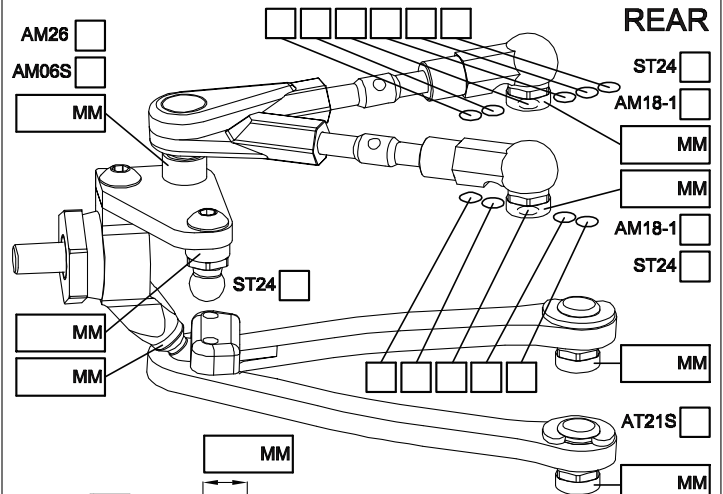

SPRING STD S
 DAMPER #6 #3
 ACTION SYM. ASYM.
 SRS/RHS ARR. I II

REAR

AM26
 AM06S
 MM
 ST24
 AM18-1
 MM
 MM
 AM18-1
 ST24
 MM
 AT21S
 MM

CAMBER ANGLE / ° _____
 CASTER ANGLE / ° _____
 TOE ANGLE / ° _____
 RIDE HEIGHT / MM _____
 DOWNSTOP / MM _____
 UPSTOP / MM _____
 STABILIZER Ø / MM _____
 LOW ARM STD _____
 STEERING ARM STD _____
 WHEEL SPACER / MM _____
 REAR DRIVE BALL DIFF GEAR DIFF
 DIFF SET LOOSE MEDIUM TIGHT OIL # _____
 DOGBONE DRIVE BUSHING C-DRIVE BB EVD

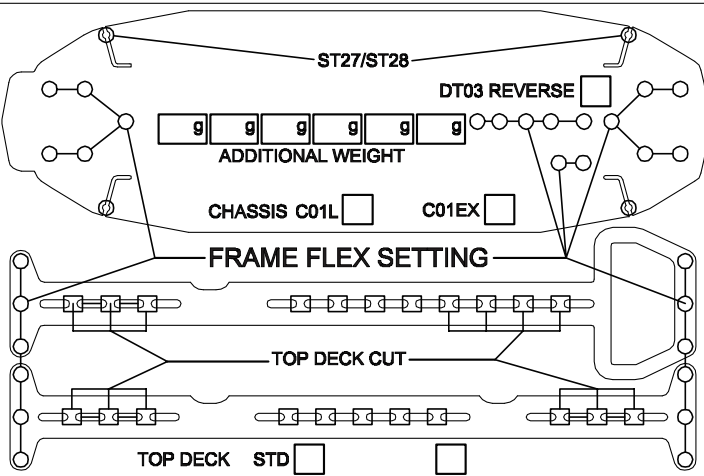

FL	FR	RL	RR	TIRES	FRONT	REAR
				BRAND		
				INSERTS		
				WHEELS		
				ADDITIVE		

MOTOR LAYOUT LONG. TRANS. MOTOR _____
 SERVO LAYOUT LEFT RIGHT SERVO _____
 ESC LAYOUT LEFT RIGHT ESC _____
 BAT. LAYOUT R1 R2 F1 F2 BATTERY _____
 SPUR PINION _____ RECEIVER _____
 FINAL DRIVE RATIO _____ MOTOR OFFSET / MM _____
 BODY _____ WING _____

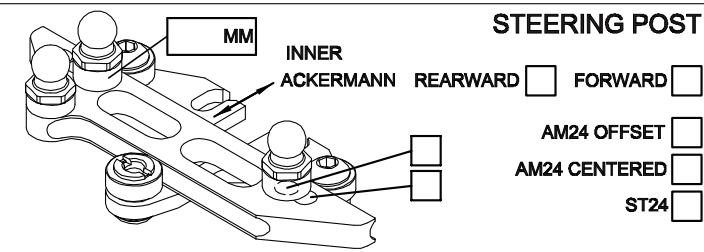

BEST LAPTIME _____ QUALIF. / FINAL POSITION _____ /
 ESC SETTING _____
 COMMENTS / IMPRESSIONS _____

 CONTACT _____