

NAME _____ DATE _____ TEMPERATURE AIR / TRACK °C / °C

COUNTRY _____ ASPHALT OUTDOOR INDOOR CARPET

RACE _____ TRACK CONDITION BUMPY FLAT TECHNICAL MIXED FAST

TRACK _____ TRACTION LOW MEDIUM HIGH

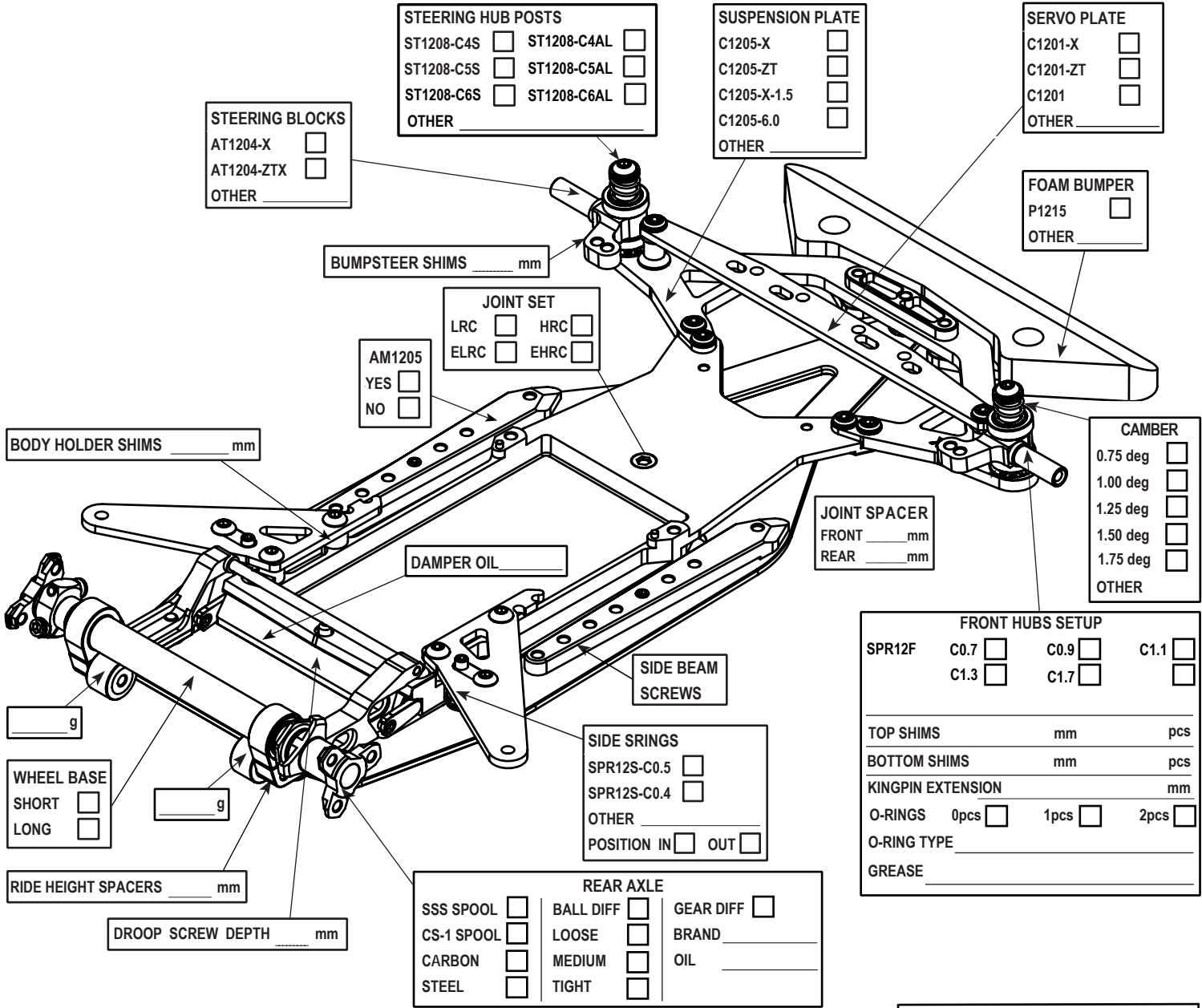

FRONT RIDE HEIGHT (FRH)	mm	FRONT DROOP (FD)	mm
REAR RIDE HEIGHT (RRH)	mm	REAR DOWNSTOP (RD)	mm
GAP UNDER DAMPER (GUD)	mm	TRACK WIDTH	
DROOP SCREW DEPTH (DSD)	mm	FRONT	mm
SPRING RETAINER HEIGHT (SRH)	mm	REAR	mm

BATTERY		SERVO	
BATTERY PLUGS	FRONT <input type="checkbox"/> BACK <input type="checkbox"/>	SERVOSAVER	
SERVO POSITION	LEFT <input type="checkbox"/> RIGHT <input type="checkbox"/>	SHIMS ON SERVOSAVER	
ESC POSITION	LEFT <input type="checkbox"/> RIGHT <input type="checkbox"/>	TOE OUT	
		STEER. TRAVEL IN ° OUT °	

TIRES	FRONT	REAR	FRONT		REAR	
BRAND						
TYPE						
DIAMETER	mm	mm				
ADDITIVE			TIME	min	TIME	min

MOTOR	TOTAL WEIGHT	g
SPUR PINION ROLLOUT	F/R WEIGHT DISTRIBUTION	
ESC	RECEIVER	
ESC SETTING	RADIO	
BODY	REAR BODY HEIGHT (SIDE DAMS)	mm
BEST LAP TIME	QUALIF. / FINAL POSITION	/

COMMENTS: