

Front	Suspension Geometry	Rear
	Outer Arm Mount Insert	
	Outer Mount Shims	
	Inner Arm Mount Insert	
	Inner Mount Shims	
	Anti-Roll Bar	

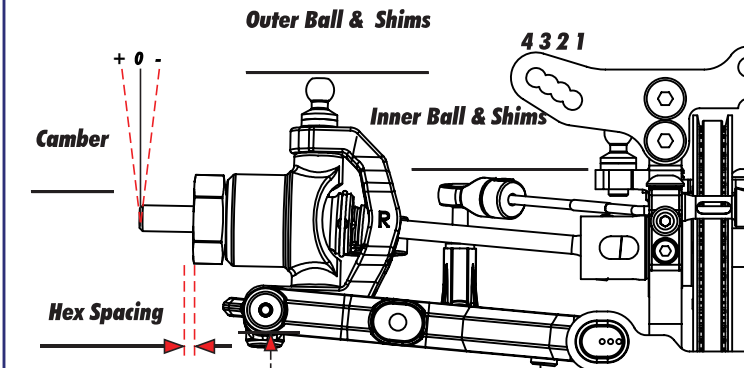

Shocks		
	Oil	
	Piston	
	Rebound	
	Spring	

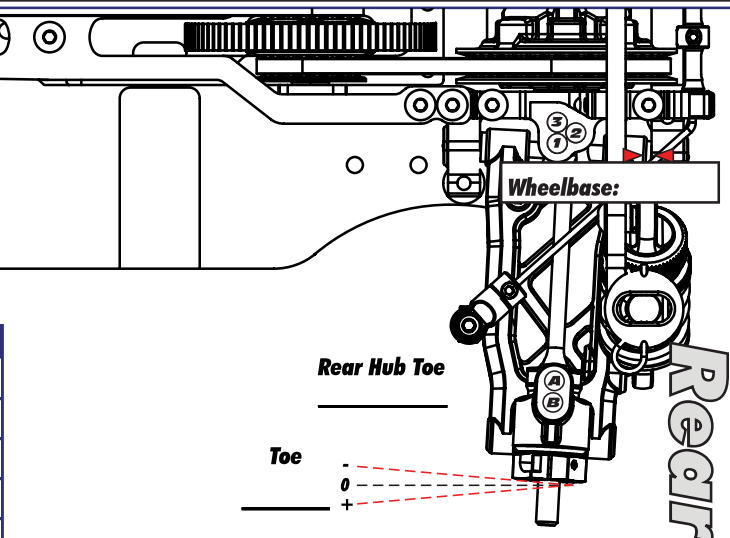
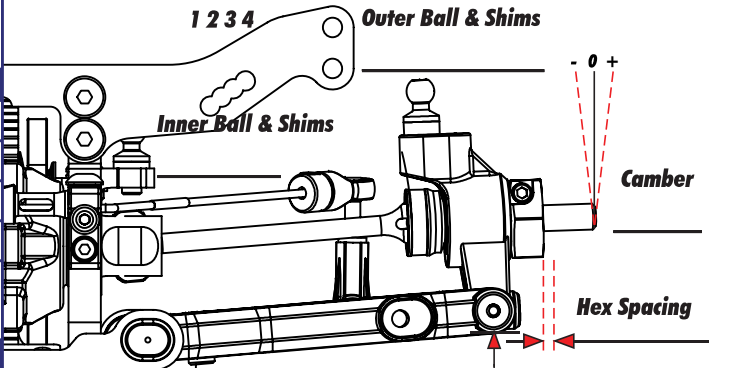

Differentials		
	Type	
	Setting	
	Cam Position	
	Belt Tension Number	

Inside of vehicle -3 DOT -1"	Arm Mount Inserts -2 DOT -1/2"	Outside of vehicle 1 DOT 0"	Wheel Base Shims +2 DOT +1/2"	Wheel Base Shims +3 DOT +1"
---	---	--	--	--

Cam Position

Low Mid-Low Mid-High High

Belt Tension Number

View from left side of car

Chassis	Top Plate
Motor	Gearing
	/

Tires		
	Type	
	Tire Diameter	
	Insert & Wheel	
	Additive & Amount	

Transmitter	Speed Control
Turning Circle:	E.S.C. Type:
Steering Expo:	E.S.C. Settings:
Brake E.P.:	Software Version:
Throttle Expo:	
Battery & Placement	Body & Wing