



Driver: Steffen Stein

Date: 08.10.2017

Track: MCCR Munzig indoor carpet

Event: LRP-HPI-Challenge

Qualify: _____

TQ:

Mains: A

Finish: 1

Best Lap Time: 9,999s

Track Info:

Size: Small Medium
 Large X-Large

Surface: Carpet Asphalt
 Indoor Outdoor

Traction: Low Medium
 High Wet

Condition: Bumpy Smooth

Temperature: Ambient Track

Vehicle Info:

Body: JConcepts LMP Layla

Weight: _____

Notes: _____

Shocks:

Piston: std.

Fluid: 45WT

Spring: Yokomo pink

Rebound: 0mm

Pre Load: 3,7mm

Free Length: 63,2mm

Notes: _____

Diff Setting:

Loose Medium Tight

Electronics:

Radio: Sanwa M12S

Servo: Sanwa SRG-BLS

EPA: Throttle: _____ % Brake: _____ %

ESC: LRP Flow competition

ESC Settings: _____

Motor: LRP X20 21.5T

Timing: _____

Pinion: 96 **Spur:** 33

Battery: LRP 4600 HV

Notes: _____

Tires:

Front Tires: Hudy

Front Insert: _____

Rear Tire: Hudy

Rear Insert: _____

Wheel (F/R): _____

Notes: _____

	Left	Right
Front Tire Additive:		
Additive Time:	10min	
Rear Tire Additive:		
Additive Time:	20/10min	

RESET

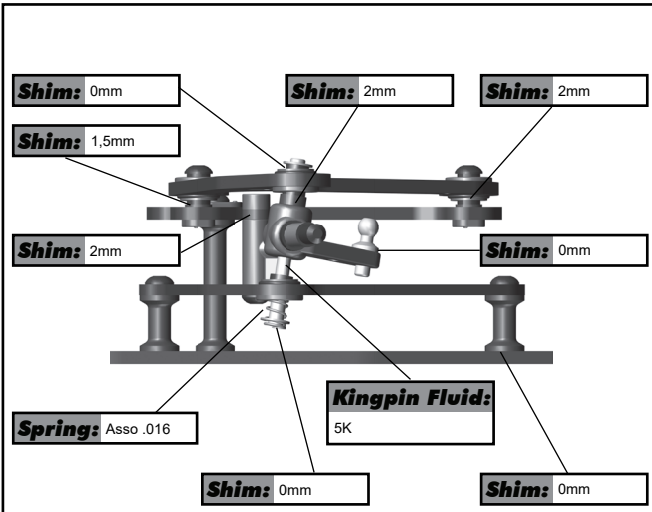
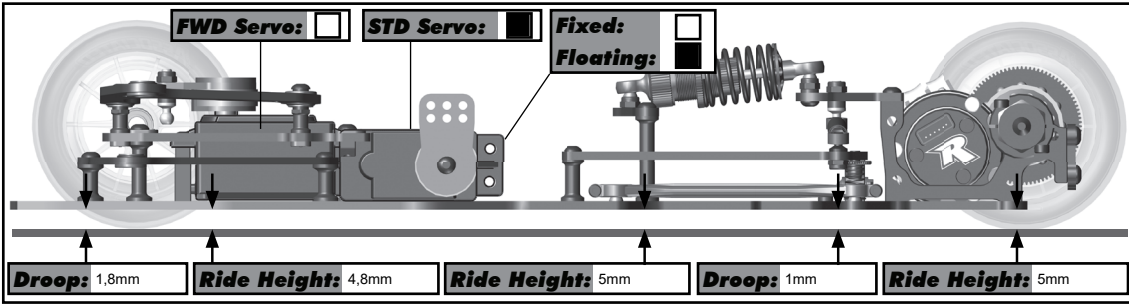

Camber: 1.0° 1.5° 2.0° 2.5°

Plastic:

Aluminum:

Caster: 3° 6° 9° 12°

Plastic:

Aluminum:

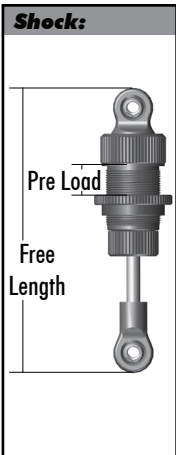

Side Spring:

Pre Load: 2,2mm

Spring: Asso blau

Damper Tube: _____

Fluid: 30K

Rear Wing Height: _____

