



**Driver:** Steffen Stei

**Date:** 29/04/18

**Track:** OSZ Henningsdorf

**Event:** HPI Challenge

**Qualify:** 1

**TQ:** ■

**Mains:** A

**Finish:** 1

**Best Lap Time:** 15,2s

**Track Info:**

**Size:** Small  Medium   
Large  X-Large

**Surface:** Carpet  Asphalt   
Indoor  Outdoor

**Traction:** Low  Medium   
High  Wet

**Condition:** Bumpy  Smooth

**Temperature:** Ambient  Track

**Vehicle Info:**

**Body:** Jconcepts Layla

**Weight:**

**Notes:**

**Shocks:**

**Piston:** 3 x 1.1

**Fluid:** Asso 40WT

**Spring:** Yokomo pink

**Rebound:** 0mm

**Pre Load:** 3,9mm

**Free Length:** 63,6mm

**Notes:**

**Diff Setting:**

Loose Medium Tight

**Electronics:**

**Radio:** Sanwa M12S

**Servo:** Sanwa SRG-BLS

**EPA:** Throttle: 100 % Brake: 75 %

**ESC:** LRP Flow Competition

**ESC Settings:**

**Motor:** LRP X20 21.5T

**Timing:** 30°

**Pinion:** 34 **Spur:** 96

**Battery:** LRP Graphene 2 4600

**Notes:**

**Tires:**

**Front Tires:** Hudy

**Front Insert:**

**Rear Tire:** Hudy

**Rear Insert:**

**Wheel (F/R):**

**Notes:**

<b>Front Tire Additive:</b> LRP Carpet 3 + 2	<b>Left</b>	<b>Right</b>
<b>Additive Time:</b> 20/10 min		
<b>Rear Tire Additive:</b> LRP Carpet 3 + 2	<b>Left</b>	<b>Right</b>
<b>Additive Time:</b> 20/10 min		

RESET

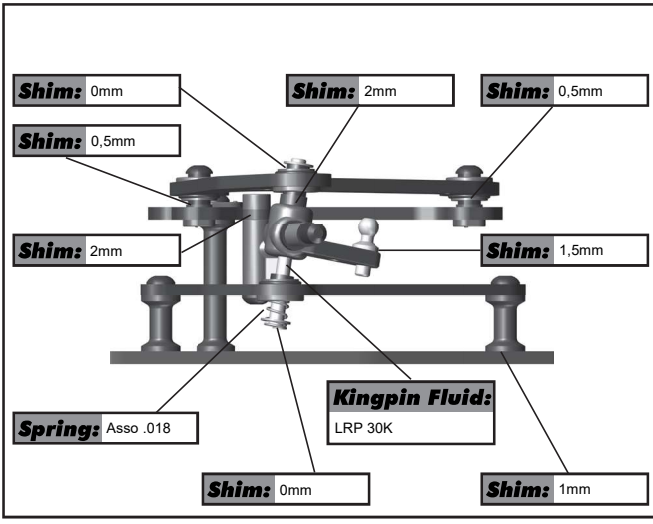
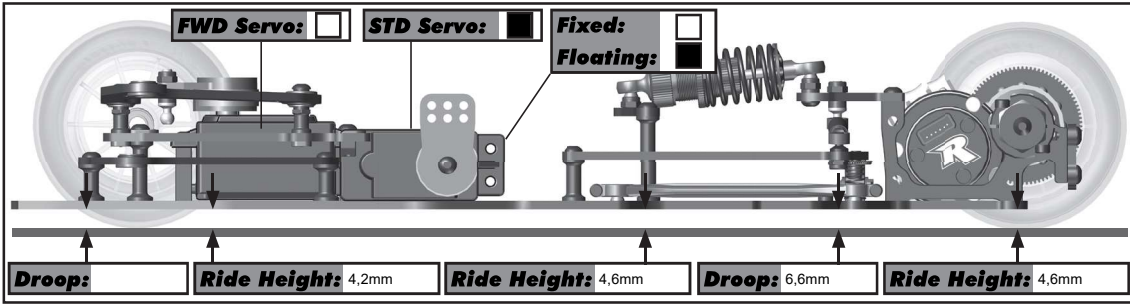

**Camber:** 1.0° 1.5° 2.0° 2.5°  
**Plastic:**      
**Aluminum:**

**Caster:** 3° 6° 9° 12°  
**Plastic:**      
**Aluminum:**

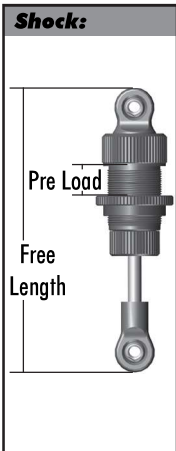

**Side Spring:**

**Pre Load:** 2mm

**Spring:** Xray 1.8

**Damper Tube:**

**Fluid:** LRP 50K

**Rear Wing Height:**

**Axle Height:** 1.0 0.75 0.5 0.25 0 0.25 0.5 0.75 1.0 STD + 1mm

**Rear Wing Angle:**

**Shim:** 0mm **Shim:** 0,5mm  
**Shim:** 0mm **Shim:** 0mm **Shim:**

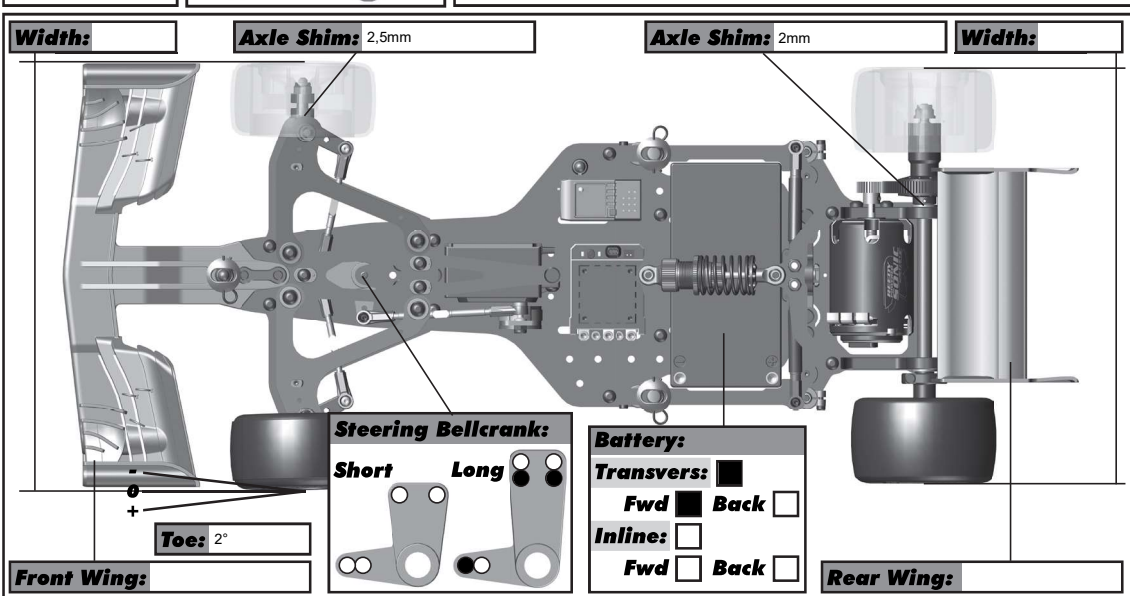

**:: For more setups, visit RC10.com and click on "Setup Sheets"**