

Track Info:

Size:
 Small Medium Large X-Large

Surface:
 Carpet Asphalt Indoor Outdoor

Traction:
 Low Medium High Wet

Condition: Bumpy Smooth

Temperature: Ambient Track

Notes:

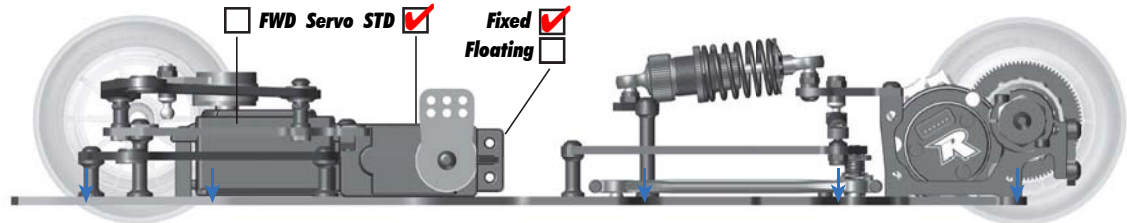

Droop: 1,0 **Ride Height:** 5,5 **Ride Height:** 5,5 **Droop:** 1,0 **Ride Height:** 5,5

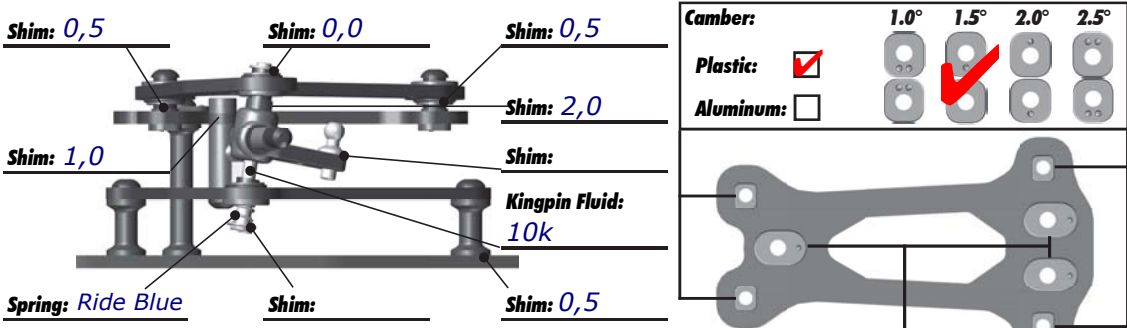

Camber: 1.0° 1.5° 2.0° 2.5°
 Plastic:
 Aluminum:

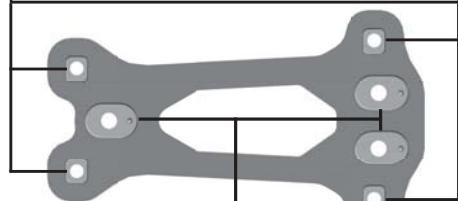

Caster: 3° 6° 9° 12°
 Plastic:
 Aluminum:

Damper Tube:
 Fluid: *30k*

Axle Height: 1.0 0.75 0.5 0.25 0 0.25 0.5 0.75 1.0 STD +1mm

Vehicle Info:

Body: *Protoform F15*

Weight:

Notes:
Mountend rear wingbracket upside down

Shock:

Piston: *3x1.1*

Fluid: *350cst*

Spring: *12.5lb*

Rebound: *25%*

Pre Load: *6,0mm*

Free Length: *63,5mm*

Notes:

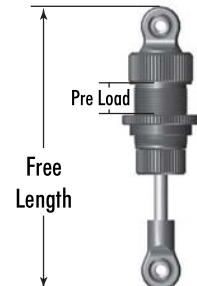

Electronics:

Radio: *Futaba 4PK*

Servo: *Sanwa SDX701*

EPA: Throttle: *100* % Brake: *70* %

ESC: *Reds TX120/LRP Flow*

ESC Settings: *Blinky*

Motor: *Hobbywing 21,5t*

Timing: *Zero timing*

Pinion: *42t* **Spur:** *84t*

Battery: *Gens Ace 5000*

Notes:

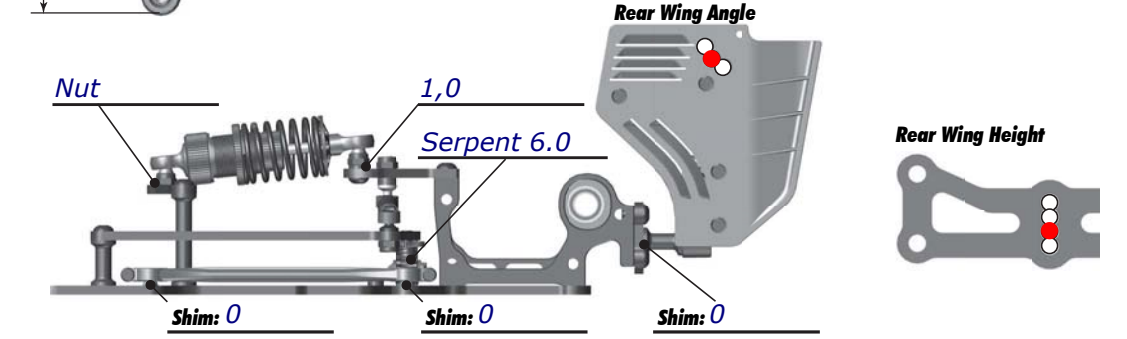

Width: 180 **Axle Shim:** 0 **Axle Shim:** 1,0 **Width:** 182

Tires:

Front Tires: *Ride XR*

Front Insert:

Rear Tire: *Ride XR*

Rear Insert:

Wheel (F/R):

Notes:

Front Tire Additive:
MG blue
 Additive Time: *10 min*

Rear Tire Additive:
MG blue
 Additive Time: *30 min*

Left Right

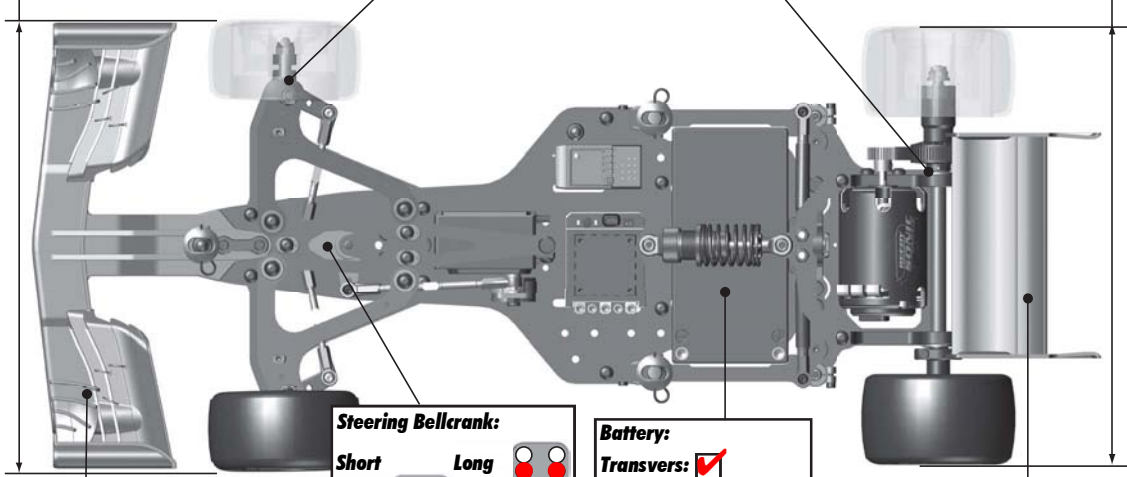

Front Wing: *Kit, no sideflaps*

Steering Bellcrank: Short Long

Battery: Transversers: Back
 Fwd Back
 Inline: Fwd Back

Rear Wing: *Kit*