

Track Info:

Size:	Small <input type="checkbox"/>	Medium <input checked="" type="checkbox"/>
	Large <input type="checkbox"/>	X-Large <input type="checkbox"/>
Surface:	Carpet <input type="checkbox"/>	Asphalt <input type="checkbox"/>
	Indoor <input type="checkbox"/>	Outdoor <input type="checkbox"/>
Traction:	Low <input type="checkbox"/>	Medium <input type="checkbox"/>
	High <input checked="" type="checkbox"/>	Wet <input type="checkbox"/>
Condition:	Bumpy <input type="checkbox"/>	Smooth <input checked="" type="checkbox"/>
Temperature:	Ambient <input type="checkbox"/>	Track <input checked="" type="checkbox"/>

Vehicle Info:

Body: Protoform '13
Weight: 1054
Notes: Diff built with Tamiya AW grease
Shock:
Piston: 3x1.1
Fluid: 30wt
Spring: Black
Rebound: 0
Pre Load: 6.5mm
Free Length: 63.75
Notes:

Diff Setting:

<input type="checkbox"/>	<input type="checkbox"/>	<input type="checkbox"/>	<input type="checkbox"/>	<input checked="" type="checkbox"/>
Loose		Medium		Tight

Electronics:

Radio: Airtronics M12
Servo: Airtronics 94746
EPA: Throttle: % Brake: %
ESC: HW XR10 Pro Stock Spec
ESC Settings:
Motor: Motiv MC2 25.5
Timing: 35
Pinion: 32 Spur: 88
Battery: Trinity white carbon hv 4000mah 100c
Notes:

Tires:

Front Tires: CRC
Front Insert: stock
Rear Tire: CRC
Rear Insert: stock
Wheel (F/R): CRC
Notes: front and rear sidewalls glued
Front Tire Additive: SXT Lite
Additive Time: 5 mins
Rear Tire Additive: SXT Lite
Additive Time: 5 mins

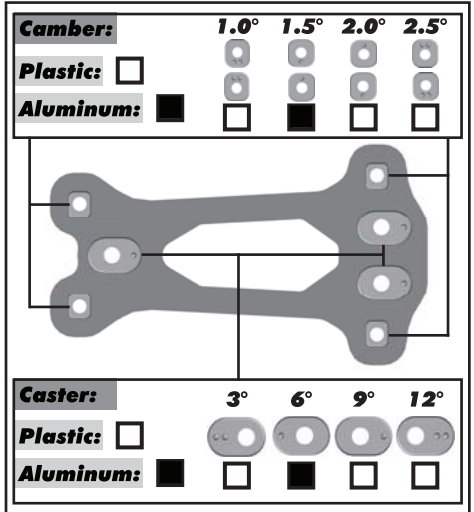
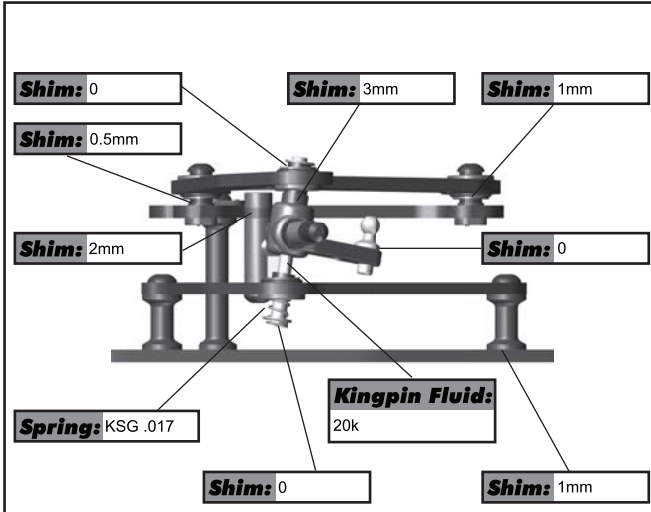
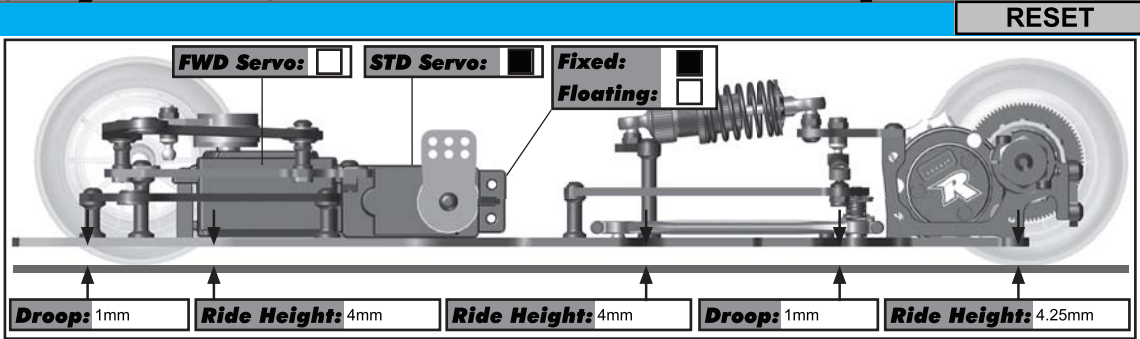
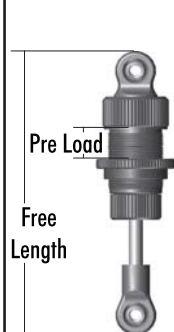
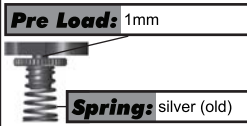
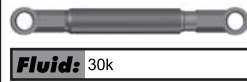
Shock:

Side Spring:

Damper Tube:

Rear Wing Height:
