

### Track Info:

**Size:** Small  Medium   
 Large  X-Large

**Surface:** Carpet  Asphalt   
 Indoor  Outdoor

**Traction:** Low  Medium   
 High  Wet

**Condition:** Bumpy  Smooth

**Temperature:** Ambient \_\_\_\_\_ Track \_\_\_\_\_

**Notes:**

### Vehicle Info:

**Body:** \_\_\_\_\_

**Weight:** \_\_\_\_\_

**Notes:**

### Shock:

**Piston:** \_\_\_\_\_

**Fluid:** \_\_\_\_\_

**Spring:** \_\_\_\_\_

**Rebound:** \_\_\_\_\_

**Pre Load:** \_\_\_\_\_

**Free Length:** \_\_\_\_\_

**Notes:**

### Electronics:

**Radio:** \_\_\_\_\_

**Servo:** \_\_\_\_\_

**EPA:** Throttle: \_\_\_\_\_ % Brake: \_\_\_\_\_ %

**ESC:** \_\_\_\_\_

**ESC Settings:** \_\_\_\_\_

**Motor:** \_\_\_\_\_

**Timing:** \_\_\_\_\_

**Pinion:** \_\_\_\_\_ **Spur:** \_\_\_\_\_

**Battery:** \_\_\_\_\_

**Notes:**

### Tires:

**Front Tires:** \_\_\_\_\_

**Front Insert:** \_\_\_\_\_

**Rear Tire:** \_\_\_\_\_

**Rear Insert:** \_\_\_\_\_

**Wheel (F/R):** \_\_\_\_\_

**Notes:**

	Left	Right
<b>Front Tire Additive:</b>	<input type="text"/>	<input type="text"/>
<b>Additive Time:</b>	<input type="text"/>	<input type="text"/>
<b>Rear Tire Additive:</b>	<input type="text"/>	<input type="text"/>
<b>Additive Time:</b>	<input type="text"/>	<input type="text"/>

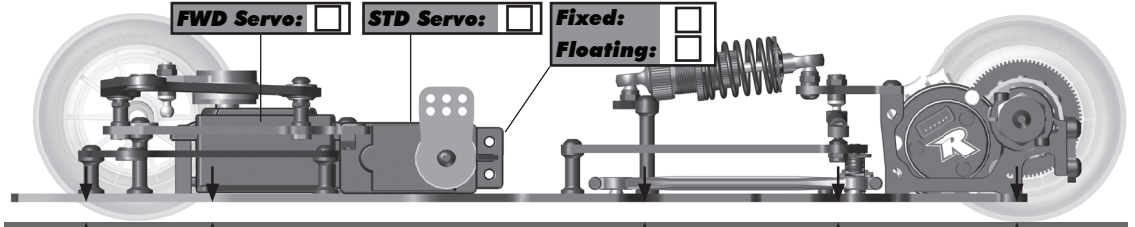

**Droop:** \_\_\_\_\_ **Ride Height:** \_\_\_\_\_ **Ride Height:** \_\_\_\_\_ **Droop:** \_\_\_\_\_ **Ride Height:** \_\_\_\_\_

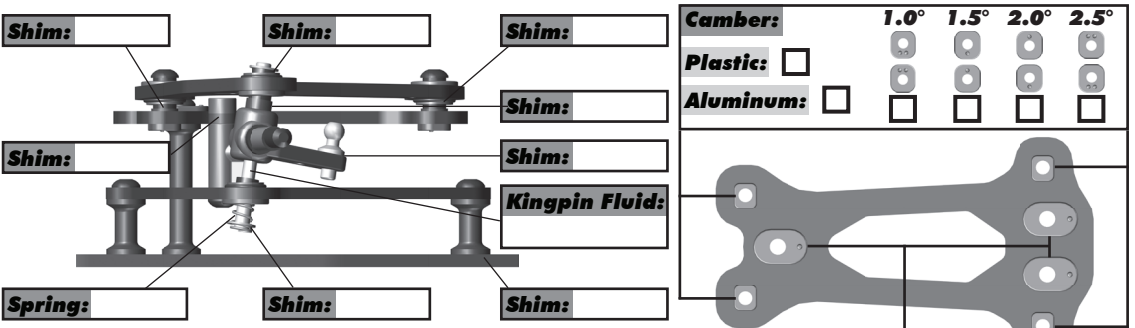

**Shim:** \_\_\_\_\_ **Shim:** \_\_\_\_\_ **Shim:** \_\_\_\_\_ **Shim:** \_\_\_\_\_ **Shim:** \_\_\_\_\_ **Shim:** \_\_\_\_\_

**Spring:** \_\_\_\_\_ **Shim:** \_\_\_\_\_ **Shim:** \_\_\_\_\_

**Pre Load** **Free Length**

**Damper Tube:** \_\_\_\_\_ **Fluid:** \_\_\_\_\_

**Caster:** 3° 6° 9° 12°  
 Plastic:  Aluminum:

**Axle Height:** 1.0 0.75 0.5 0.25 0 0.25 0.5 0.75 1.0 STD +1mm

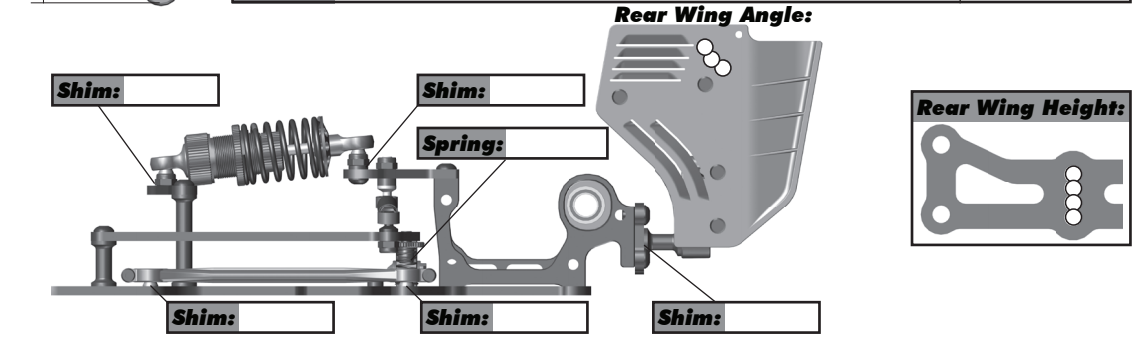

**Width:** \_\_\_\_\_ **Axle Shim:** \_\_\_\_\_ **Axle Shim:** \_\_\_\_\_ **Width:** \_\_\_\_\_

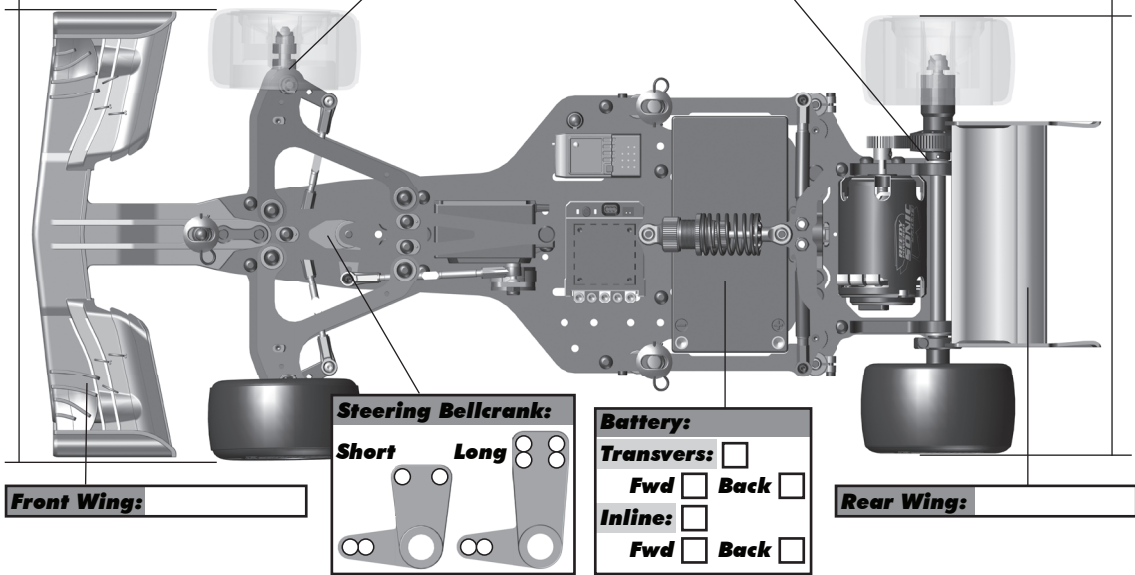

**Front Wing:** \_\_\_\_\_ **Steering Bellcrank:** Short Long   **Battery:** Transvers:  Fwd  Back  Inline:  Fwd  Back  **Rear Wing:** \_\_\_\_\_