

RACE

TRACK

NAME

CITY

DATE

TEMPERATURE		AIR	TRACK	
QUALIFYING	BEST LAP TIME	FINAL	RACE LENGTH	
	SEC		MIN	

TRACK CONDITION

CARPET     ASPHALT     INDOOR     OUTDOOR

BUMPY     SMOOTH

TECHNICAL     MIXED     FAST

TRACTION  LOW     MEDIUM     HIGH

FRONT	TRANSMISSION	REAR
<input type="checkbox"/> GEAR DIFF	<input type="checkbox"/> GEAR DIFF	
<input type="text"/>	CST	<input type="text"/>
<input type="checkbox"/> ONE WAY	<input type="checkbox"/> SPOOL	Nbr of Gears <input type="checkbox"/> 2 <input type="checkbox"/> 4

MOTOR	ESC		
PINION DP	T	SPUR GEAR DP	T
FINAL DRIVE RATIO (IR = 2.0)			

FRONT	REAR		
<input type="text"/>	CST	OIL	<input type="text"/>
<input type="text"/>	SPRING	<input type="text"/>	
<input type="text"/>	PISTON	<input type="text"/>	
<input type="text"/>	% REBOUND	<input type="text"/>	%

TIRES

TIRES

RIM

INSERTS

ADDITIVE

SURFACE

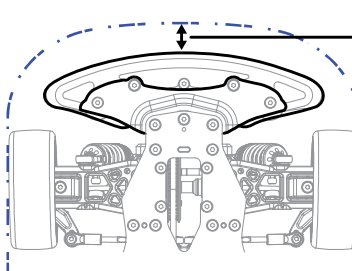

BODY MOUNT DISTANCE  mm

Bumper  Standard  Cut

BODY	WING
------	------

ATS SETUP

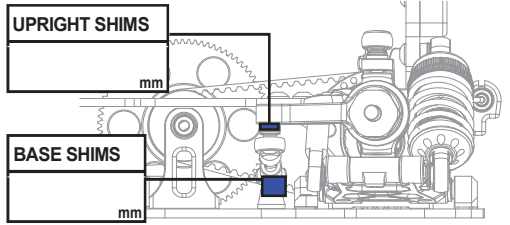

UPRIGHT SHIMS  mm

BASE SHIMS  mm

