

RACE

TRACK

NAME

CITY / COUNTRY

DATE

TEMPERATURE	AIR	TRACK
QUALIFYING POSITION	BEST LAP TIME	FINAL POSITION
	SEC	MIN

TRACK CONDITION

CARPET ASPHALT

TECHNICAL MIXED FAST

TRACTION LOW MEDIUM HIGH

FRONT	TRANSMISSION	REAR
GEAR DIFF	GEAR DIFF	GEAR DIFF
<input type="checkbox"/> CST	<input type="checkbox"/> CST	<input type="checkbox"/> CST
<input type="checkbox"/> ONE WAY	Number of Gears	
<input type="checkbox"/> SPOOL	<input type="checkbox"/> 2 <input type="checkbox"/> 4	

PINION	T	SPUR GEAR	T
R10 Internal Ration			
FINAL DRIVE RATIO			

OIL	FRONT	SHOCK PISTON	REAR	OIL
<input type="checkbox"/> 3 HOLE	<input type="checkbox"/> 3 HOLE	<input type="checkbox"/> 3 HOLE	<input type="checkbox"/> 3 HOLE	<input type="checkbox"/> 3 HOLE
<input type="checkbox"/> 4 HOLE	<input type="checkbox"/> 4 HOLE	<input type="checkbox"/> 4 HOLE	<input type="checkbox"/> 4 HOLE	<input type="checkbox"/> 4 HOLE
CST	HOLE SIZE	CST		CST
SPRING	mm	SPRING		
	mm			

	TIRES	
	RIM	
	INSERTS	
	ADDITIVE	

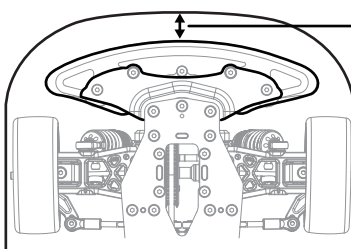

Bumper Standard Cut

BODY MOUNT DISTANCE mm

BODY WING

ATS SETUP

ATS Upright Shims mm

ATS Base Shims mm

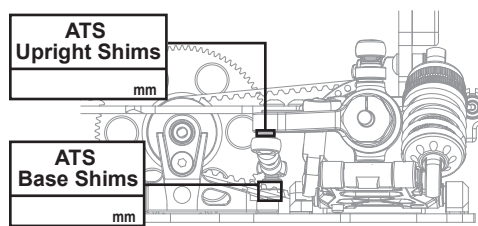

NOTE

