

RACE	
TRACK	
NAME	
CITY	
DATE	

TEMPERATURE		AIR	TRACK	
QUALIFYING	BEST LAP TIME	FINAL	RACE LENGTH	
	SEC		MIN	
TRACK CONDITION				
<input type="checkbox"/>	CARPET	<input type="checkbox"/>	ASPHALT	
<input type="checkbox"/>	INDOOR	<input type="checkbox"/>	OUTDOOR	
<input type="checkbox"/>	TECHNICAL	<input type="checkbox"/>	MIXED	
<input type="checkbox"/>	LOW	<input type="checkbox"/>	MEDIUM	
<input type="checkbox"/>		<input type="checkbox"/>	FAST	
<input type="checkbox"/>		<input type="checkbox"/>	HIGH	

FRONT		TRANSMISSION		REAR	
<input type="checkbox"/>	CST	GEAR DIFF	<input type="checkbox"/>	CST	
<input type="checkbox"/>	ONE-WAY	Number of Gear		<input type="checkbox"/>	
<input type="checkbox"/>	SPOOL	<input type="checkbox"/>	2	<input type="checkbox"/>	4

MOTOR	ESC				
PINION	DP	T	SPUR GEAR	DP	T
FINAL DRIVE RATIO (IR = 2.0)					

FRONT		SHOCKS		REAR	
<input type="checkbox"/>	CST	OIL	<input type="checkbox"/>	CST	
<input type="checkbox"/>		SPRING	<input type="checkbox"/>		
<input type="checkbox"/>		PISTON	<input type="checkbox"/>		
<input type="checkbox"/>	%	REBOUND	<input type="checkbox"/>	%	

	TIRES	
	RIM	
	INSERTS	
	ADDITIVE	
	SURFACE	

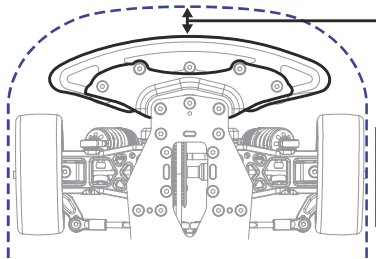

Bumper	
<input type="checkbox"/>	Standard
<input type="checkbox"/>	Cut
BODY MOUNT DIST.	
mm	

BODY	WING
------	------

ATS SETUP

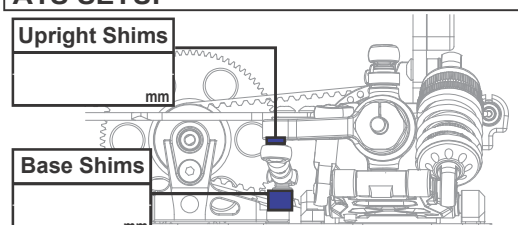

Upright Shims	
<input type="checkbox"/>	mm
Base Shims	
<input type="checkbox"/>	mm

FRONT

SHIM	mm
SHIM	mm
SHIM	mm
SHIM	mm

OFFSET	
<input type="checkbox"/>	-0.75 mm
<input type="checkbox"/>	0 mm
<input type="checkbox"/>	+0.75 mm

SHOCK POSITION

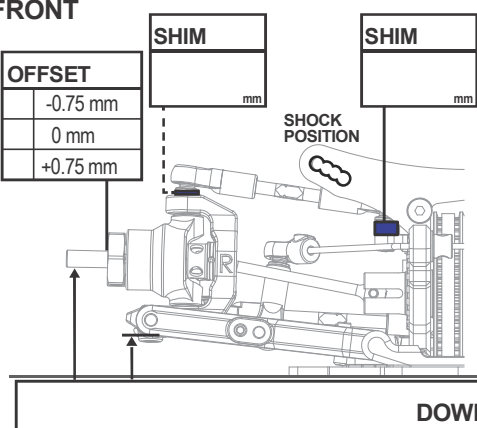

REAR

SHIM	mm
SHIM	mm
SHIM	mm
SHIM	mm

OFFSET	
<input type="checkbox"/>	-0.75 mm
<input type="checkbox"/>	0 mm
<input type="checkbox"/>	+0.75 mm

SHOCK POSITION

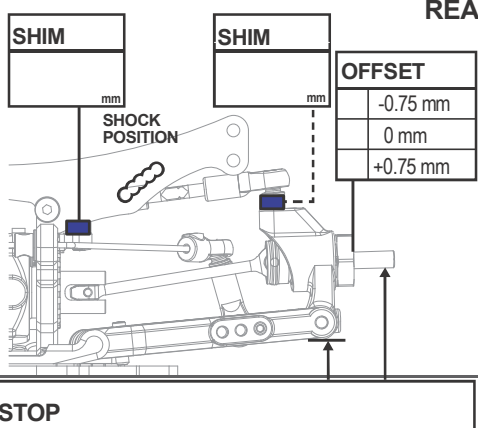

DOWNSTOP

mm mm mm mm

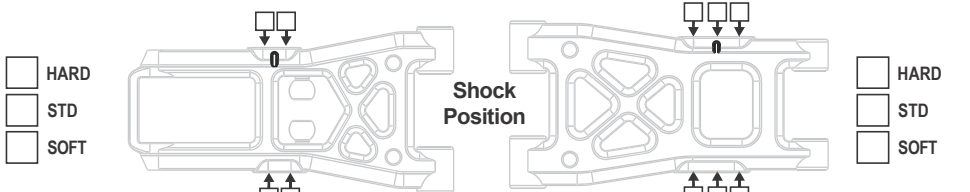

<input type="checkbox"/>	HARD
<input type="checkbox"/>	STD
<input type="checkbox"/>	SOFT

Shock Position

<input type="checkbox"/>	HARD
<input type="checkbox"/>	STD
<input type="checkbox"/>	SOFT

CAMBER

<input type="checkbox"/>		<input type="checkbox"/>	
--------------------------	--	--------------------------	--

C-HUB

<input type="checkbox"/>	HARD
<input type="checkbox"/>	STD

UPRIGHT

<input type="checkbox"/>	HARD
<input type="checkbox"/>	STD

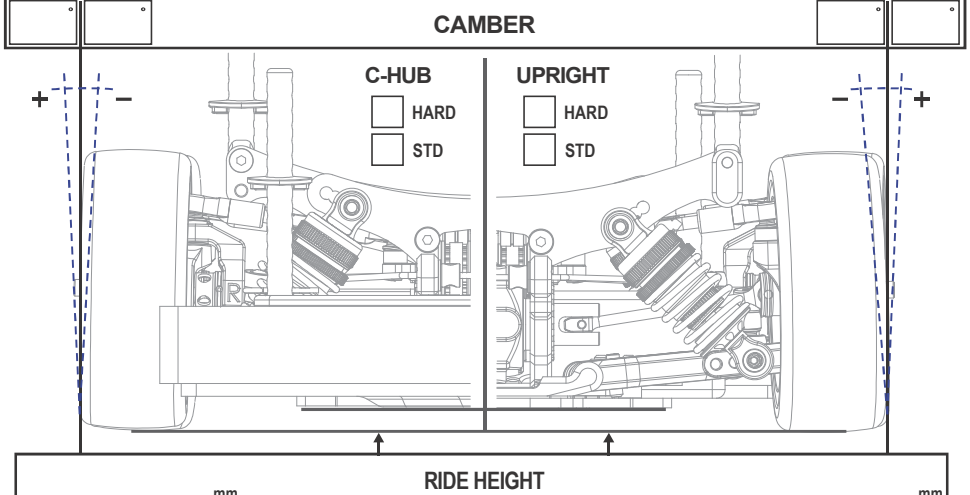

RIDE HEIGHT

mm mm

TOE	OUT	IN
ANTIROLL BAR		
mm		
BUMP STEER		
mm		
SHIM		
mm		
POSTS		
SHORT		
LONG		
ANTIROLL BAR		
R		
mm		
STIFFNER		
8.5		
BELL CRANK		
STANDARD		
20mm Alu		
22mm Alu		
RF BLOCK		
CUT SIDE		
<input type="checkbox"/>		
<input type="checkbox"/>		
RR BLOCK		
#		

TOP DECK	
mm	
ver	
CHASSIS	
mm	
ver	
DIFF HEIGHT	
HIGH	
LOW	

BATTERY FASTEN DIRECTION	
SIDE	
STANDARD	
BATTERY WEIGHT	
g	
NUT	
TOWER	
STEERING	
STANDARD	
FLOATING	
REAR ARM	
STANDARD	
ATS SYSTEM	
DIFF HEIGHT	
HIGH	
LOW	

FF	mm	FR	mm	ROLL CENTER SHIM	RF	mm	RR	mm
----	----	----	----	------------------	----	----	----	----

