

# A10MF-24 SET-UP SHEET

1/10 Electric Touring Car

# ARC

ver 2023.07

RACE	ACT State Titles
TRACK NAME	Kambah, Canberra
CITY / COUNTRY	Tony McMahon Canberra, Australia
DATE	September 2024

TEMPERATURE	AIR	TRACK
20c	20c	30c

QUALIFYING POSITION	BEST LAP TIME	FINAL POSITION	RACE LENGTH
2	22.22 SEC	1	6min MIN

TRACK CONDITION	<input type="checkbox"/> CARPET	<input checked="" type="checkbox"/> ASPHALT
<input type="checkbox"/> TECHNICAL	<input checked="" type="checkbox"/> MIXED	<input type="checkbox"/> FAST

TRACTION	<input checked="" type="checkbox"/> LOW	<input type="checkbox"/> MEDIUM	<input type="checkbox"/> HIGH
----------	---	---------------------------------	-------------------------------

### TRANSMISSION

GEAR DIFF OIL	NUMBER OF GEARS
<input type="checkbox"/> 500k CST	<input type="checkbox"/> 2 <input checked="" type="checkbox"/> 4

PINION	38 T	SPUR GEAR	90 T
FINAL DRIVE RATIO	4.5		

### SHOCK SET

<input type="checkbox"/> PDS FRONT	<input type="checkbox"/> PDS REAR
------------------------------------	-----------------------------------

FRONT		REAR	
300	CST	300	CST
2.5	SPRING	2.6	
4	1.1 mm	4	1.1 mm
0	%	0	%

### ANTI-ROLL BAR

FRONT	None mm	REAR	None mm
-------	---------	------	---------

TP radial	TIRES	TP radial	
None	ADDITIVE TIMING	None	
None	ADDITIVE	None	
FL	FR	RL	RR
TREATED AREA			

BODY MOUNT DISTANCE	
mm	

BODY	YRS 0.5	WING	Std
------	---------	------	-----

### NOTE

- Split top deck
- 40grams in bumper instead of 60g weight
- 4400 Fyrework lipo
- No ESC or motor fan
- No sway bars
- 1265g total weight
- SRT D1 lightweight servo
- used No warmers or additive

### FRONT

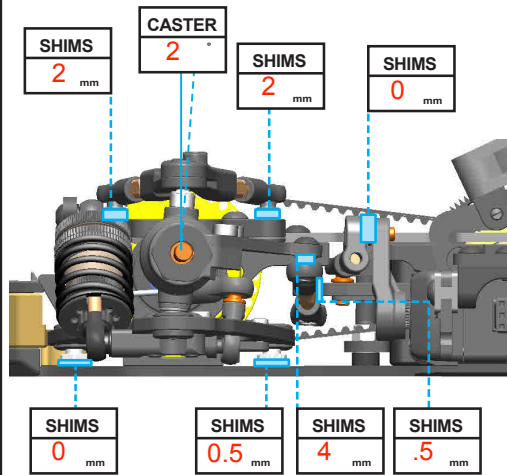

### REAR

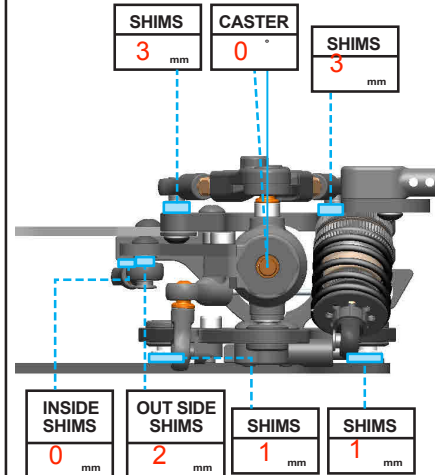

### FRONT

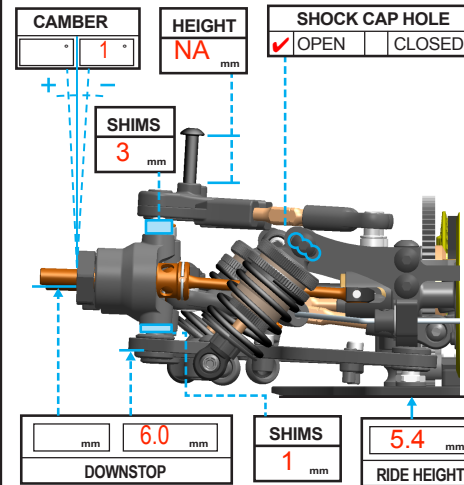

### REAR

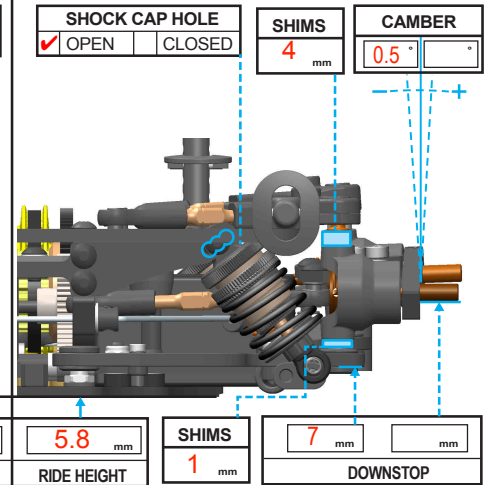

### CHASSIS SETUP

