

RACE

TRACK NAME

CITY / COUNTRY

DATE

TEMPERATURE	AIR	TRACK
QUALIFYING POSITION	BEST LAP TIME SEC	FINAL POSITION
		RACE LENGTH MIN
TRACK CONDITION		
<input type="checkbox"/> TECHNICAL	<input type="checkbox"/> CARPET	<input type="checkbox"/> ASPHALT
<input type="checkbox"/> LOW	<input type="checkbox"/> MIXED	<input type="checkbox"/> FAST
TRACTION <input type="checkbox"/> LOW <input type="checkbox"/> MEDIUM <input type="checkbox"/> HIGH		

TRANSMISSION

BELT FRONT  STD  SOFT

GEAR DIFF OIL  CST

REAR  STD  SOFT

NUMBER OF GEARS  2  4

PINION  T SPUR GEAR  T

FINAL DRIVE RATIO

SPRING  17mm  20mm

SUSPENSION

FRONT	OIL	REAR
W CST		W CST
<input type="text"/>	PDS	<input type="text"/>
<input type="text"/>	SPRING	<input type="text"/>
<input type="text"/>	HOLES / DIAMETER	<input type="text"/>
<input type="text"/>	REBOUND	<input type="text"/>
<input type="text"/>		<input type="text"/>

ANTI-ROLL BAR FRONT  mm REAR  mm

TIRES

ADDITIVE TIMING

ADDITIVE

FL  FR  RL  RR

TREATED AREA

BODY MOUNT DISTANCE  mm

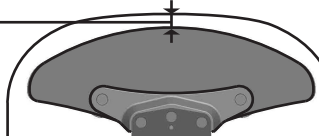

BODY  WING

NOTE

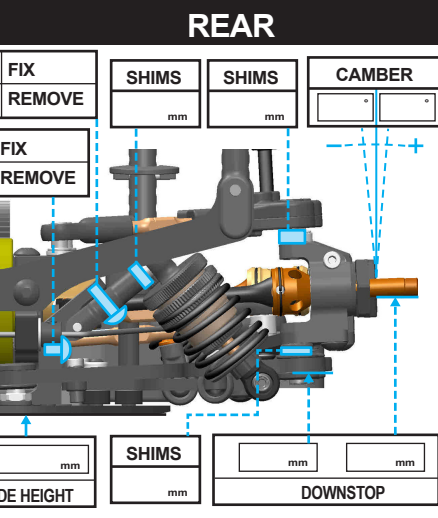
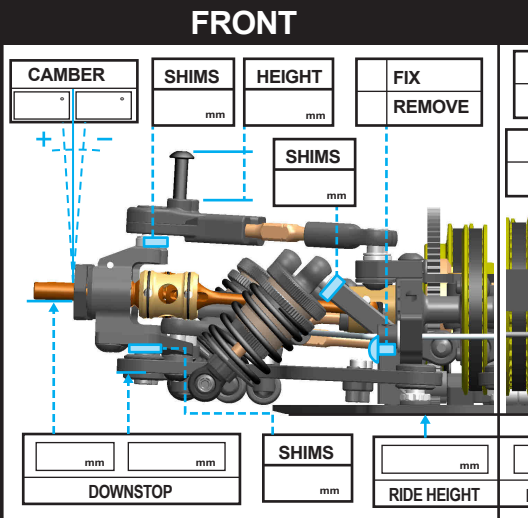
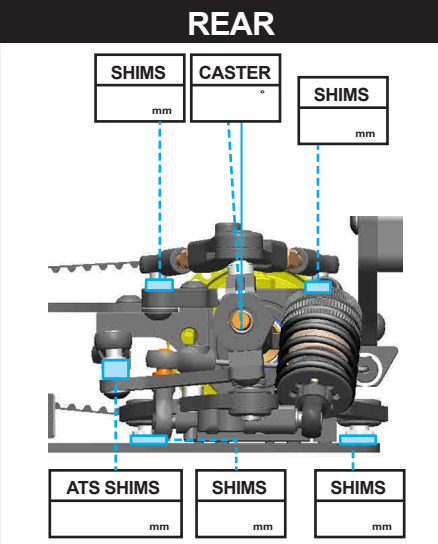
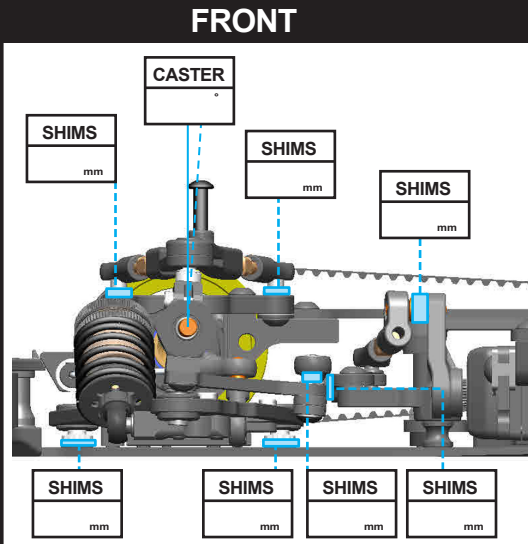

## CHASSIS SETUP

