

# M5 SETUP SHEET PRO

V10 SCALE RADIO CONTROL TOURING CAR

DRIVER	DATE		
CIRCUIT	EVENT		
FINAL POSITION	BEST LAP		
<input type="checkbox"/> Place (地點)	<input type="checkbox"/> Indoor (室內)	<input type="checkbox"/> Outdoor (室外)	
<input type="checkbox"/> Track (場地)	<input type="checkbox"/> Asphalt (瀝青)	<input type="checkbox"/> Carpet (地毯)	
<input type="checkbox"/> Traction (抓著力)	<input type="checkbox"/> High (高)	<input type="checkbox"/> Medium (中)	<input type="checkbox"/> Low (低)
<input type="checkbox"/> Track Condition (場地狀況)	<input type="checkbox"/> Flat (平坦)	<input type="checkbox"/> Bumpy (顛簸)	

FRONT (前方)

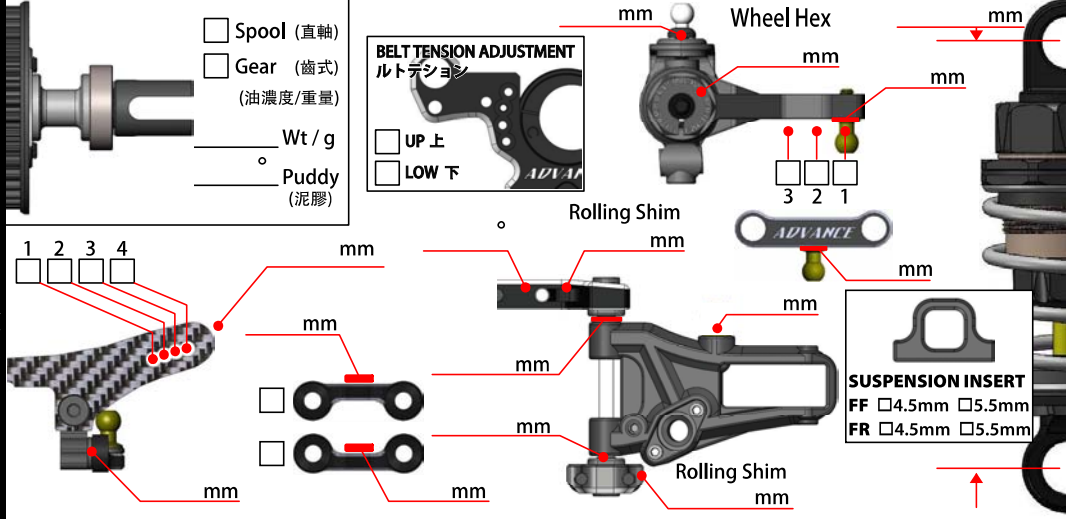

<b>shock absorber 減震器</b>	Ride Height (離地距)
Oil (油濃度)	mm
Piston (活塞) 2 3 4 Holes	Camber Angle (外傾角) °
Spring (彈簧)	Sway Bar (防傾桿) mm
Bladder Foam (油壓頂部海綿) Yes <input type="checkbox"/> No <input type="checkbox"/>	Droop (油壓行程) mm
Rebound (彈芯) %	Downstop (擺臂止限位) mm
Notes (備註)	Toe Angle (束角) °

REAR (後方)

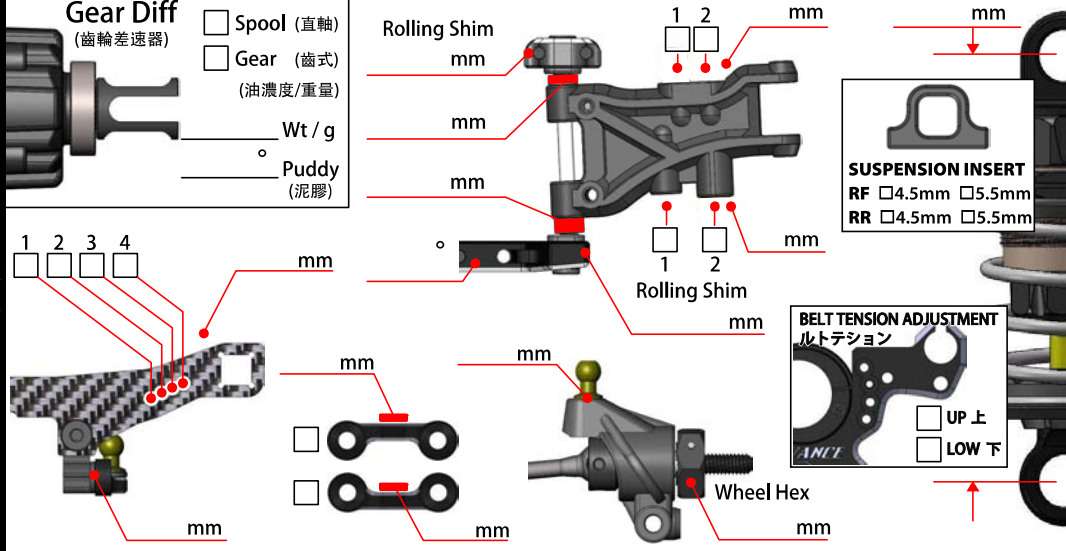

<b>shock absorber 減震器</b>	Ride Height (離地距)
Oil (油濃度)	mm
Piston (活塞) 2 3 4 Holes	Camber Angle (外傾角) °
Spring (彈簧)	Sway Bar (防傾桿) mm
Bladder Foam (油壓頂部海綿) Yes <input type="checkbox"/> No <input type="checkbox"/>	Droop (油壓行程) mm
Rebound (彈芯) %	Downstop (擺臂止限位) mm
Notes (備註)	Toe Angle (束角) °

OTHER (其他)

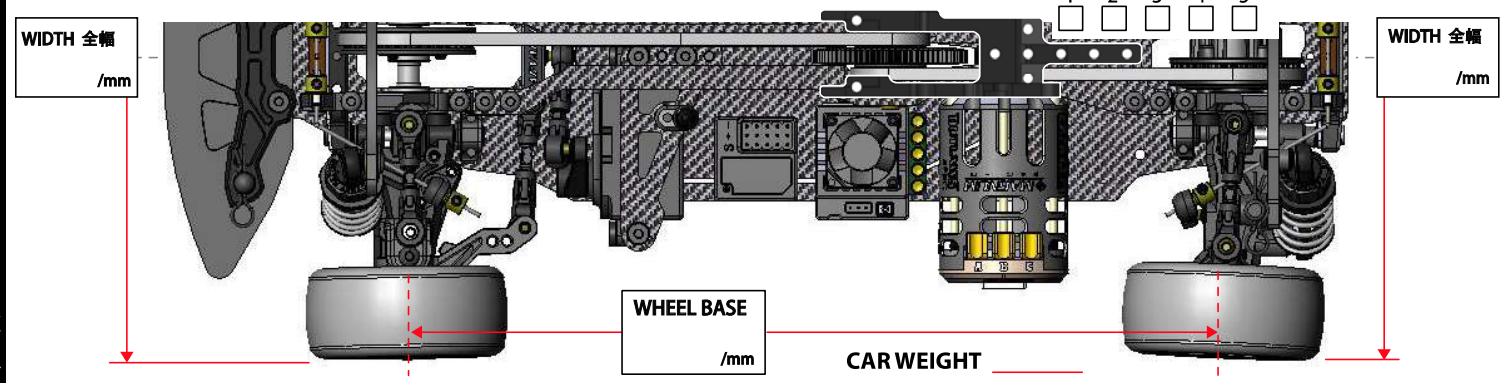

FRONT (前方)	REAR (後方)	Spur Gear (大減齒) T	Pinion Gear (摩打齒) T
Tire (胎皮)		Motor (馬達)	Battery (電池)
Compound (胎皮值)		ESC (電調)	Servo (伺服器)
Insert (胎胎)		Body (車殼)	Wing (風翼)
Wheel (輪圈)		Final Drive Ratio (齒比)	(Spur / Pinion x 1.9) : 1
Tire Treatment (胎水)			
Tire Warmer			