

ZERO ULTRA

1/18 SCALE RADIO CONTROL TOURING CHASSIS SETUP SHEET

DRIVER (賽員) Kit Chau DATE 03/26/2023

FINAL POSITION (決賽成績) A1 BEST LAP 9.600

CIRCUIT (賽道) GuangD CLASS (組別) BLNKY

| | | | |
|--|--|--|---|
| <input checked="" type="checkbox"/> PLACE (地點) | <input checked="" type="radio"/> INDOOR (室內) | <input type="radio"/> OUTDOOR (室外) | <input type="radio"/> OPEN STOCK |
| <input checked="" type="checkbox"/> TRACK (場地) | <input type="radio"/> ASPHALT (瀝青) | <input checked="" type="radio"/> CARPET (地毯) | <input checked="" type="radio"/> MODIFY |
| <input checked="" type="checkbox"/> TRACTION (抓着力) | <input type="radio"/> HIGH (高) | <input checked="" type="radio"/> MEDIUM (中) | <input type="radio"/> LOW (低) |
| <input checked="" type="checkbox"/> TRACK CONDITION (場地狀況) | <input checked="" type="radio"/> FLAT (平坦) | <input type="radio"/> BUMPY (顛簸) | |

FRONT (前方)

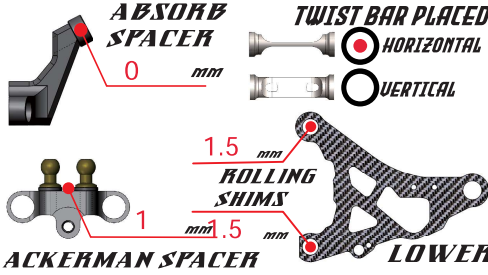
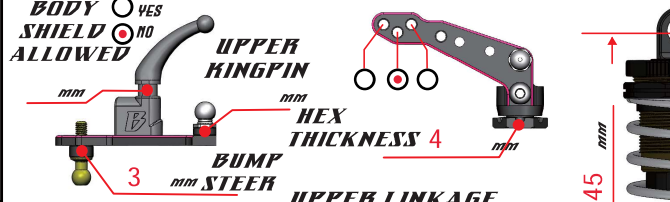
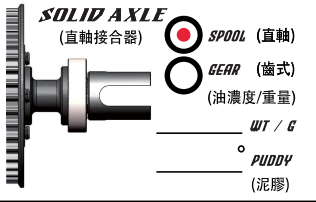

ABSORBER 減震器

OIL (油濃度) # 500

PISTON (活塞) ② ③ ④ HOLES 1.1 mm

SPRING (彈簧) Yokomo 2.4-2.9

BLADDER FOAM (油壓頂部海綿) YES NO

REBOUND (彈芯) 0 %

CASTER (傾角) 4 °

RIDE HEIGHT (離地距) 5 mm

CAMBER ANGLE (外傾角) 1.5 °

SWAY BAR (防傾桿) 1.2 mm

DROOP (油壓行程) 1.4 mm

DOWNSTOP (擺臂止限位) 6.5 mm

TOE ANGLE (束角) -1 °

REAR (後方)

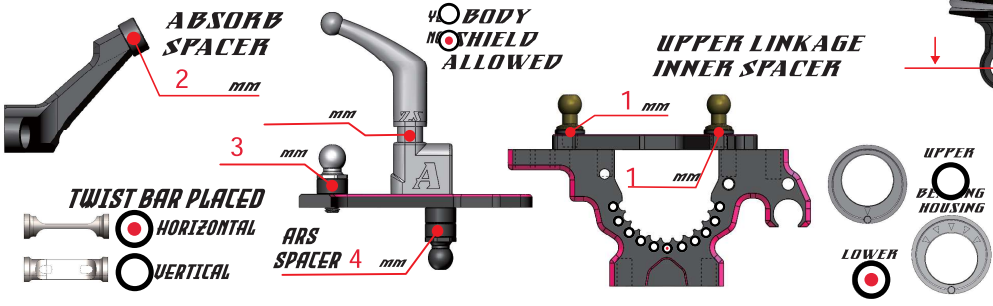
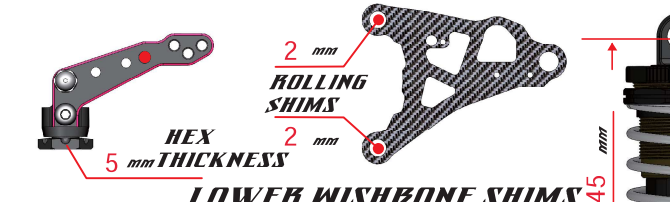

ABSORBER 減震器

OIL (油濃度) # 500

PISTON (活塞) ② ③ ④ HOLES 1.1 mm

SPRING (彈簧) Yokomo 2.0-2.3

BLADDER FOAM (油壓頂部海綿) YES NO

REBOUND (彈芯) 0 %

CASTER (傾角) 0 °

RIDE HEIGHT (離地距) 5.5 mm

CAMBER ANGLE (外傾角) 2 °

SWAY BAR (防傾桿) 1.1 mm

DROOP (油壓行程) 1.6 mm

DOWNSTOP (擺臂止限位) 6 mm

TOE ANGLE (束角) 2.5 °

OTHER (其他)

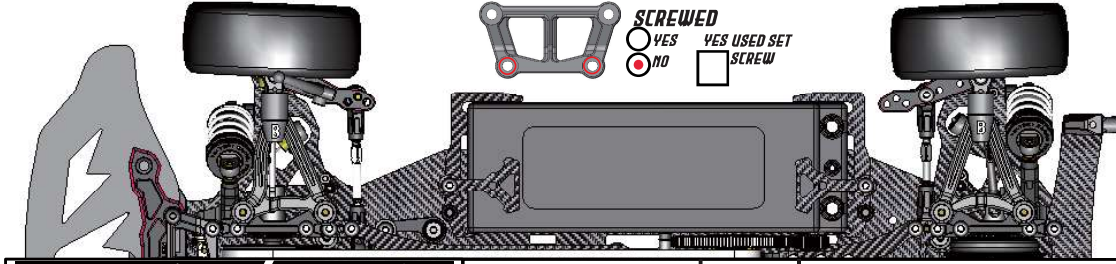
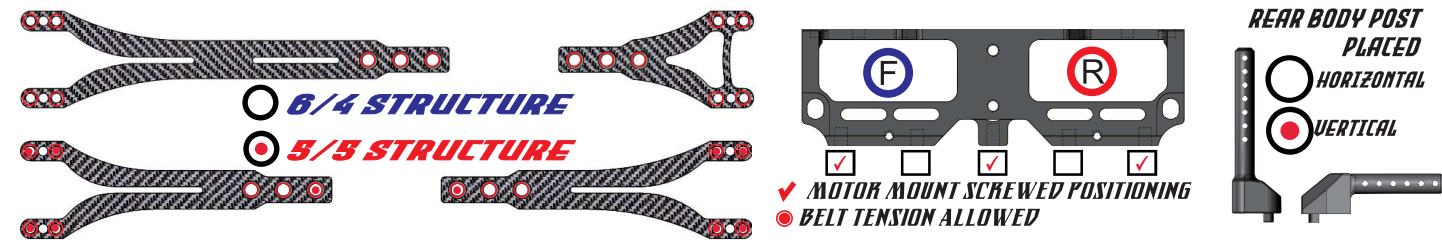

FRONT THREAD mm

REAR THREAD mm

WHEELBASE mm

WEIGHT 1350 g

| FRONT (前方) | REAR (後方) | SPUR GEAR (大減齒) 108 T | 64 PITCH | PINION GEAR (啮打齒) 34 T |
|----------------------------|------------|--|----------------------------|------------------------|
| TIRE (齒皮) Teampowers | Teampowers | MOTOR (馬達) Scorpion 10.5t | BATTERY (電池) Orca LCG 6090 | |
| COMPOUND (齒皮膠) 26 | 26 | ESC (電調) Scorpion 160A | SERVO (伺服器) Sawma LH2 | |
| INSERT (齒皮膠) STD | STD | BODY (車殼) Zoo Racing | WING (風翼) Std | |
| WHEEL (輪胎) STD | STD | FINAL DRIVE RATIO (齒比) [SPUR / PINION 41.9]:1 = 6.03 | | |
| TIRE TREATMENT (齒水) SK 1+2 | SK 1+2 | | | |

COMMENT: