

# YZF2

## SETTING SHEET Ver.02

CIRCUIT EOS Rd2 HUDY ARENA

- INDOOR ○ OUTDOOR
- WET ● DRY ○ DUSTY ○ OTHER
- LOW TRACTION ○ MED TRACTION ● HIGH TRACTION
- SMOOTH ○ BUMPY ○ BLUE GROOVE ○ ASTROTURF
- CARPET ○ WOOD

DRIVER Lee Martin DATE 2015/11/21

### FRONT

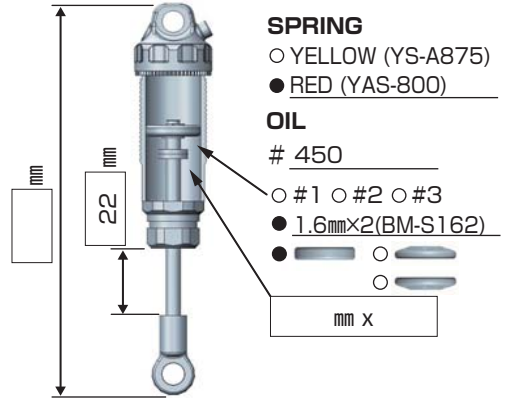
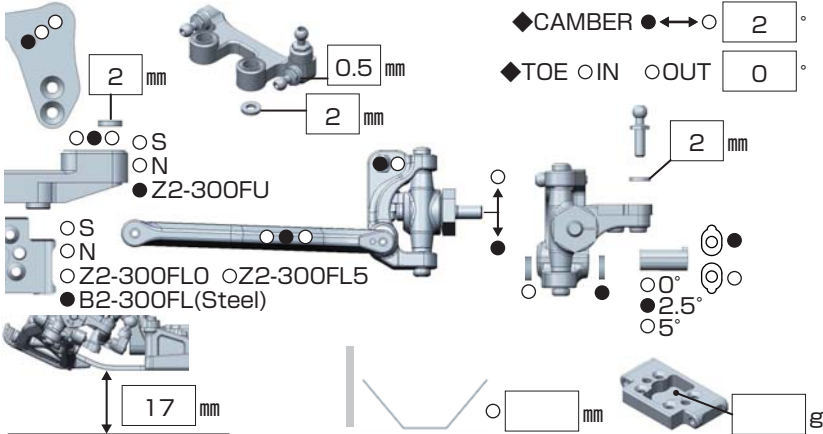

### REAR

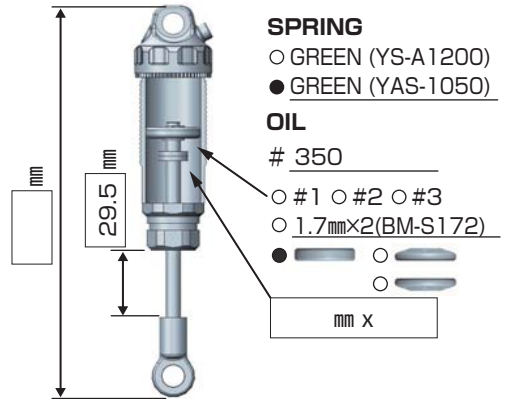
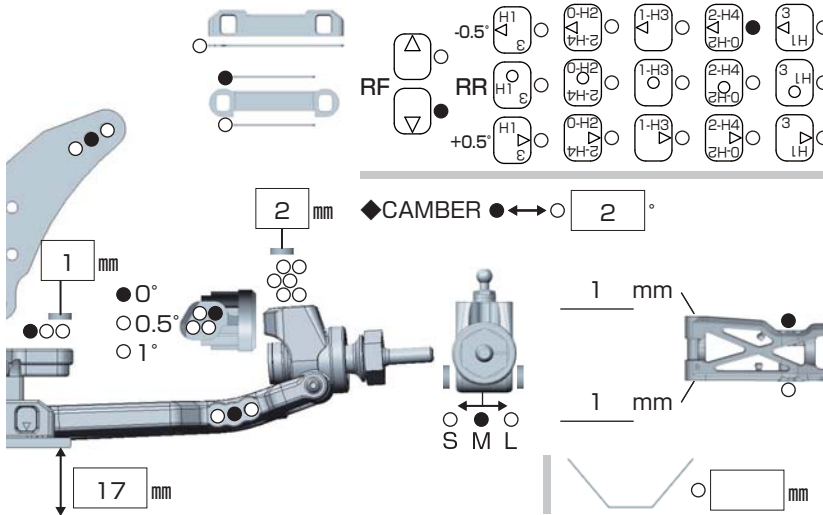

### DRIVE



- MOTOR ⇨ Much more 6.5T  Bonded  Sintered \_\_\_\_\_ mm  
 GEAR ⇨ Spur 80 T / Pinion 22 T : 2.6  
 BATTERY ⇨ ProTek RC shorty  
 ESC ○ Racing Performer X Series  
 ● Much more

#### Battery placement

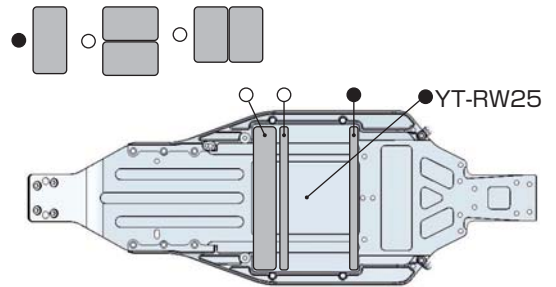

### TIRE

- |              |  |             |  |
|--------------|--|-------------|--|
| <b>FRONT</b> | <b>TIRE</b> ⇨ Schumacher cut stagger _____ | <b>REAR</b> | <b>TIRE</b> ⇨ Schumacher Mini pin _____  |
|              | <b>INSERTS</b> ⇨ None _____                |             | <b>INSERTS</b> ⇨ Schumacher medium _____ |
|              | <b>WHEELS</b> ⇨ Schumacher _____           |             | <b>WHEELS</b> ⇨ Schumacher _____         |

### OTHER

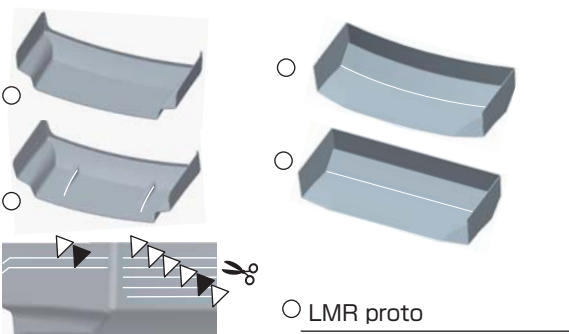

#### COMMENT

Steering ackerman ball stud use short neck, B4-008R, B2-010RB, Z2-008GF, Z2-413G, Z2-101L, Z2-415R00, Z2-S2SD, Z2-S2LD, Z2-670VP, BM-S162, BM-S172, Z2-TSS, Z2-TBS, YS-8BH, Z2-110, LMR large under the battery wight, 5.0mm front wheel hex(B4-011R)