

YZ4F2 DTM

SETTING SHEET Ver.01

CIRCUIT *P&T Hobbies and Raceway, Indiana, USA*

- INDOOR OUTDOOR
- WET DRY DUSTY SMOOTH BUMPY OTHER
- LOW TRACTION MED TRACTION HIGH TRACTION
- CLAY GRASS BLUE GROOVE ASTROTURF DIRT
- CARPET WOOD *Clay Dirt Mix*

DRIVER *Jared Kirkwood*

DATE *2018.02.10*

FRONT

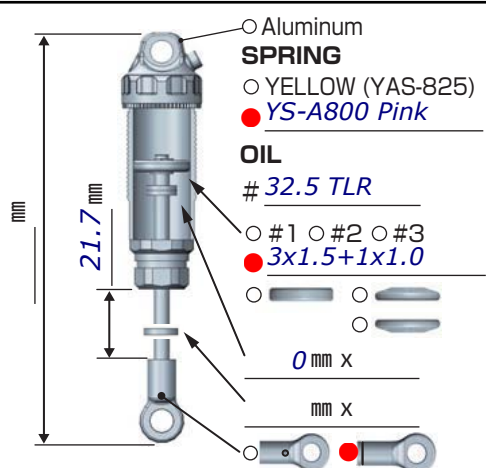
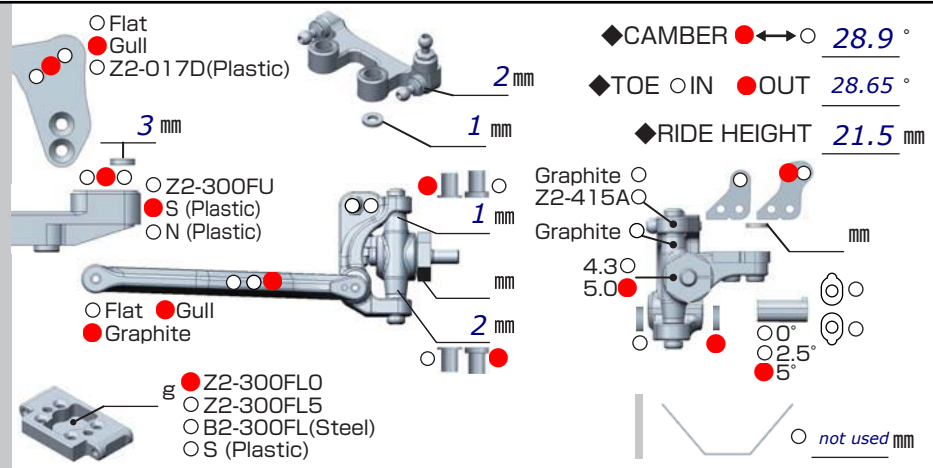

REAR

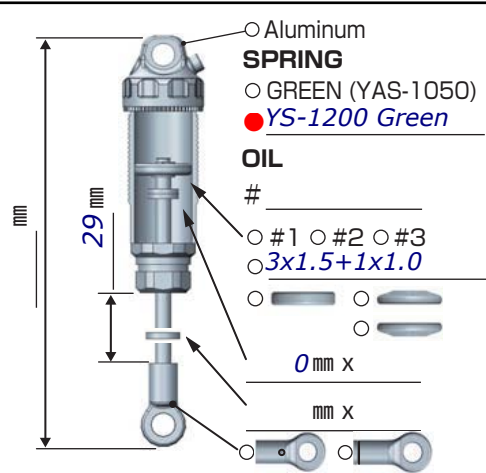
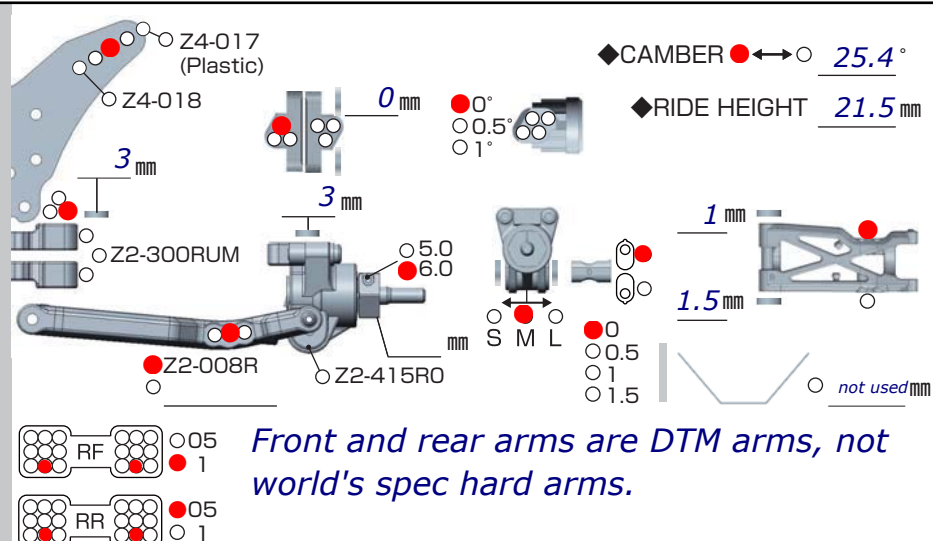

DRIVE

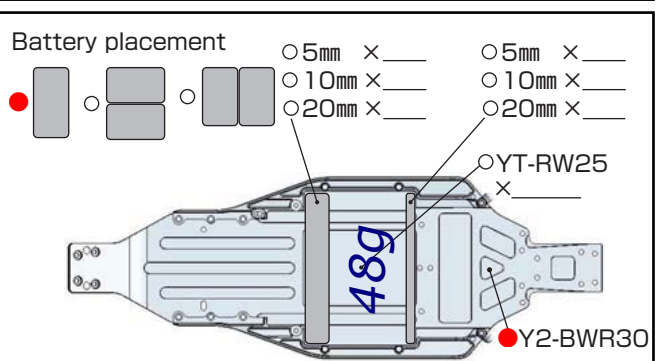
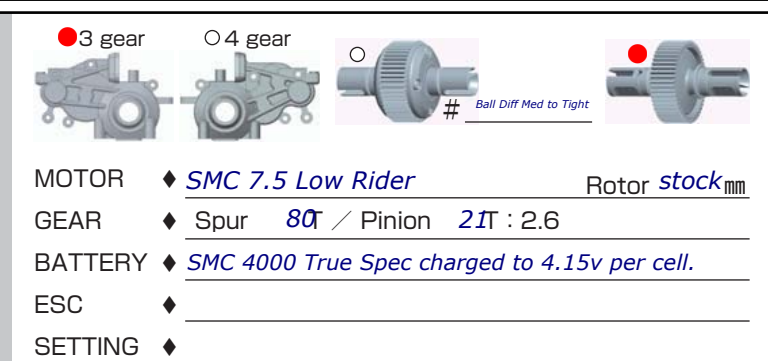

TIRE

FRONT	REAR
TIRE ◆ <i>AKA Ultra Soft Typo + FDJ Yellow</i>	TIRE ◆ <i>AKA Ultra Soft Crosslink + FDJ Yellow</i>
INSERTS ◆ <i>AKA Black 2.4</i>	INSERTS ◆ <i>AKA Red, Punched 2 hole per spoke</i>
WHEELS ◆ <i>AKA Evo 2.4, 2 hole punched 4mm</i>	WHEELS ◆ <i>AKA Hexlight 2.2, 4 hole punched @ 2mm</i>

OTHER

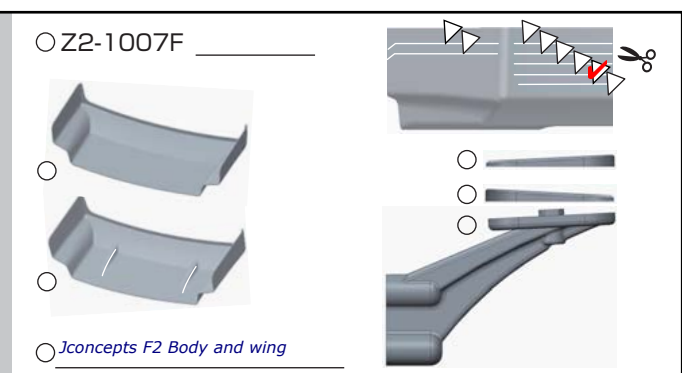

*Camber links are measured in mm.
 battery against waterfall, ESC & Rx mounted against battery.
 Shortest shock eyelet in rear
 Avid RC CPD Slipper Pads on 2 pad slipper.
 World's spec parts unless noted.
 Sauce whipped to dry after 10 minutes of soak.
 20mm servo horn. Front wing mounted low.*