

# YZ-2 DTM2 CAL2

## SETTING SHEET Ver.01

**CIRCUIT** OCRC RACEWAY- JCONCEPTS STOCK NATIONALS

- INDOOR ○ OUTDOOR
- DIRT ○ ASTROTURF ○ CARPET ○ GLASS ○ WOOD
- WET ● DRY ● DUSTY ● SMOOTH ○ BUMPY
- HARD PACKED ● CLAY ○ BLUE GROOVE ○
- LOW TRACTION ○ MED TRACTION ○ HIGH TRACTION

**DRIVER** JAKE THAYER

**DATE** 5/2019

### FRONT

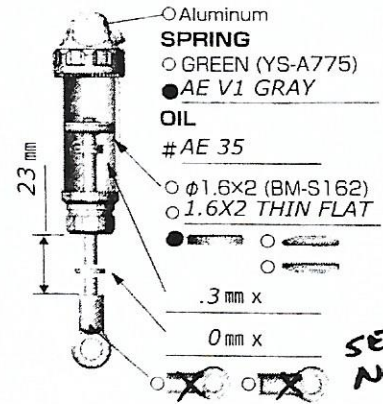
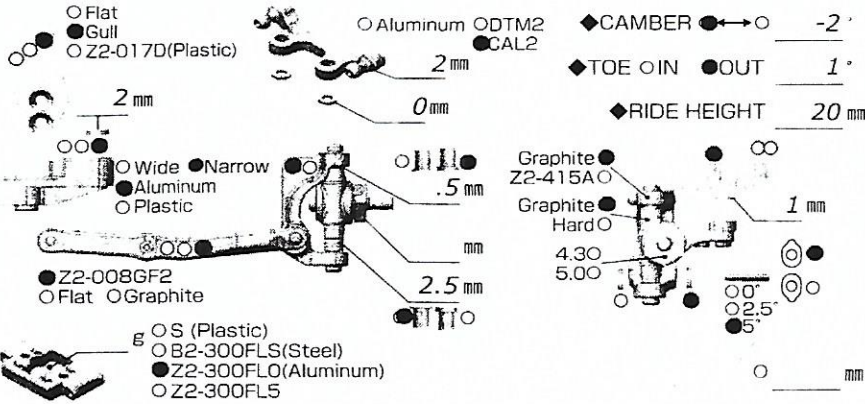

### REAR

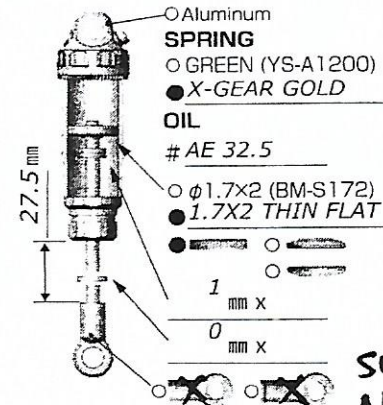
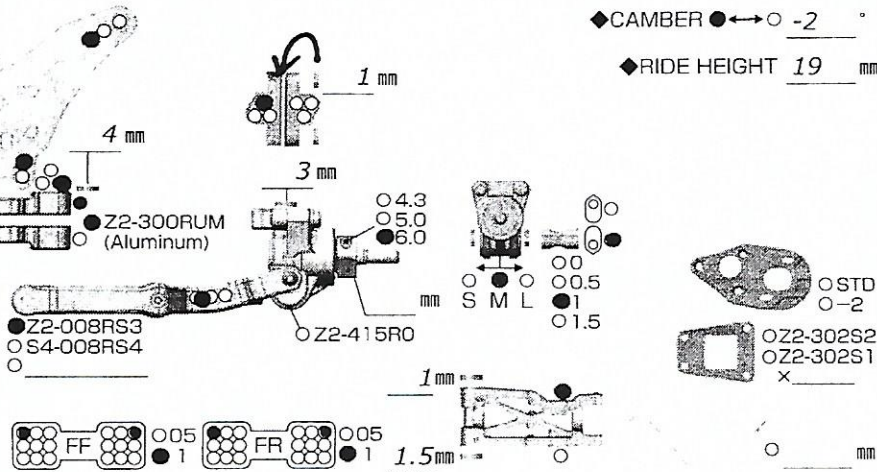

### DRIVE

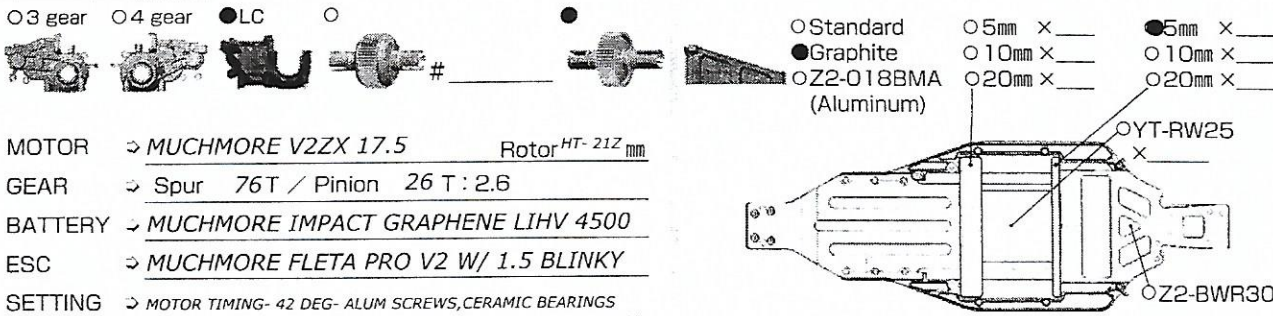

### TIRE

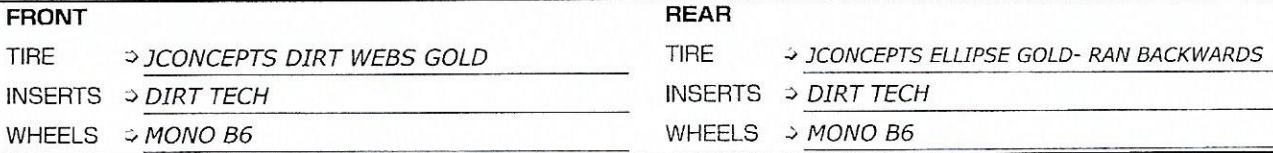

### OTHER

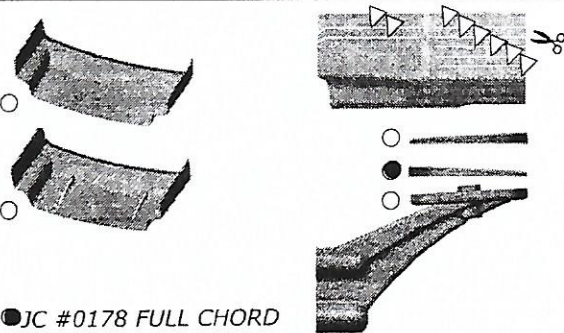

- Z2-302TLC TRANS CASE, PROTOTYPE REAR TOWER UTILIZING YZ-2T FRONT SHOCKS (27.5MM BODIES) + 2 DIFF HEIGHT
- SD-008RC LONGEST SHOCK END IN FRONT(HAVE TO GRIND OFF FLANGE) WITH SHORTEST SHOCK END IN REAR (KIT, NO DOT)
- YZ-2T SIDE GUARDS, FRONT BULKHEAD, BATT MOUNTING SYSTEM- BATTERY POSITION FORWARD HOLE ON SIDE GUARD, MIDDLE HOLE ON MOUNT(5-6MM OFF OF WATERFALL)
- Z2-200NT PLASTIC STEERING RACK W/ SHORT BELLCRANKS, 3 DOT STEERING ARMS
- 5.5MM FRONT HEXES (TLR #2930)
- JC FIN TI TURNBUCKLES, YOKOMO TI SCREW KIT, ALUM FRONT AXLES
- MOD 13.5 PIN DRIVE SYSTEM(TLR SYSTEM W/YOKOMO YOKES ON BONES, PART#18843), 1UP RED CVA OIL (1 DROP IN EACH CVA, CLEANED AND RE-LUBED DAILY)
- SCHELLE NOVA SLIPPER, WHITE/WHITE/RED PADS
- JC #0157 LOW FRONT WING W/ YOKOMO MOUNT, #0178 REAR WING, F2 LW BODY
- 63G UNDER BATTERY
- RUNNING WEIGHT 1540G