

B-MAX2

SETTING SHEET Ver.01

CIRCUIT

- INDOOR OUTDOOR
- WET DRY DUSTY OTHER
- LOW TRACTION MED TRACTION HIGH TRACTION
- SMOOTH BUMPY BLUE GROOVE ASTROTURF

DRIVER _____

DATE / /

FRONT

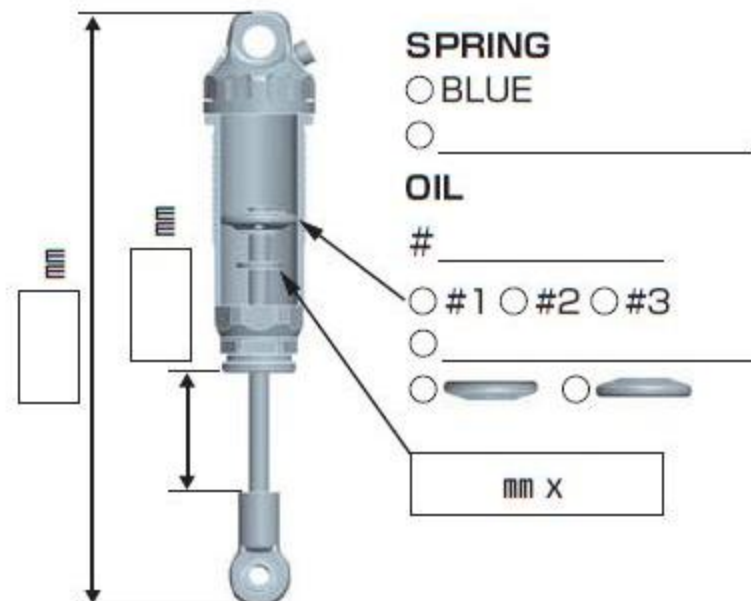
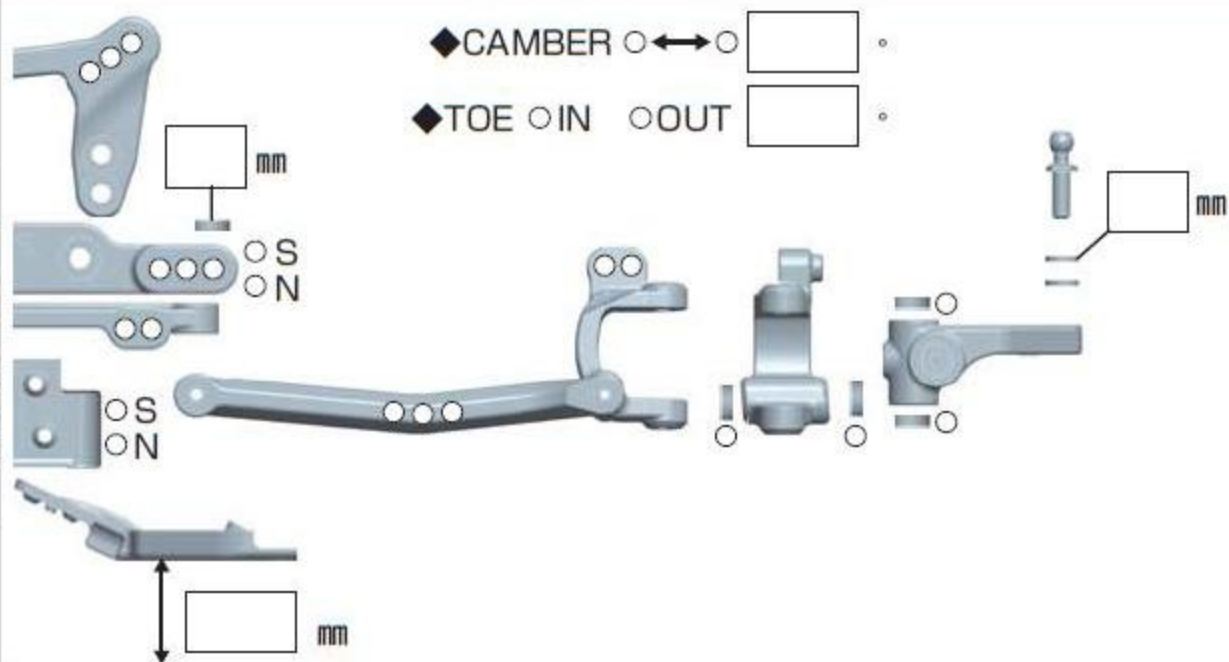

REAR

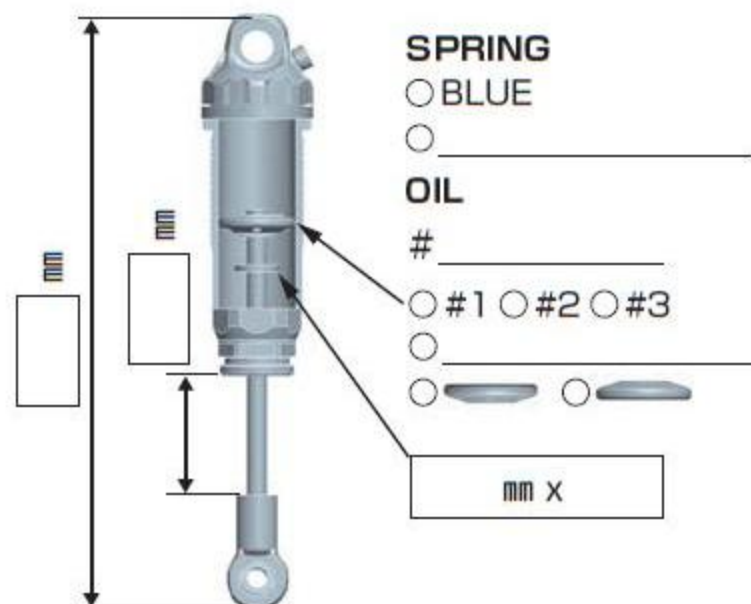
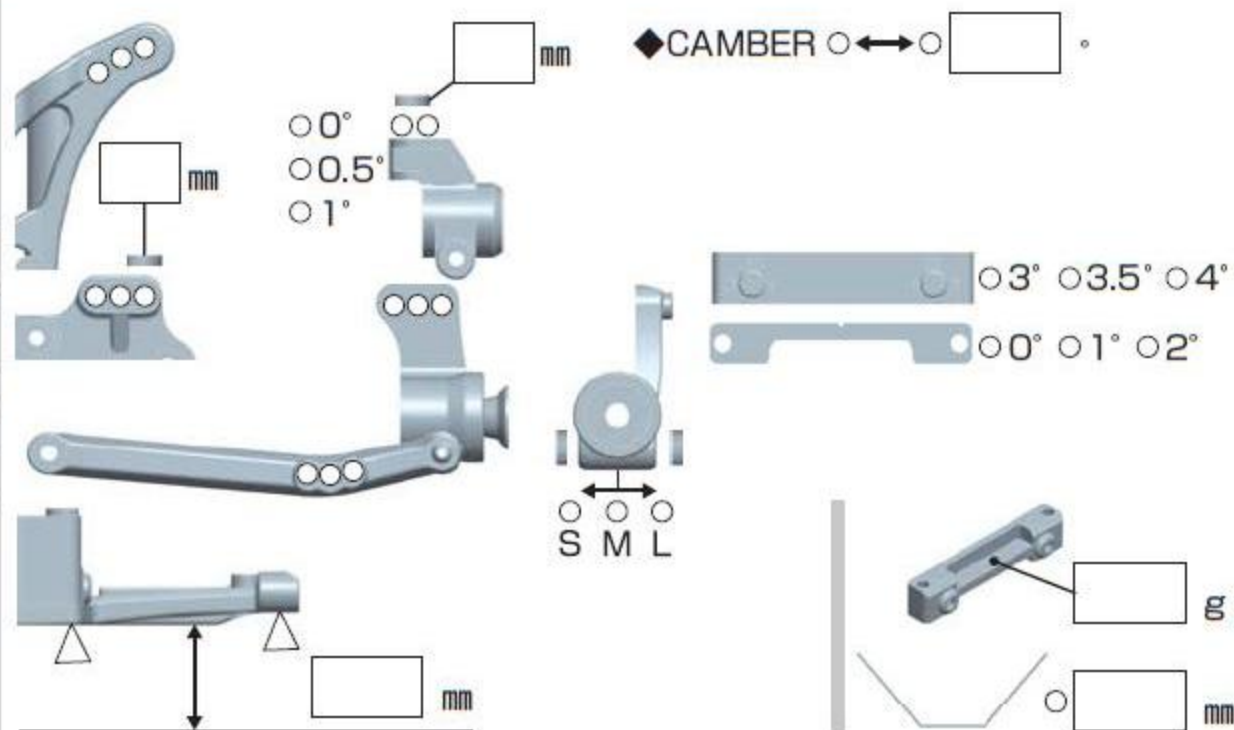

DRIVE

- MOTOR _____ Bonded Sintered mm
- GEAR Spur T / Pinion T : 2.6
- BATTERY _____
- ESC NOSRAM / / /
- _____

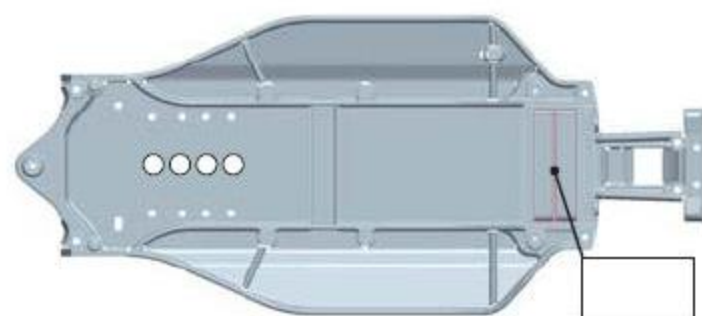

TIRE

- | | |
|-------------------------------------|-------------------------------------|
| FRONT | REAR |
| TIRE <input type="radio"/> _____ | TIRE <input type="radio"/> _____ |
| INSERTS <input type="radio"/> _____ | INSERTS <input type="radio"/> _____ |
| WHEELS <input type="radio"/> _____ | WHEELS <input type="radio"/> _____ |

OTHER

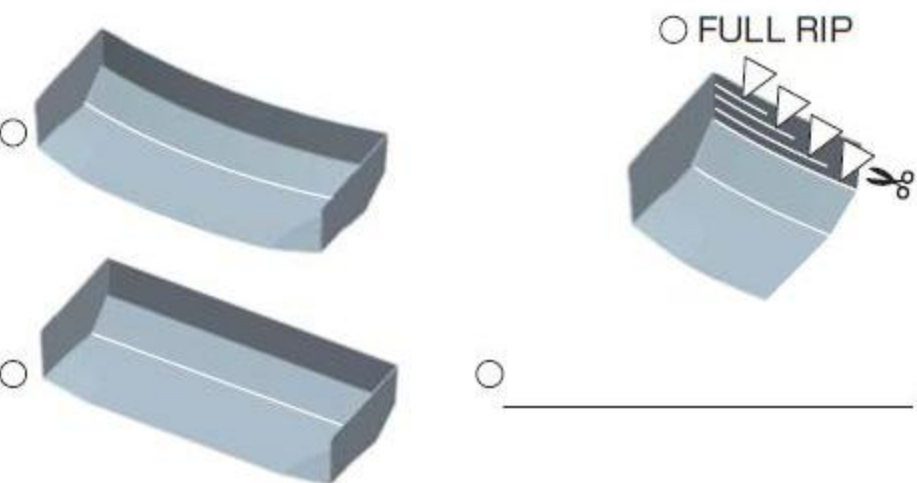

COMMENT
