

FACTORY X-6³ Setup sheet

Arm0 - V1.0

Driver: Mark Samuelson Date: Aug 21 2013
 Event: _____
 Track: Thunder Alley RC, Wilson NC

Track Condition

Composition: Astroturf Blue Groove Carpet Clay Dirt Grass Other: _____
 Layout: Open Tight Surface: Bumpy Smooth Grip: Low Medium High

Front Suspension

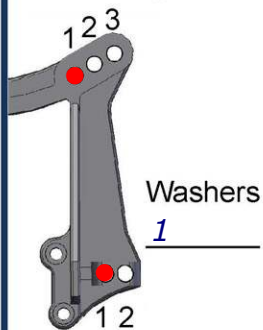

Toe: _____ 0° Axles: Trailing Inline
 Camber: _____ -0.5° Caster Block: 20° 25° 30°
 Ride Height: Arms level Ackermann: Forward Back

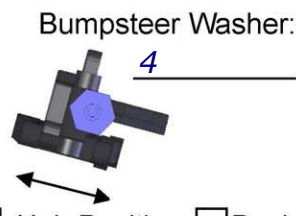
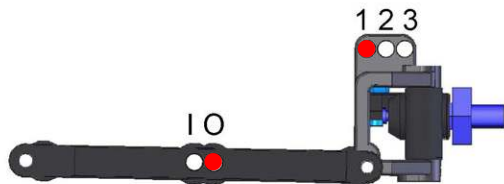

Bumpsteer Washer: 4
 Forward Hub Position Back

Front Shocks

Brand: AE Big Bore
 Spring: Avid Red
 Piston: 1.5 x 2 + 1.1 x 2
 Oil: 30 Emulsion: Yes No
 Limiters: 3

Front Tires

Tire: Jconcepts ribs
 Insert: stock
 Wheels: DE Racing

Rear Suspension

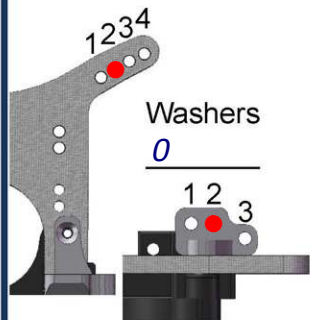

Camber: _____ -1°
 Ride Height: Bones level
 Transmission Height: .030
 Swaybar: none

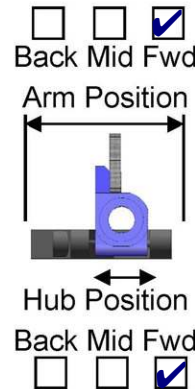
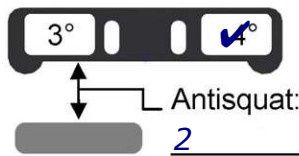
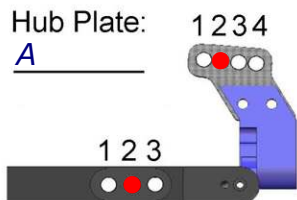

Hub Plate: A

Antisquat: 2

Hub Position: Back Mid Fwd

Rear Shocks

Brand: AE Big Bore
 Spring: Avid Yello
 Piston: 1.5 x 2 + 1.1 x 2
 Oil: 27.5 Emulsion: Yes No
 Limiters: 2

Rear Tires

Tire: Proline Holeshot
 Insert: stock
 Wheels: DE Racing

Weighs:

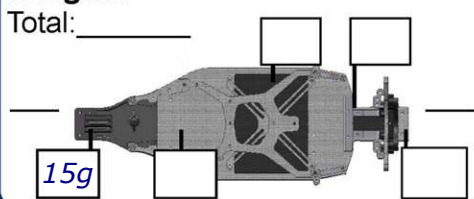

Comments:

*UpGrade RC Vortex wing, battery spaced 3/4 to the rear.
 Wing as far down as possible. 0 degree hubs rear. 25
 degree caster block dremmeled so it sits forward more.
 Speedydad front CF tower*

Battery: Venom 3800 Shorty
 Motor: Tekin Redline Gen2 7.5
 Gearing: 81/22
 ESC: Tekin RS
 ESC Settings: _____