

Name: _____ Date: _____ Event: _____

Track Conditions: Outdoor Indoor Wet Dry High Bite Low Bite
 Rough Smooth Hard Packed Loose/Loamy Blue Groove

Bumpsteer/Ackerman/Servo Saver:

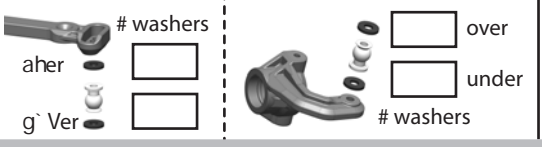

Front End:

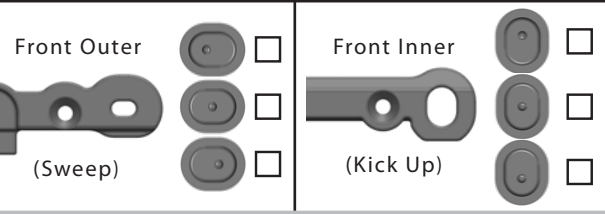
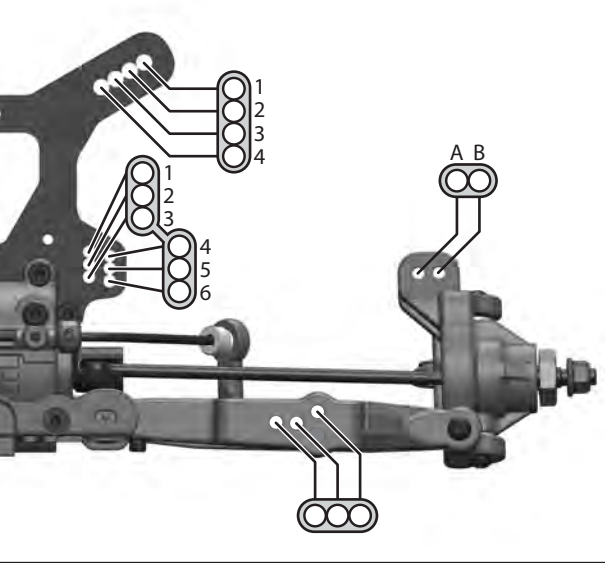

Rear End:

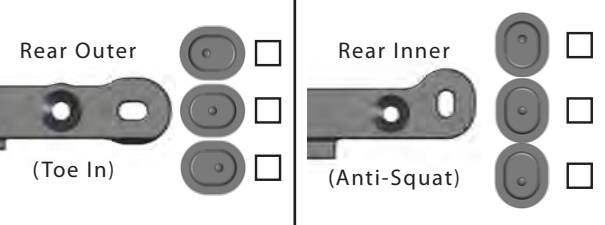
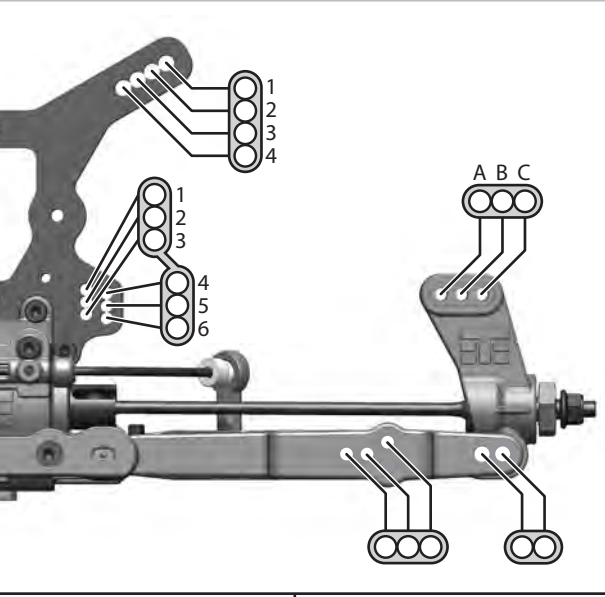

Suspension:

	FRONT	REAR
RIDE HEIGHT		
CAMBER		
TOE (in/out)		
SWAY BAR		
SHOCK LENGTH (DROOP)		

Body/Mounts:

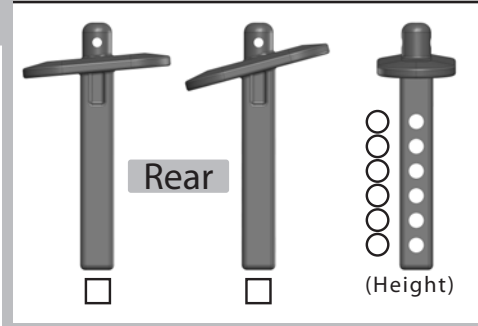
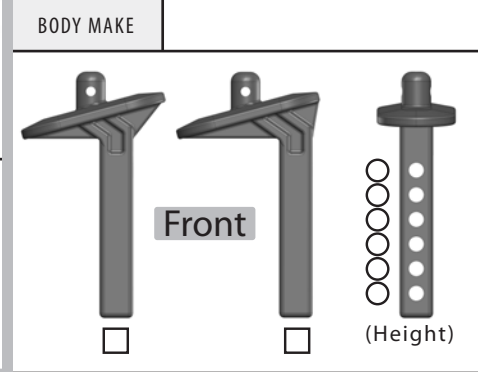

Wheelbase:

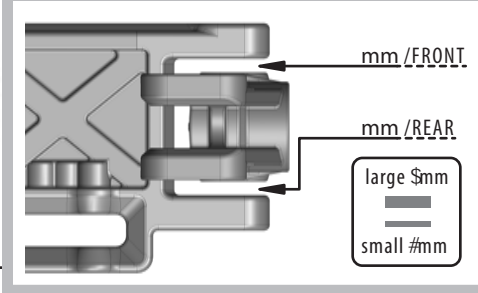

Notes:

Shocks:

	FRONT	REAR
OIL		
PISTON		
SPRING		
REBOUND	%	%
STD/EMUL/VENT		

Tires / Wheels:

	FRONT	REAR
BRAND/TREAD		
COMPOUND		
INSERT		
WHEEL		

NOTES:

Differential Oil:

FRONT	CENTER	REAR

Electronics:

ESC: _____
 Battery: _____
 Motor: _____
 Radio: _____
 Servo: _____

Drivetrain:

SPUR GEAR Metal Composite
 Traktion Drive Elektri-Clutch Pinion
 PINION SIZE _____ (teeth)
 Mechanical Brakes Motor Brakes

Chassis Braces:

Front Middle Rear
 (front brace is always recommended)