

Name: _____ Date: _____ Event: _____

Track: Indoor Outdoor Size: Small Medium Large Traction: Low Med High

Surface: Smooth Bumpy Rutted Type: Loose/Loamy Hard Pack Blue Groove Clay

Bumpsteer/Ackerman/Servo Saver: _____ Condition: Dusty Dry Wet Muddy

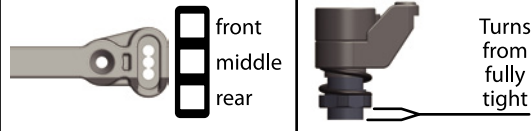

Shocks:

	FRONT	REAR
OIL		
BRAND		
PISTON		
SPRING		
REBOUND	%	%
STD/EMUL/VENT		

Front End:

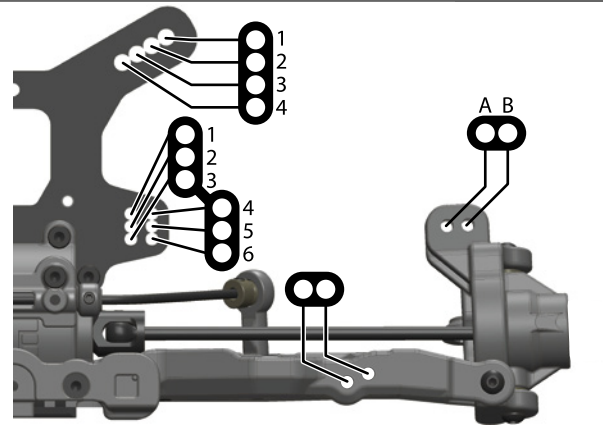

Suspension:

	FRONT	REAR
RIDE HEIGHT		
CAMBER		
SWEEP		
KICK UP		
ANTI-SQUAT		
TOE (in/out)		
SWAY BAR		
SHOCK LENGTH (DROOP)		

Tires/Wheels:

	FRONT	REAR
BRAND/TREAD		
COMPOUND		
INSERT		
WHEEL		



Body/Mounts:

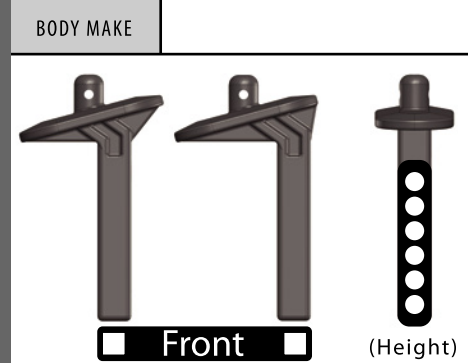

Differential Oil:

FRONT	CENTER	REAR

Rear End:

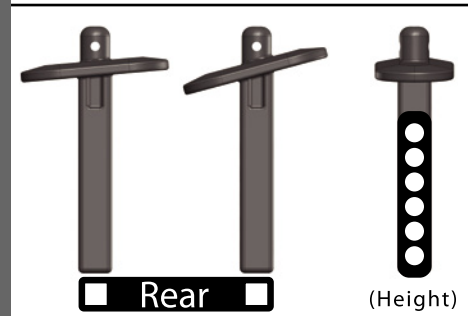
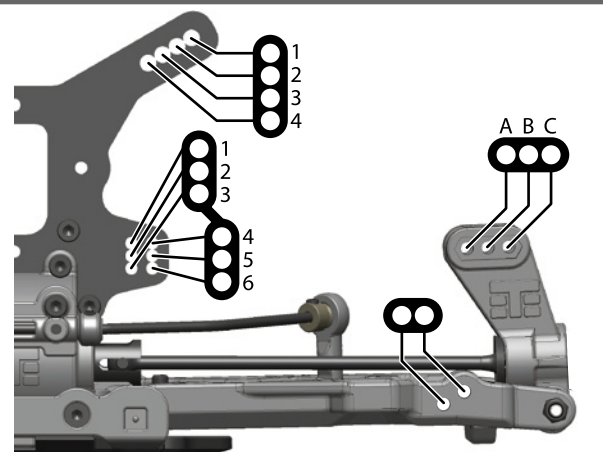

Electronics:

ESC:	
Battery:	
Motor:	
Radio:	
Servo:	



Wheelbase:

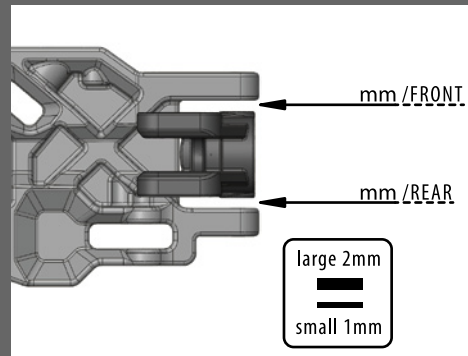

Drivetrain:

PINION SIZE	(teeth)
-------------	---------

Chassis Braces:

Front <input type="checkbox"/>	Middle <input type="checkbox"/>	Rear <input type="checkbox"/>
(front brace is always recommended)		

Notes:

