



BUILDING
INSTRUCTIONS



INTRODUCTION



Thank you for purchasing the Tekno RC NT48.3 1/8th 4WD Nitro Competition Truggy. The NT48.3 represents the state-of-the-art in 1/8th nitro truggy technology. We hope you have as much fun driving your new vehicle as we did developing it. We are always working on new projects, so please check our website (www.teknorc.com) regularly for the latest news, parts, and kits. Thanks again.

Additional equipment and parts needed:

- 2/3 channel surface radio transmitter and receiver
- High torque steering and brake servo (at least 300 oz/in)
- RX battery, switch harness
- .21 nitro engine, tuned pipe, manifold, and glow plug
- Fuel bottle, fuel, 1/8th starter box, and glow ignitor
- 1/8th scale truggy tires, wheels & CA glue
- Paint for body

Tools needed:

- Hex drivers 1.5mm (TKR1104), 2.0mm (TKR1105), 2.5mm (TKR1106)
- Nut drivers 5.0mm (TKR1107), 5.5mm (TKR1108), 7.0mm (TKR1109)
- 17mm Wheel Wrench (TKR1116)
- Pivot Ball and Shock Multi-tool (TKR1115, for shock assembly)
- 4mm and 5mm turnbuckle wrench (TKR1103)
- Hobby knife
- Needle-nose pliers
- 4mm arm reamer
- Lexan Body Scissors

Disclaimer: Tekno RC is not responsible or liable for any property or personal damage, loss, or injury incurred as a result of using this product. This kit is meant for use by persons 14 years of age or older and in the strict confines of a legally permitted RC track or facility.

Warnings: Always double-check that your radio gear is working properly before operating vehicle. Never operate the vehicle indoors (unless the RC track is an indoor facility). Use caution while operating vehicle so as not to collide with people who may be turn marshalling or who might otherwise not be aware that a fast moving RC vehicle is in the vicinity.

Warranty: We warrant that the parts included in this kit are free from defects. If you find a defective part in your kit, please contact us @ info@teknorc.com and we will help you to resolve the issue. We do not warranty parts that may be broken during operation of the vehicle or otherwise. Refer to the end of this instruction manual for a listing of spare/replacement and option parts. All spare parts and other info are available on our website (www.teknorc.com) and through our network of domestic and international dealers and distributors.

BAG A

FRONT DIFFERENTIAL (OVERVIEW)

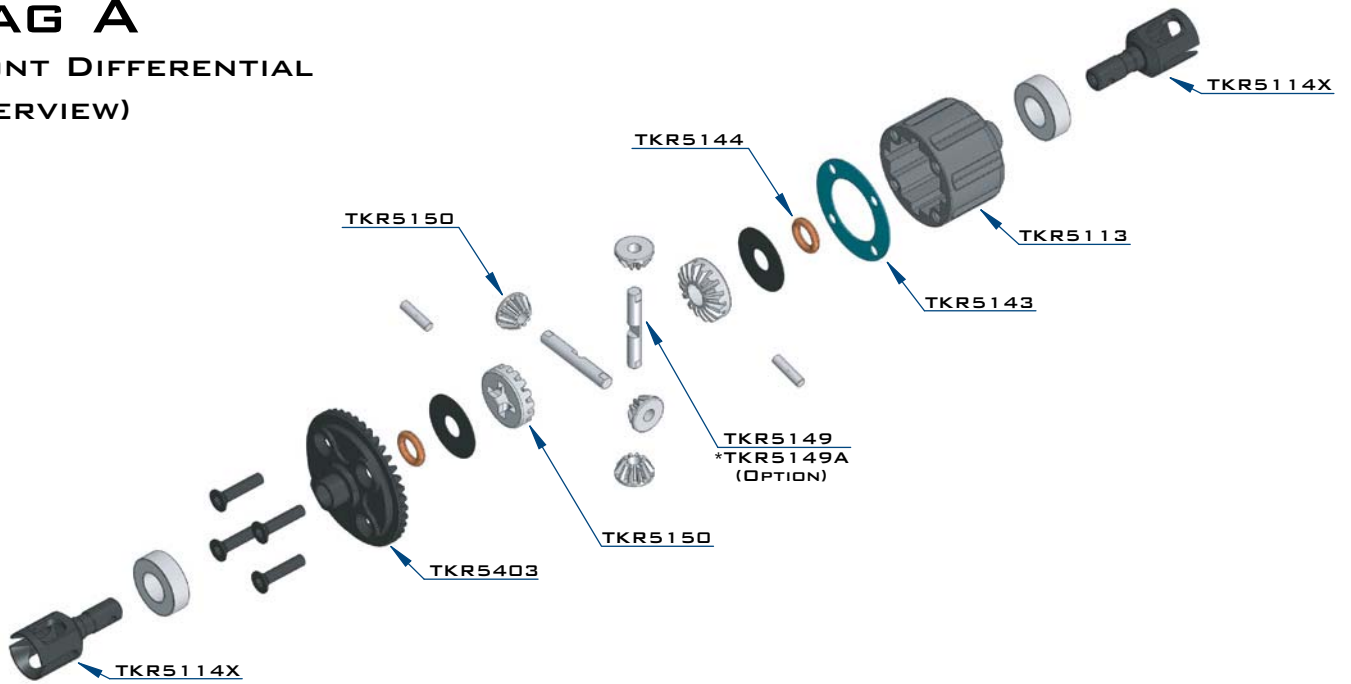

STEP A-1

Apply grease to the groove where the o-ring is placed as well as the o-ring itself

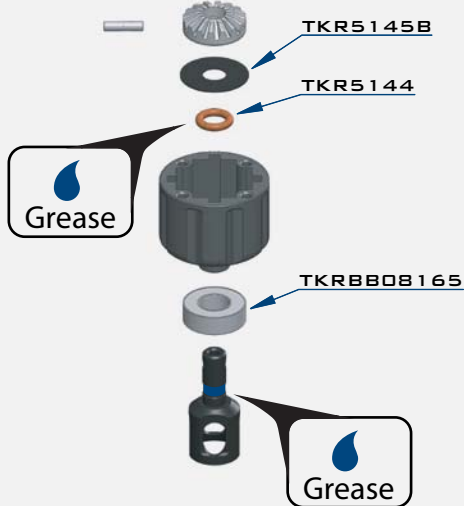

STEP A-2

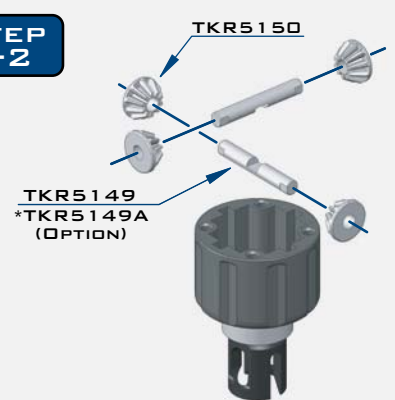

STEP A-4

Apply a liberal amount of grease in the areas between the shims and o-rings, as well as around the outdrive and both sides of the seal

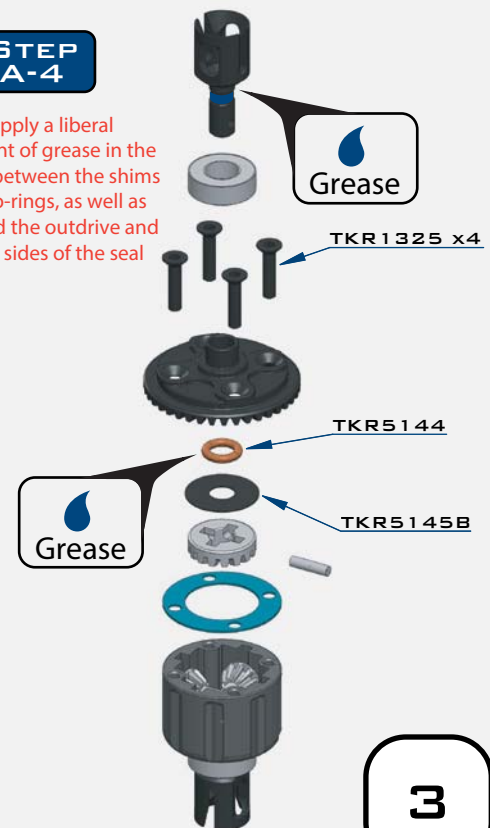

STEP A-3



Fill with 10,000 wt oil to 1mm below full
DO NOT OVER FILL

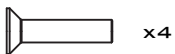

TKR1325
M3X14MM FLAT HEAD SCREW



TKR5144
DIFFERENTIAL O-RINGS

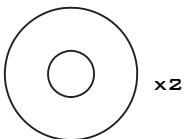

TKR5145B
DIFFERENTIAL SHIMS (6X17MM)



TKRBB08165
BALL BEARING(8X16X5MM)

BAG B

CENTER DIFFERENTIAL

(OVERVIEW)

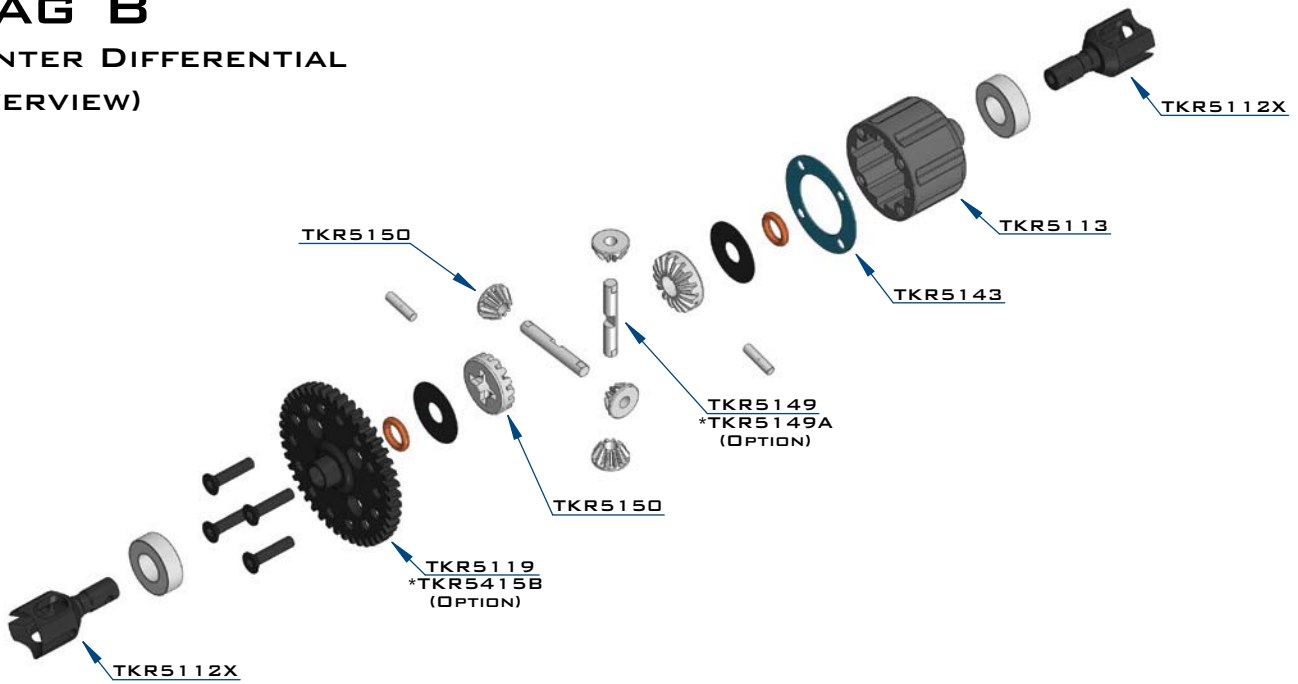

STEP B-1

Apply grease to the groove where the o-ring is placed as well as the o-ring itself

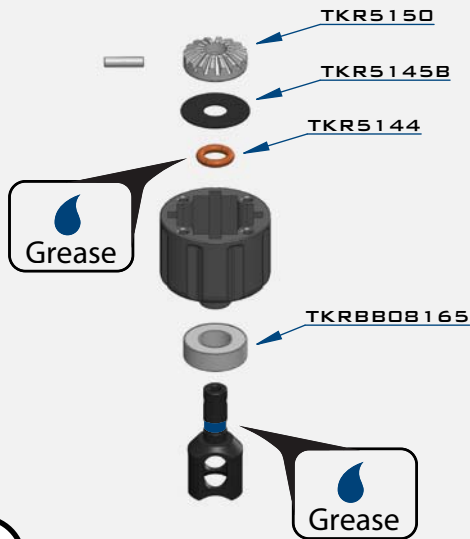

STEP B-2

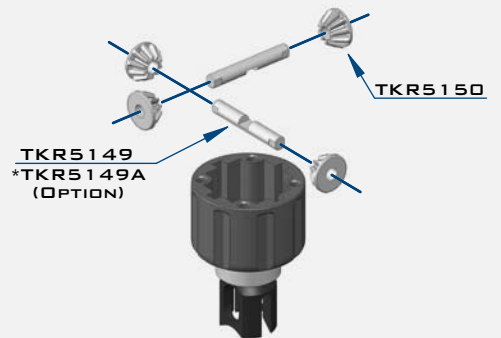

STEP B-4

Apply a liberal amount of grease in the areas between the shims and o-rings, as well as around the outdrive and both sides of the seal

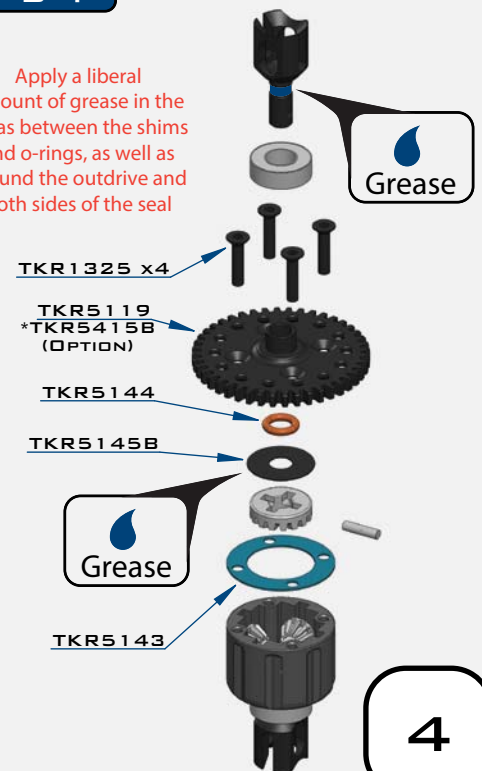

STEP B-3



Fill with 10,000 wt oil to 1mm below full
DO NOT OVER FILL

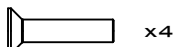

TKR1325
M3X14MM FLAT HEAD SCREW



TKR5144
DIFFERENTIAL O-RINGS

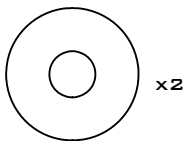

TKR5145B
DIFFERENTIAL SHIMS (6X17MM)

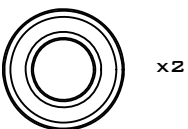

TKRBB08165
BALL BEARING(8X16X5MM)

BAG C

REAR DIFFERENTIAL (OVERVIEW)

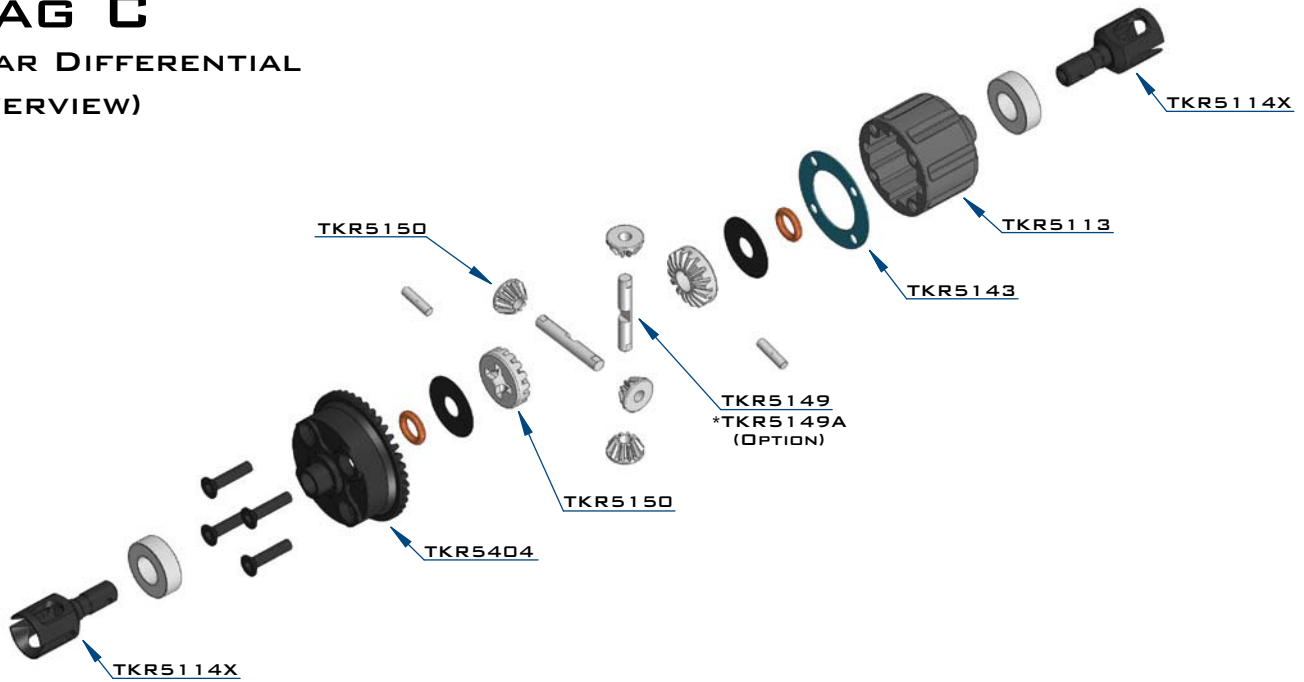

STEP C-1

Apply grease to the groove where the o-ring is placed as well as the o-ring itself

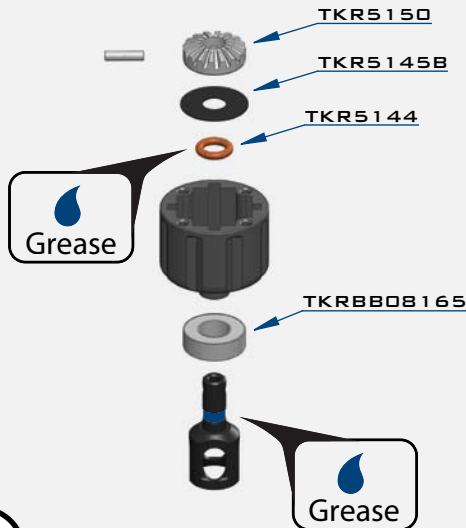

STEP C-2

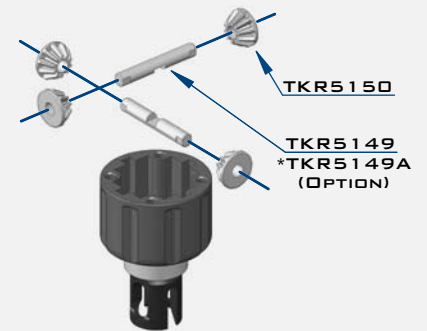

STEP C-4

Apply a liberal amount of grease in the areas between the shims and o-rings, as well as around the outdrive and both sides of the seal

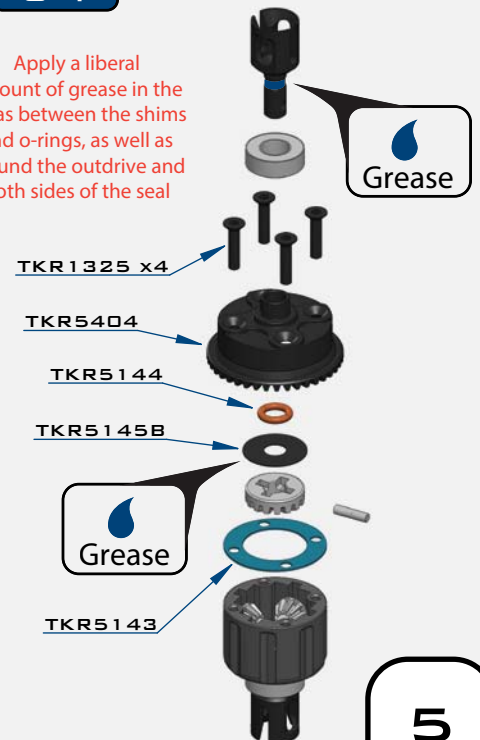

STEP C-3

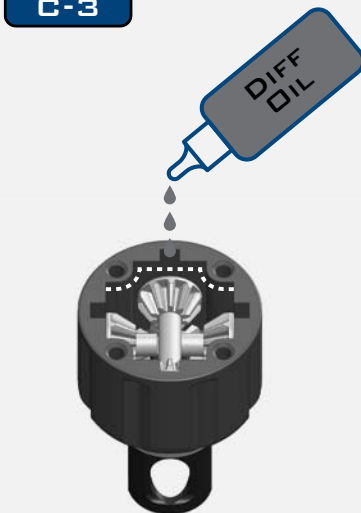

Fill with 5000 wt oil to 1mm below full
DO NOT OVER FILL

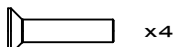

TKR1325
M3X14MM FLAT HEAD SCREW



TKR5144
DIFFERENTIAL O-RINGS

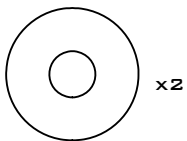

TKR5145B
DIFFERENTIAL SHIMS (6X17MM)

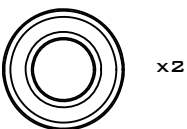

TKRBB08165
BALL BEARING(8X16X5MM)

BAG D

FRONT GEARBOX (OVERVIEW)

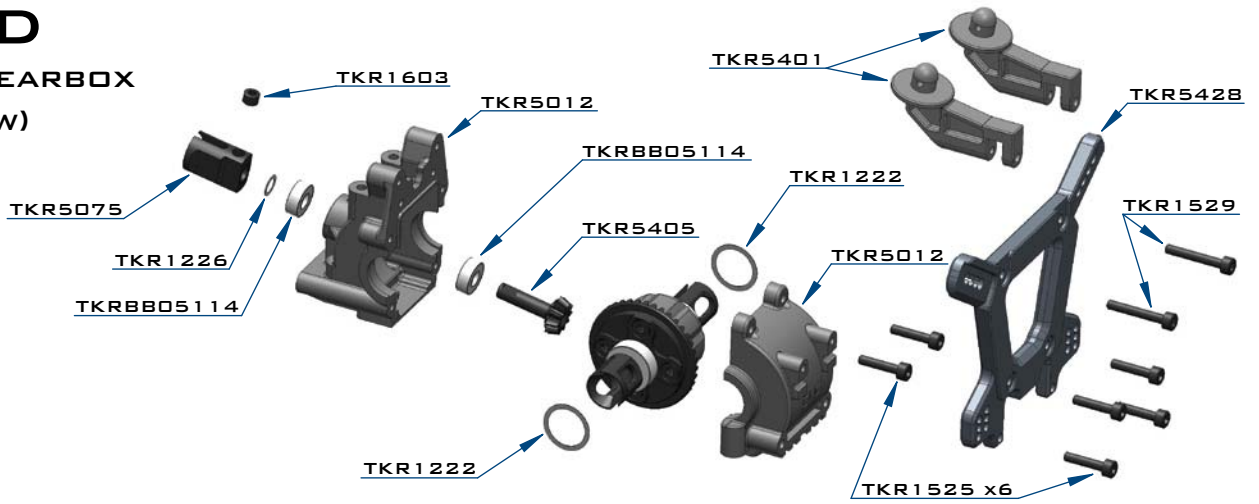

STEP D-1

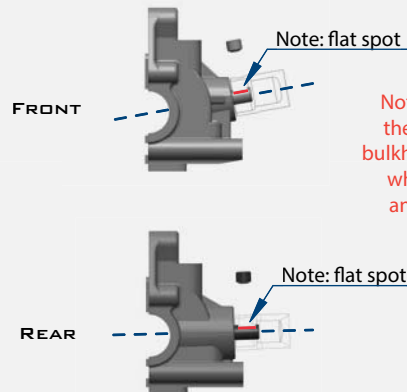
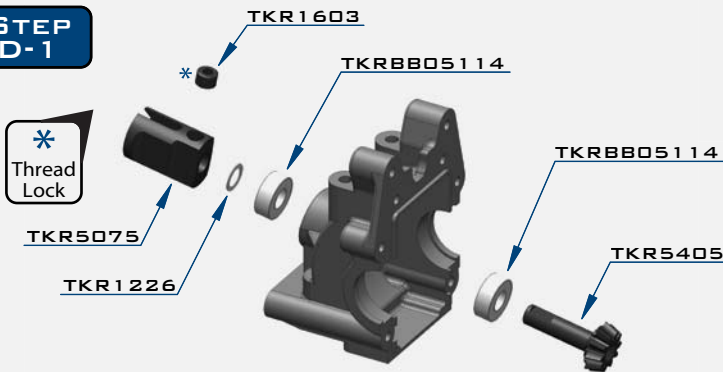

Note: TKR1222 - The gear mesh should be as close as possible without any binding. Test the fitment of the diff with both TKR1222 shims on the gear-side of the diff. If the diff turns freely without binding, continue to next step. If the diff binds and does not turn freely (it will make a grinding or crunching sound when spun), remove one TKR1222 shim from the gear side and install it onto the other side of the diff. Reassemble and test the mesh again. If it is still binding, remove the second TKR1222 shim from the gear side and install it onto the other side of the diff. When you are satisfied that you have the best gear mesh possible continue to the next step.



x2

TKR1222
13x16x0.1MM DIFF SHIM



x1

TKR1226
5x7x0.2MM SHIM

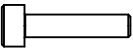

x6

TKR1525
M3x14MM CAP HEAD SCREW

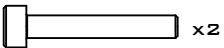

x2

TKR1529
M3x20MM CAP HEAD SCREW



x1

TKR1603
M5x4MM SET SCREW



x2

TKRBB05114
BALL BEARING (5x11x4)

STEP D-2

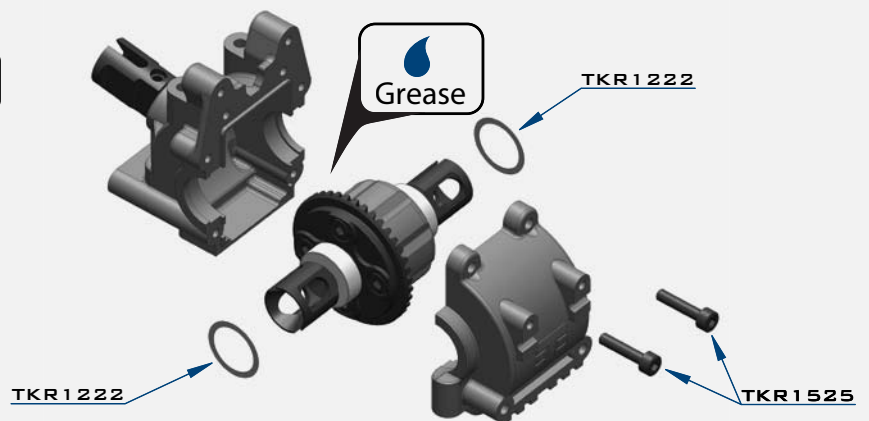

STEP D-3

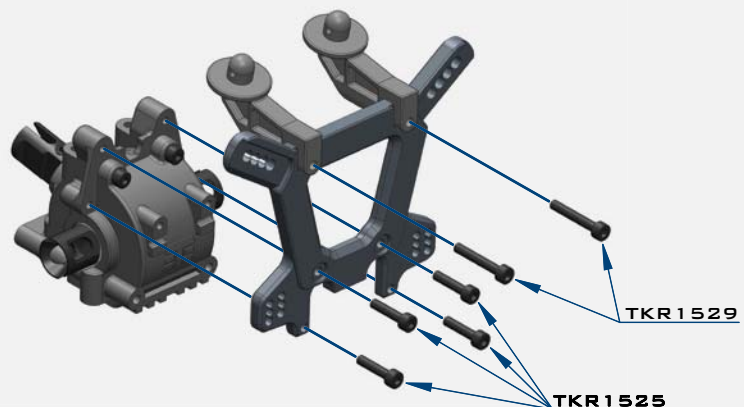

BAG E

CENTER DIFFERENTIAL ASSEMBLY (OVERVIEW)

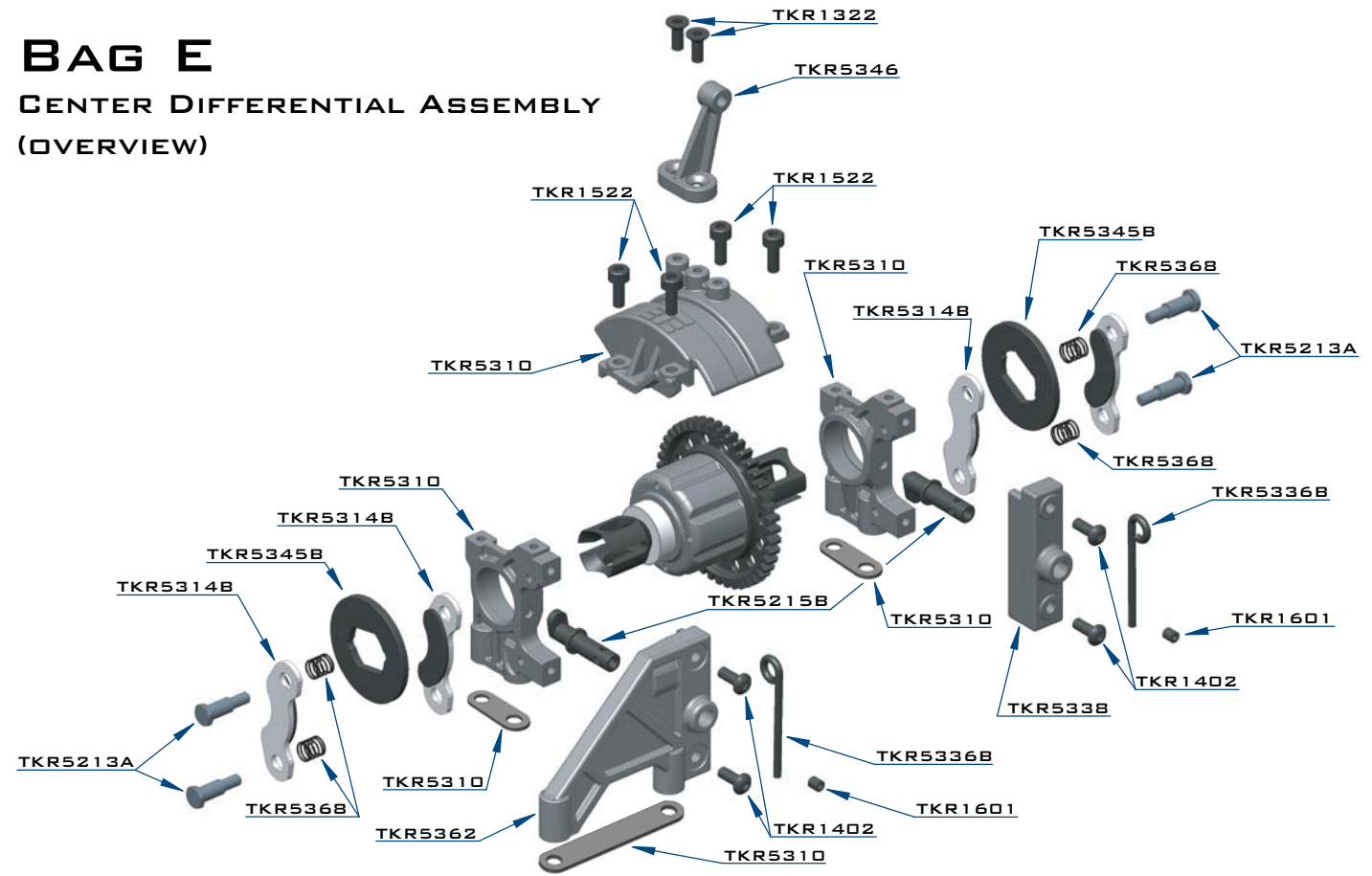

STEP E-1

CA GLUE Note: Use CA glue to attach risers to diff support bottoms

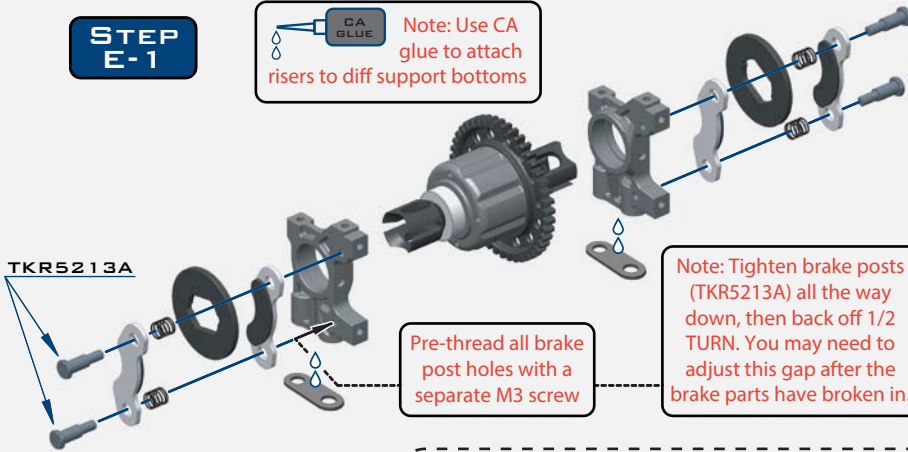

STEP E-2

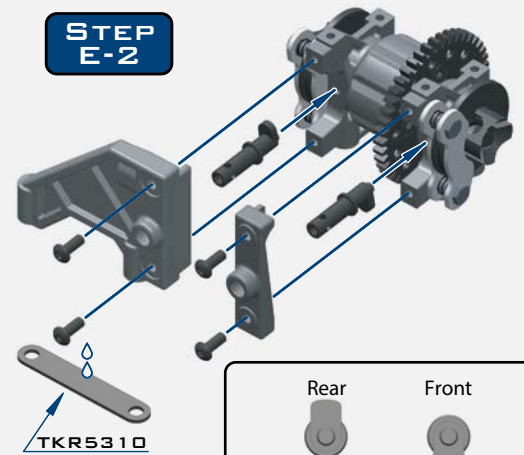

STEP E-3

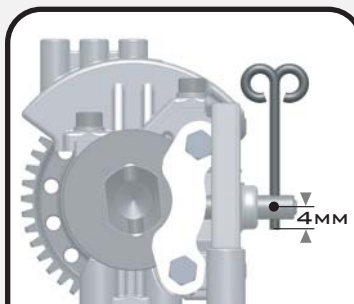
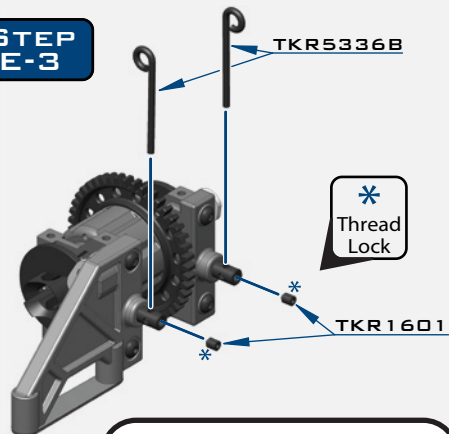

STEP E-4

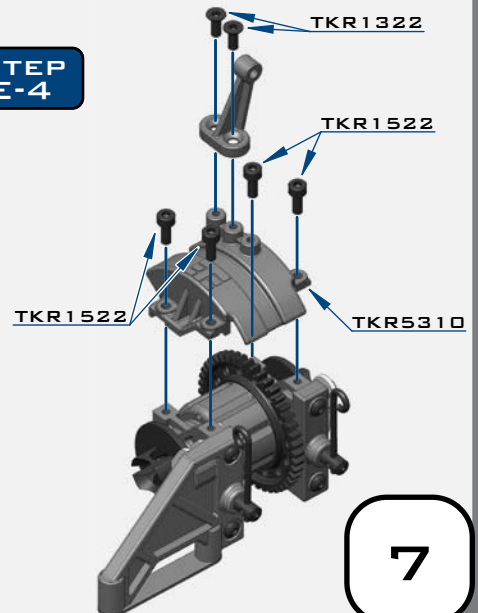

x2
TKR1322
M3x8MM FLAT HEAD SCREW

x4
TKR1402
M3x8MM BUTTON HEAD SCREW

x4
TKR1522
M3x8MM CAP HEAD SCREW

x2
TKR1601
M3x4MM SET SCREW

BAG F

REAR GEARBOX (OVERVIEW)

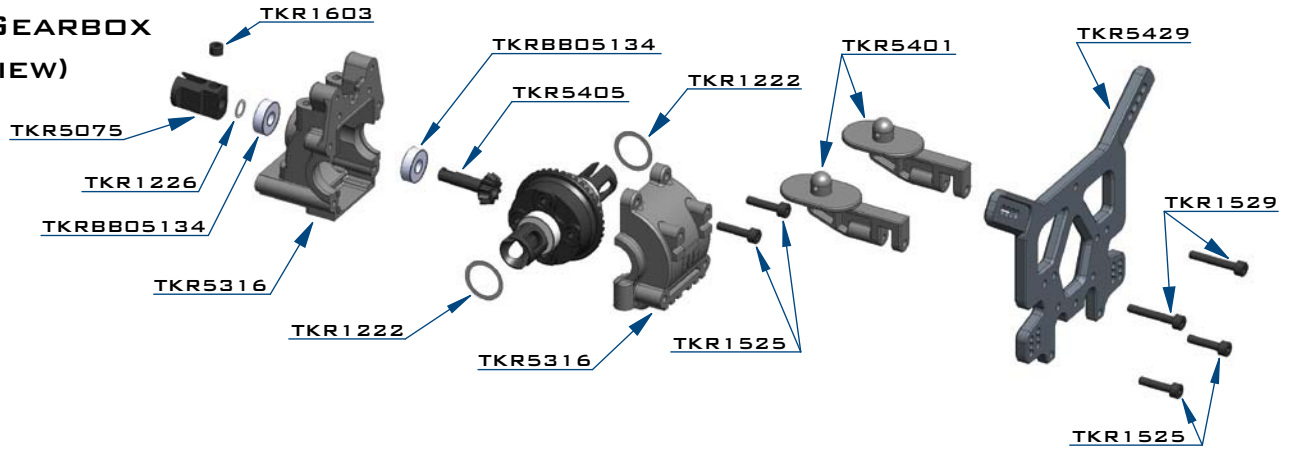

STEP F-1

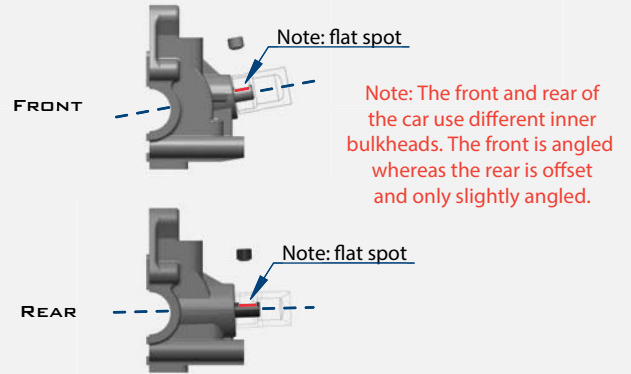
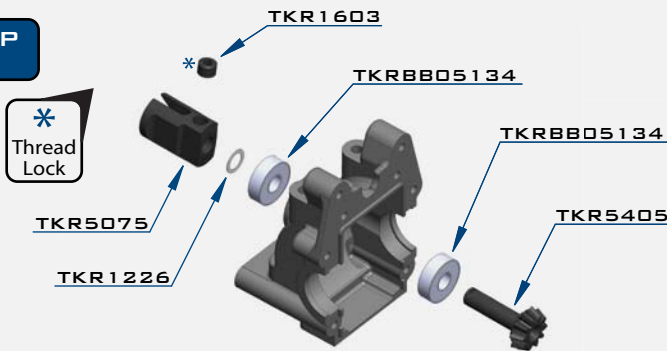

Note: TKR1222 - The gear mesh should be as close as possible without any binding. Test the fitment of the diff with both TKR1222 shims on the gear-side of the diff. If the diff turns freely without binding, continue to next step. If the diff binds and does not turn freely (it will make a grinding or crunching sound when spun), remove one TKR1222 shim from the gear side and install it onto the other side of the diff. Reassemble and test the mesh again. If it is still binding, remove the second TKR1222 shim from the gear side and install it onto the other side of the diff. When you are satisfied that you have the best gear mesh possible continue to the next step.

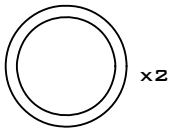

TKR1222
13x16x0.1MM DIFF SHIM

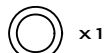

TKR1226
5x7x0.2MM SHIM

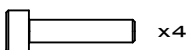

TKR1525
M3x14MM CAP HEAD SCREW

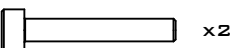

TKR1529
M3x20MM CAP HEAD SCREW



TKR1603
M5x4MM SET SCREW

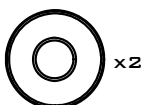

TKRBB05134
BALL BEARING (5x13x4)

STEP F-2

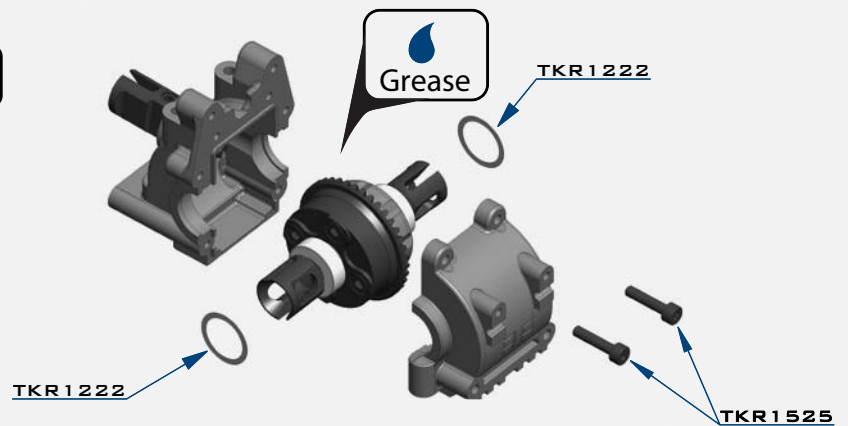

STEP F-3

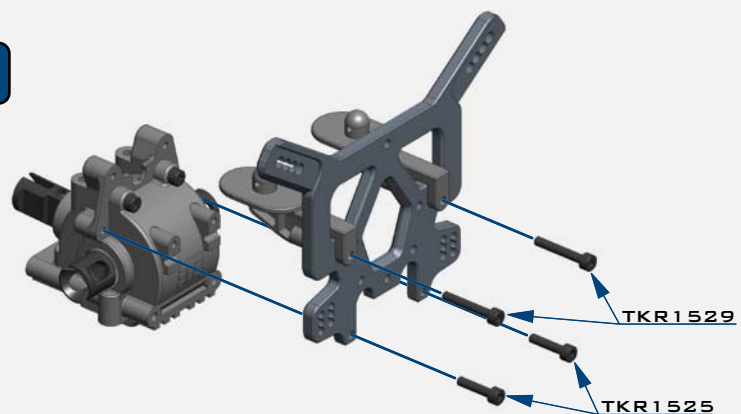

BAG G

LOW PROFILE WING MOUNT

SETTINGS

POSITION SETTINGS

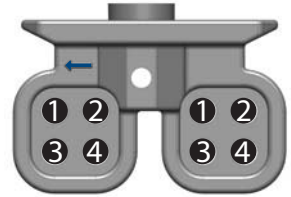

- 1 - REARWARD LOW
- 2 - FORWARD LOW
- 3 - REARWARD HIGH
- 4 - FORWARD HIGH

Note: Stock position setting is # 3, Rearward High

DOWNFORCE SETTINGS

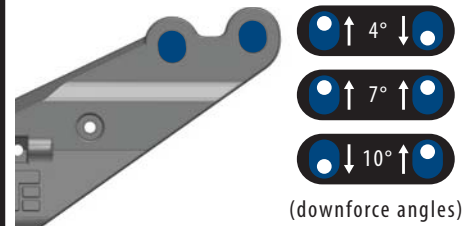

(downforce angles)

Note: Stock downforce setting is 4°

STEP G-1

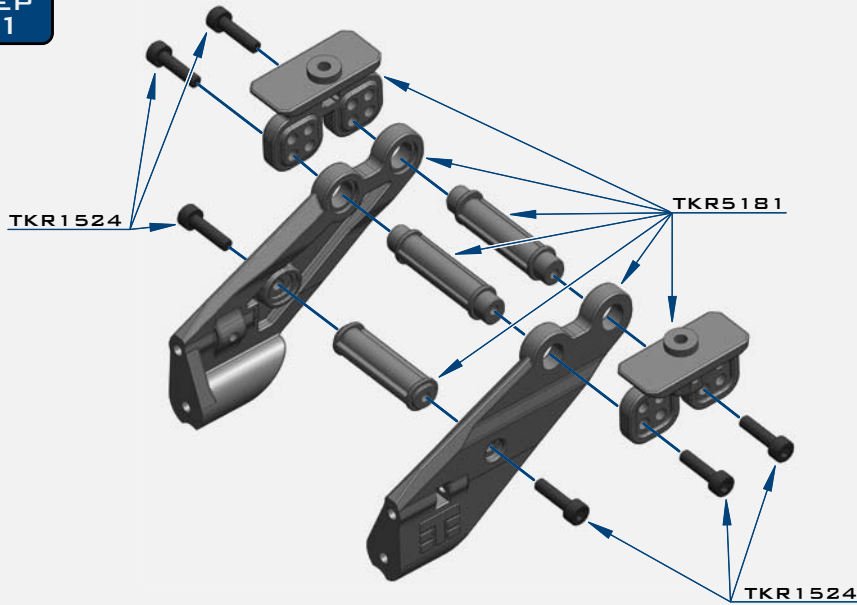

STEP G-2

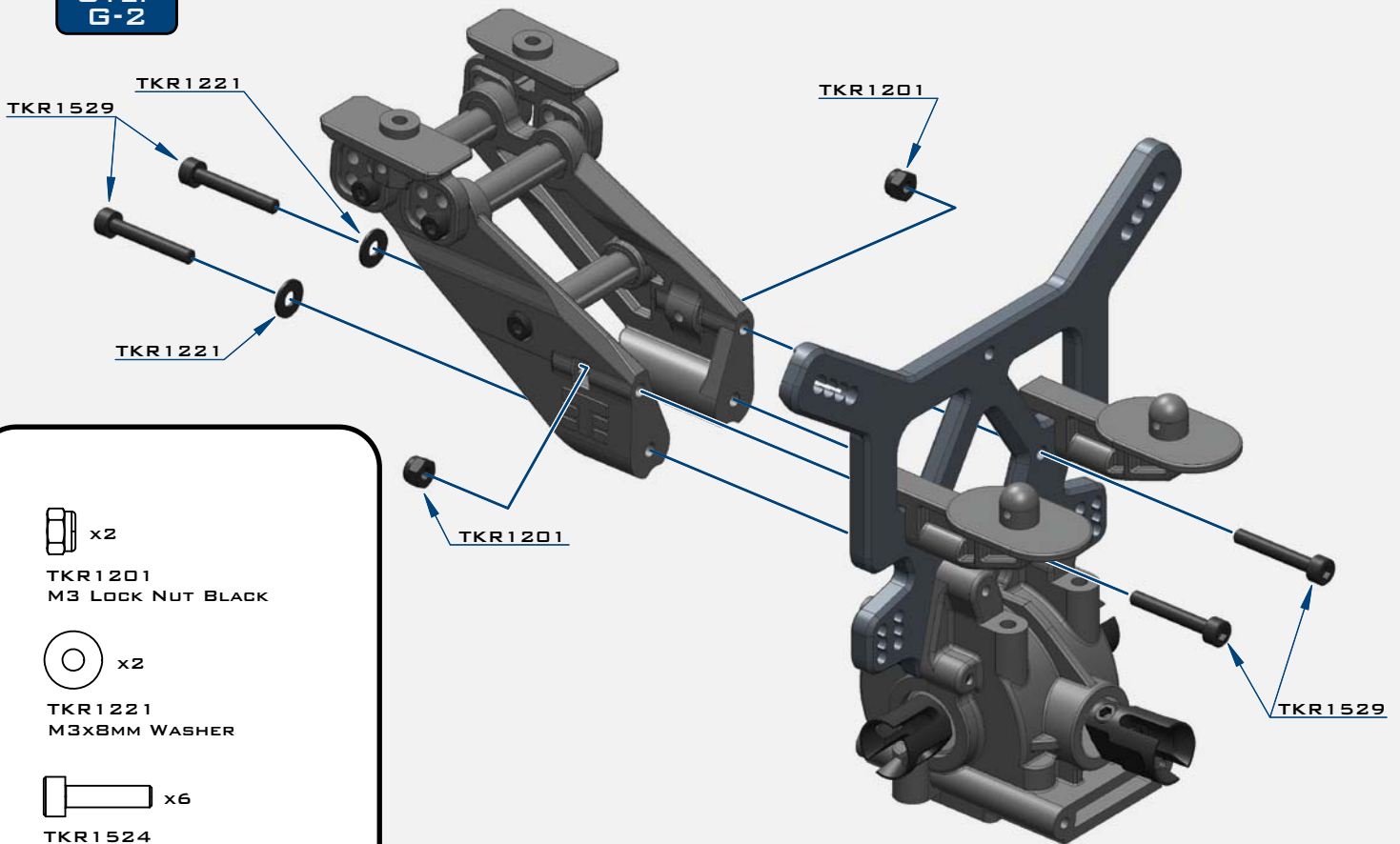

x2

TKR1201
M3 LOCK NUT BLACK



x2

TKR1221
M3X8MM WASHER

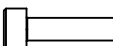

x6

TKR1524
M3X12MM CAP HEAD SCREW

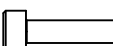

x4

TKR1529
M3X20MM CAP HEAD SCREW

BAG H

REAR END

STEP H-1

- TKR5493 - 2.6MM
- *TKR5490 - 2.3MM
- *TKR5491 - 2.4MM
- *TKR5492 - 2.5MM
- *TKR5494 - 2.8MM
- *TKR5495 - 3.0MM
- (OPTION)

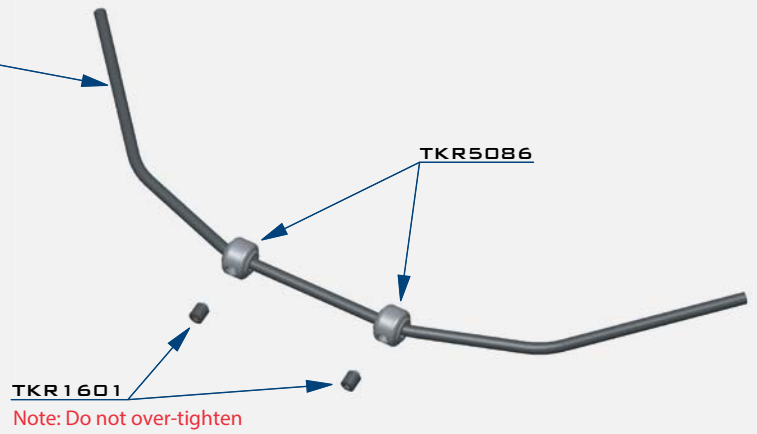
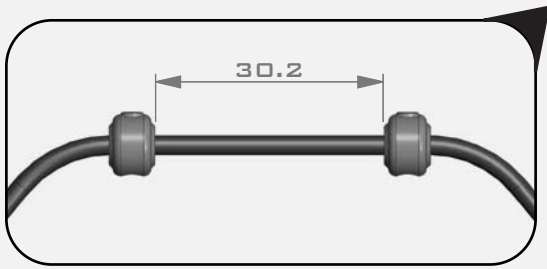

STEP H-2

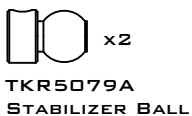
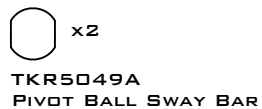
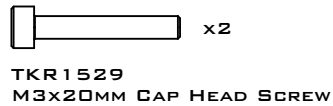
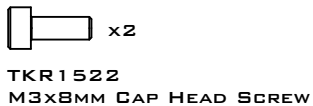
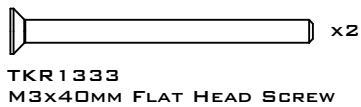
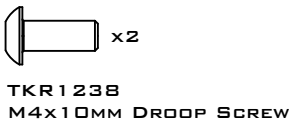
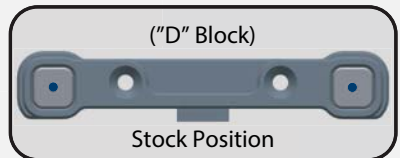
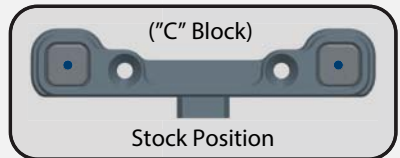
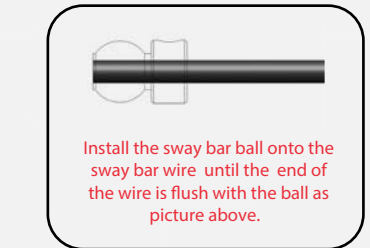
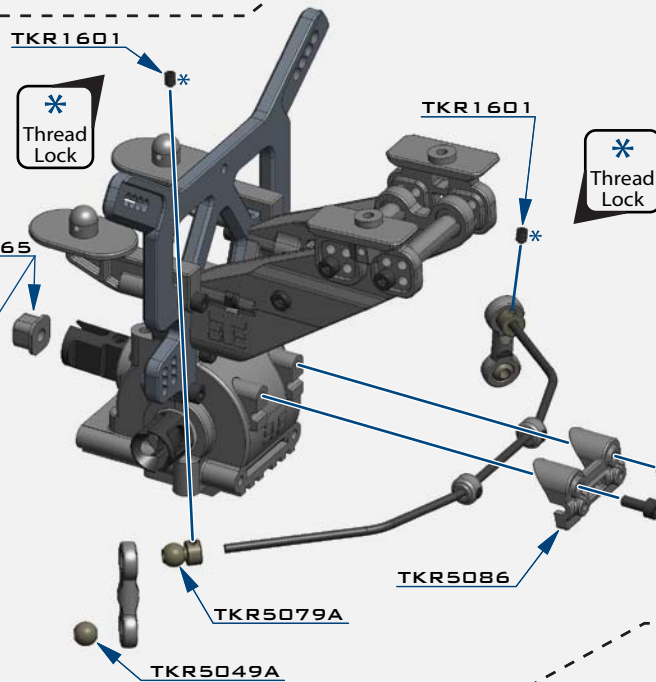
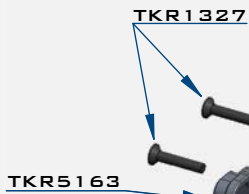

STEP H-3

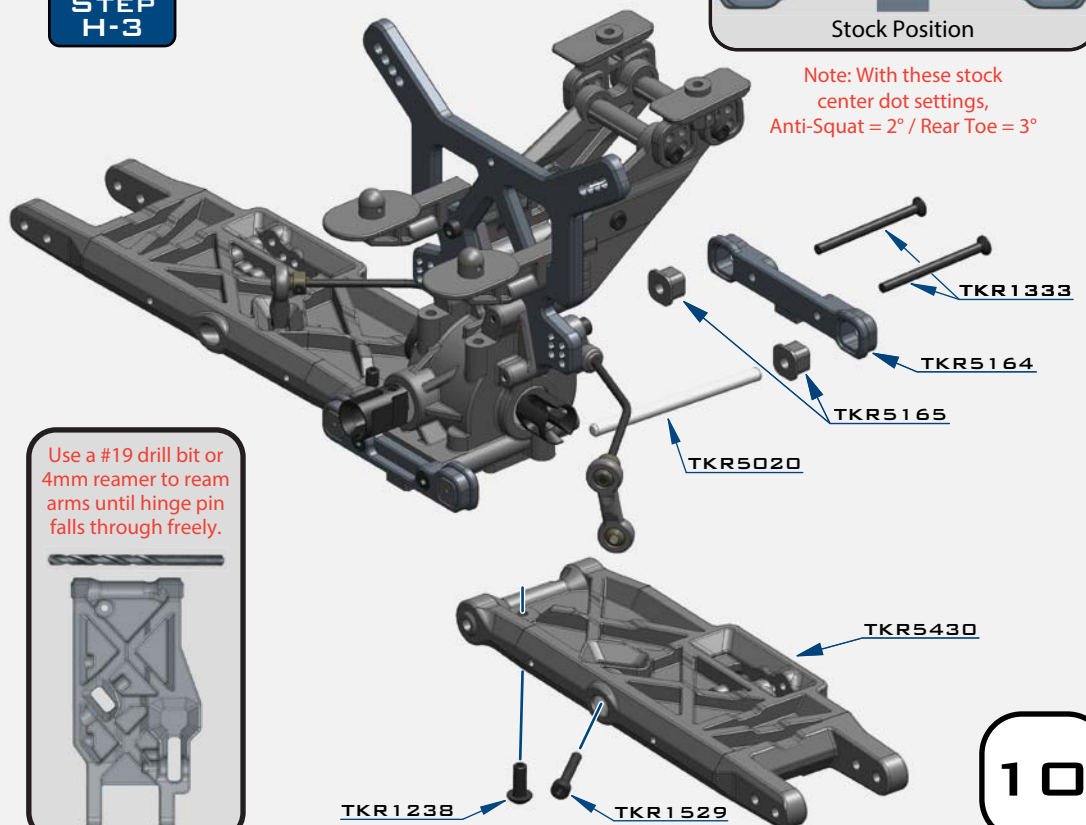

BAG I

REAR HUB/CVA ASSEMBLY

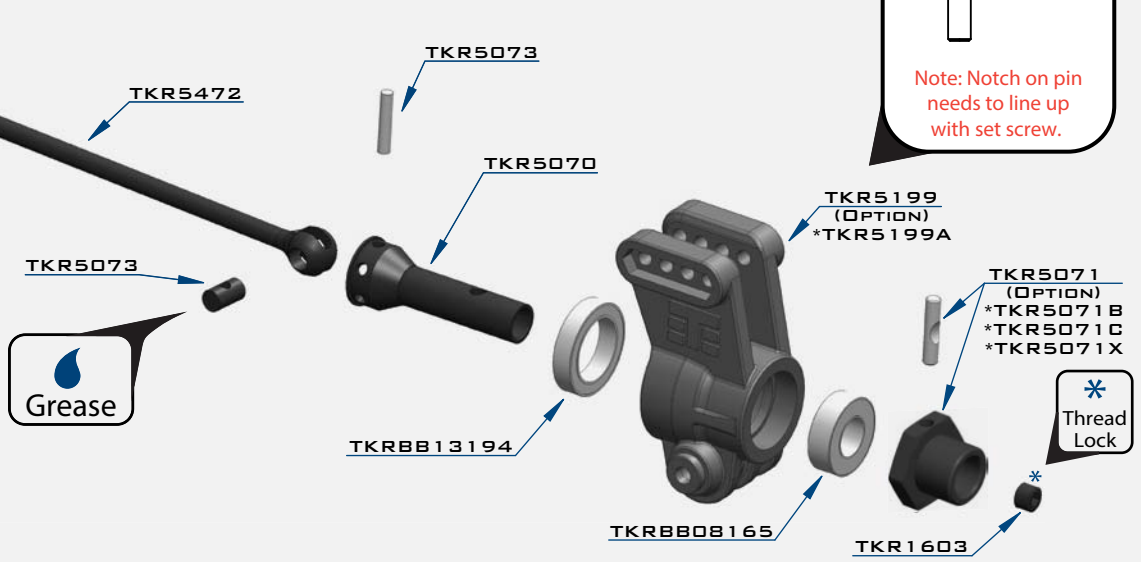

Note: Notch on pin needs to line up with set screw.

STEP 1-1

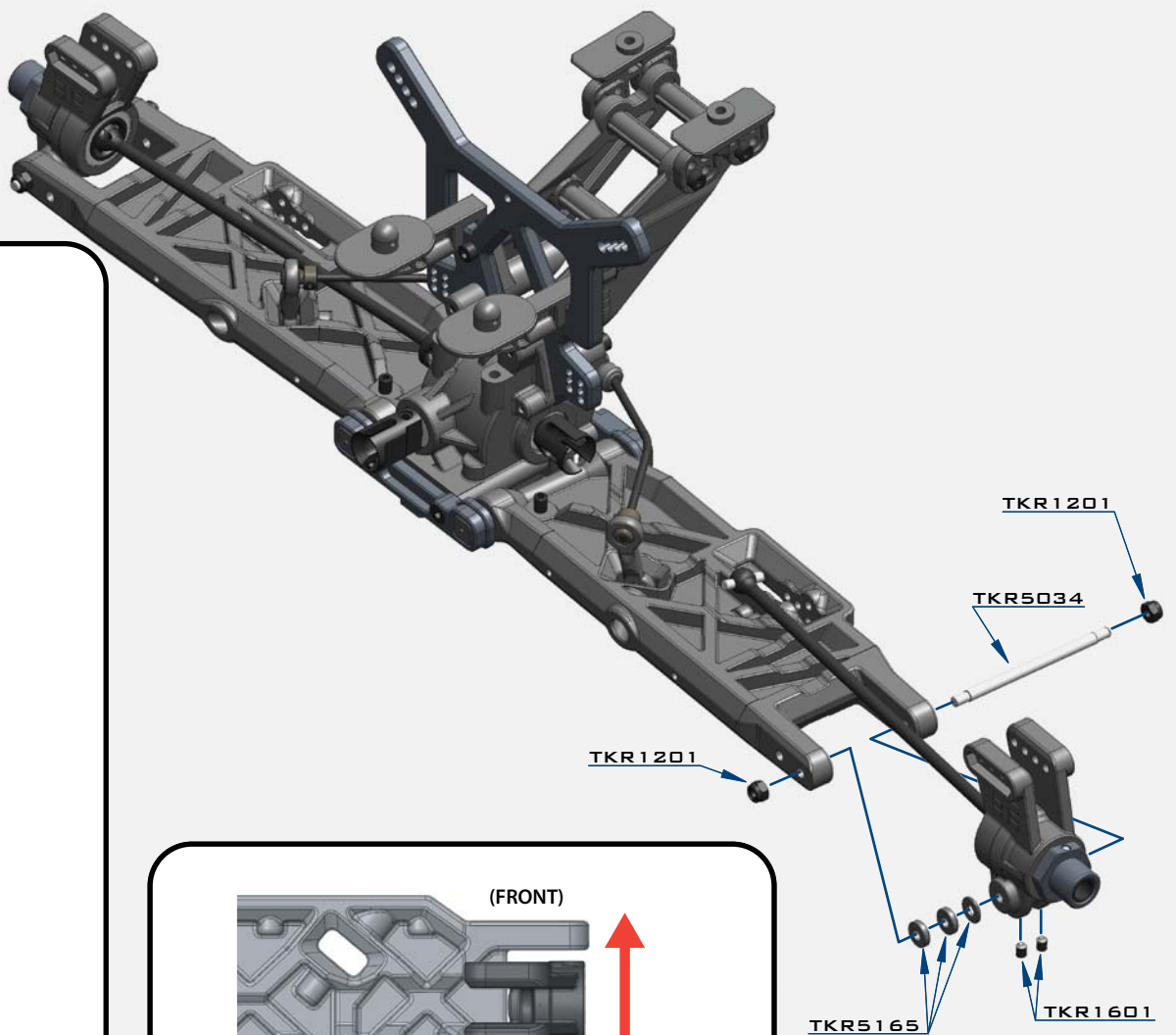

STEP 1-2

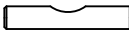
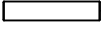
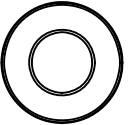
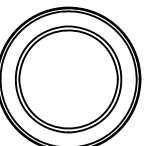

-  x4
TKR1201
M3 LOCKNUT BLACK
-  x4
TKR1601
M3X4MM SET SCREW
-  x2
TKR1603
M5X4MM SET SCREW
-  x2
TKR5071
M3X16.8MM PIN
-  x2
TKR5073
CV JOINT PIN
-  x2
TKRBB08165
BALL BEARING (8X16X5)
-  x2
TKRBB13194
BALL BEARING (13X19X4)

(FRONT)  (REAR)

Changes to the wheelbase have a dramatic effect on handling, since it shifts the distribution of weight over the rear wheels. This adjusts traction. By shortening the wheelbase at the rear, you are placing more weight over the rear wheels.

Changes to the wheelbase also change the amount of sweep the rear driveshaft will have. More driveshaft sweep creates an effect similar to anti-squat, where the rear end gets pushed upwards on throttle. This helps reduce chassis slap when landing jumps on throttle.

BAG I

REAR CAMBER LINKS

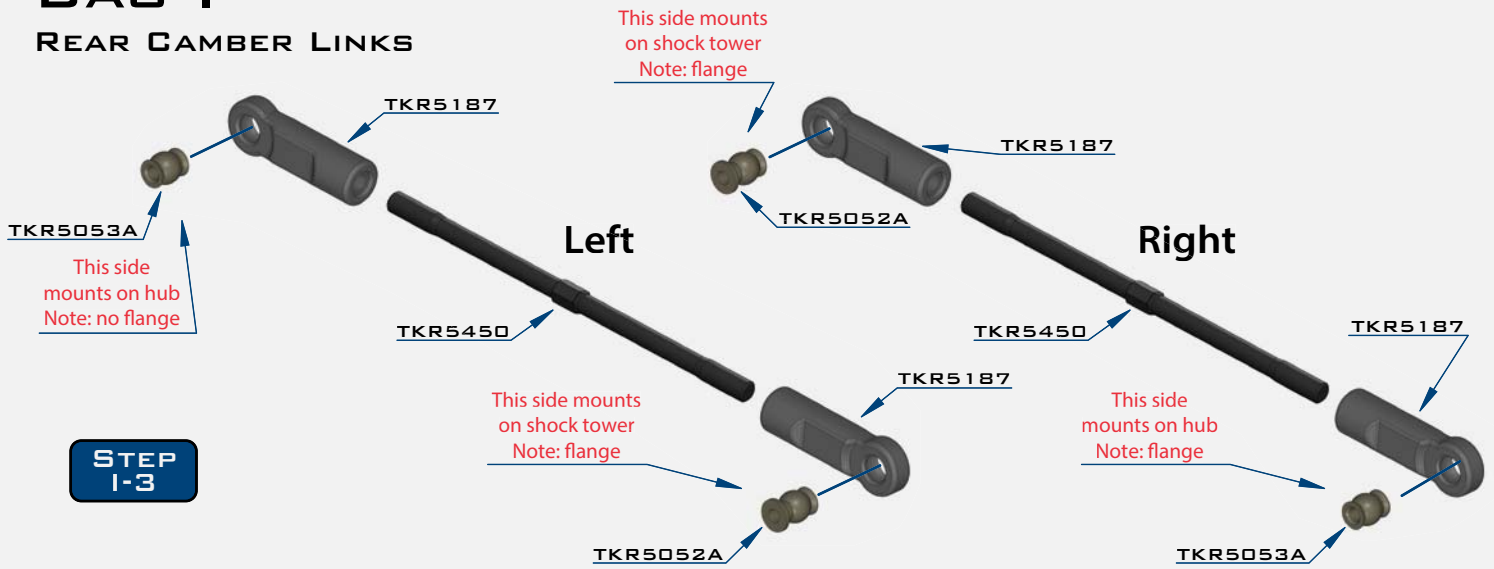

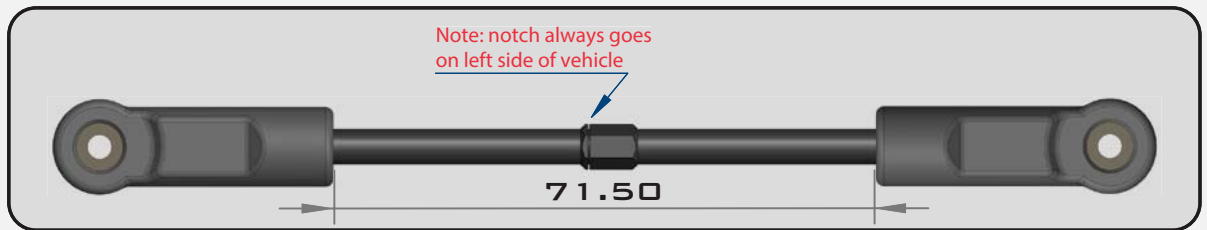

STEP 1-3

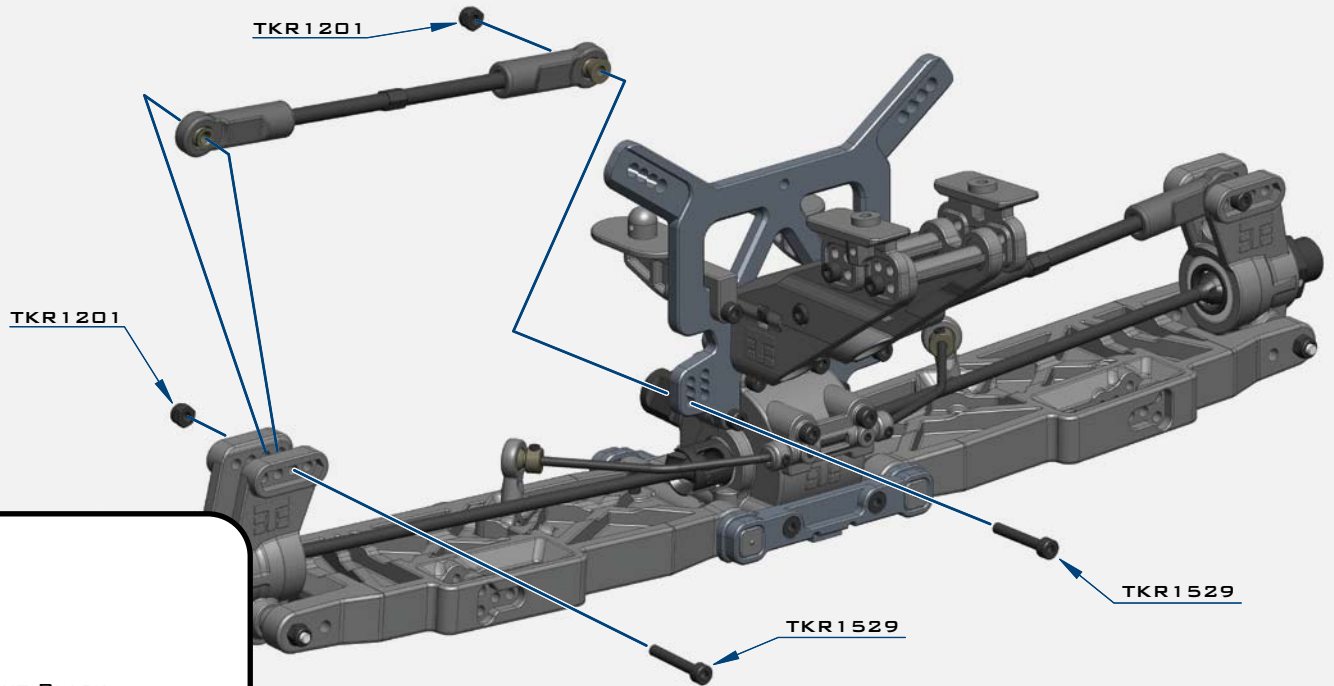

STEP 1-4

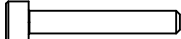

-  x4
TKR1201
M3 LOCKNUT BLACK
-  x4
TKR1529
M3X20MM CAP HEAD SCREW
-  x2
TKR5052A
PIVOT BALL M3X6.8MM
-  x2
TKR5053A
PIVOT BALL M3X6.8MM
NO FLANGE

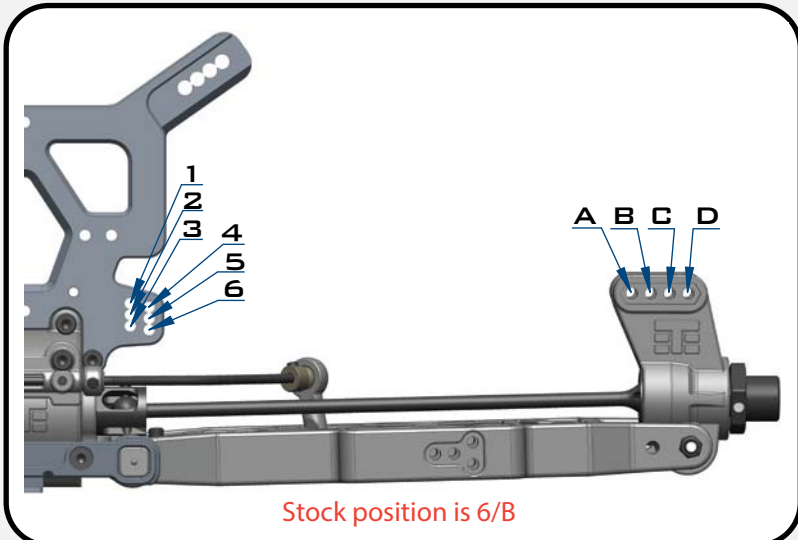

BAG J

FRONT END

STEP J-1

- TKR5482 - 2.5MM
- *TKR5480 - 2.3MM
- *TKR5481 - 2.4MM
- *TKR5483 - 2.6MM
- *TKR5484 - 2.8MM
- *TKR5485 - 3.0MM
- (OPTION)

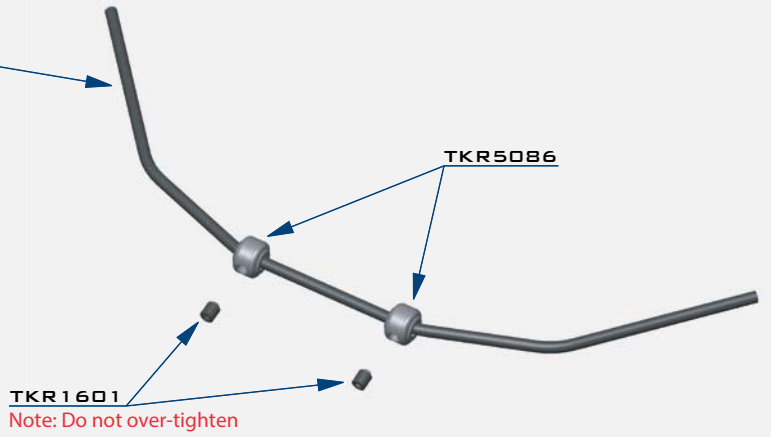
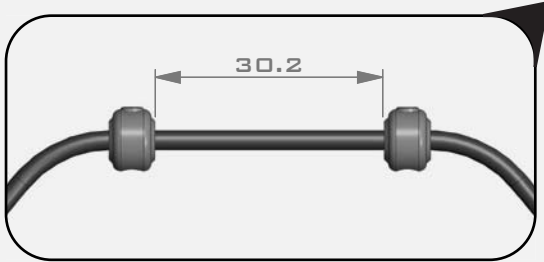

TKR1601
Note: Do not over-tighten

STEP J-2

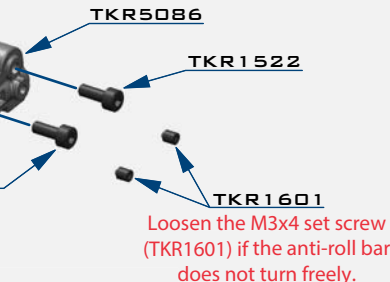
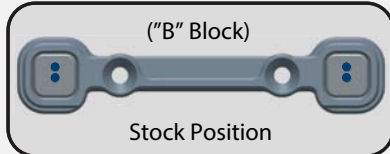
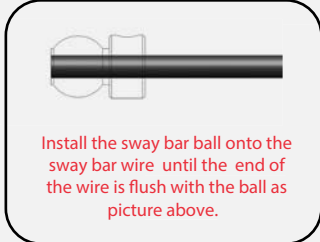
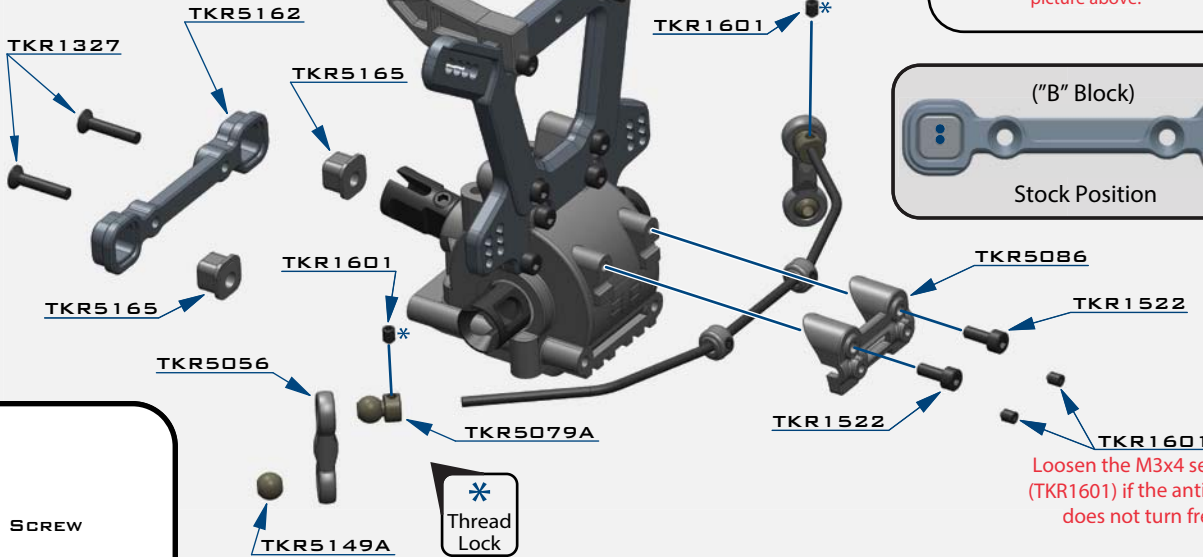

- x2
TKR1238
M4X10MM DROOP SCREW
- x2
TKR1327
M3X16MM FLAT HEAD SCREW
- x2
TKR1333
M3X40MM FLAT HEAD SCREW
- x2
TKR1522
M3X8MM CAP HEAD SCREW
- x2
TKR1529
M3X20MM CAP HEAD SCREW
- x6
TKR1601
M3X4MM SET SCREW
- x2
TKR5049A
PIVOT BALL SWAY BAR
- x2
TKR5079A
STABILIZER BALL

STEP J-3

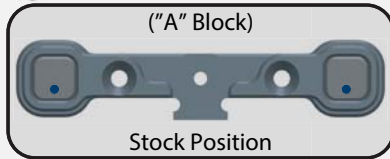
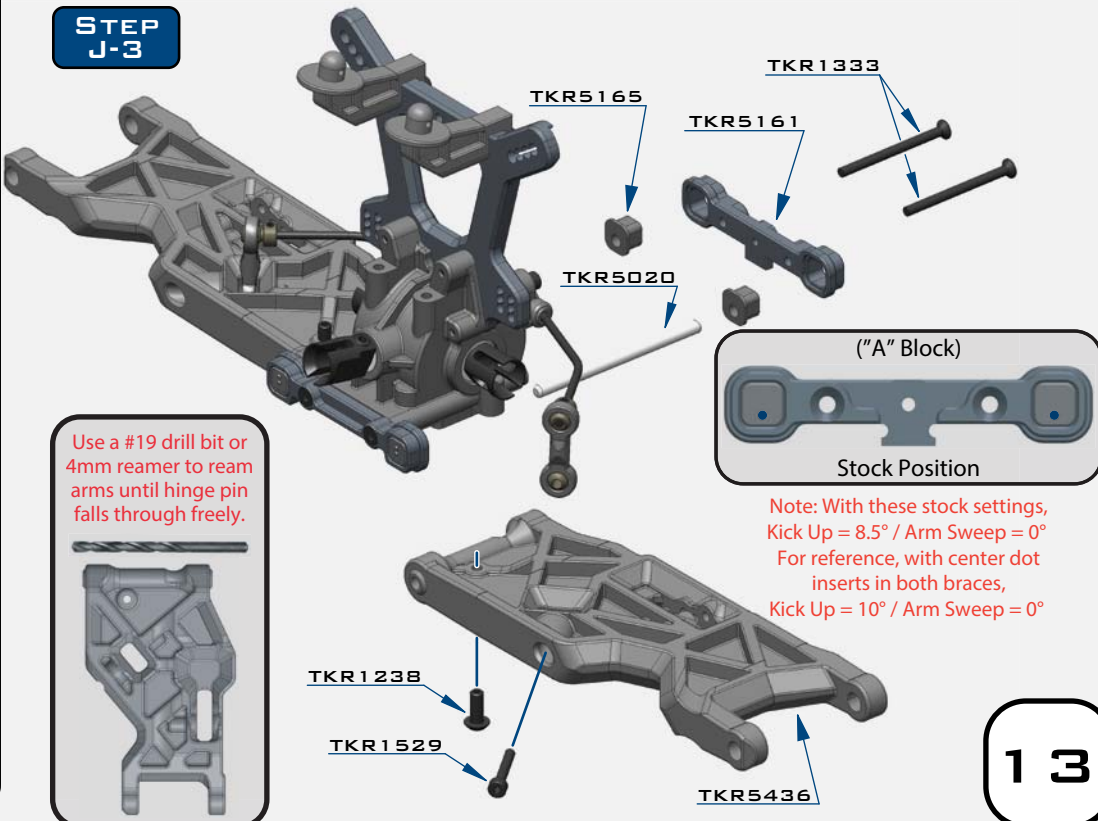

Note: With these stock settings,
Kick Up = 8.5° / Arm Sweep = 0°
For reference, with center dot
inserts in both braces,
Kick Up = 10° / Arm Sweep = 0°

BAG K

FRONT SPINDLE / CVA ASSEMBLY

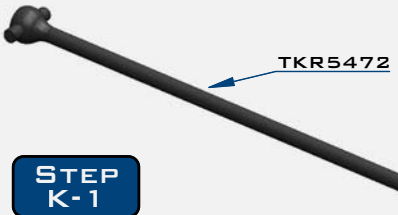
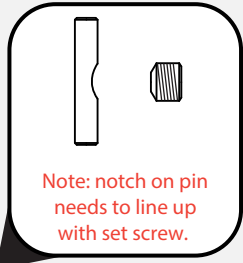

STEP K-1

-  x8
TKR1221
M3x8MM WASHER
-  x2
TKR1401
M3x6MM BUTTON HEAD SCREW
-  x4
TKR1445
M4x14MM BUTTON HEAD SCREW
-  x4
TKR1447
M4x16MM BUTTON HEAD SCREW
-  x8
TKR1601
M3x4MM SET SCREW
-  x2
TKR1603
M5x4MM SET SCREW
-  x4
TKR5054A
SPINDLE PIN SLEEVE
-  x4
TKR5055A
SUSPENSION PIN SLEEVE
-  x2
TKR5071
M3x16.8MM PIN
-  x2
TKR5073
CV JOINT PIN
-  x2
TKRBB08165
BALL BEARING (8x16x5)
-  x2
TKRBB13194
BALL BEARING (13x19x4)

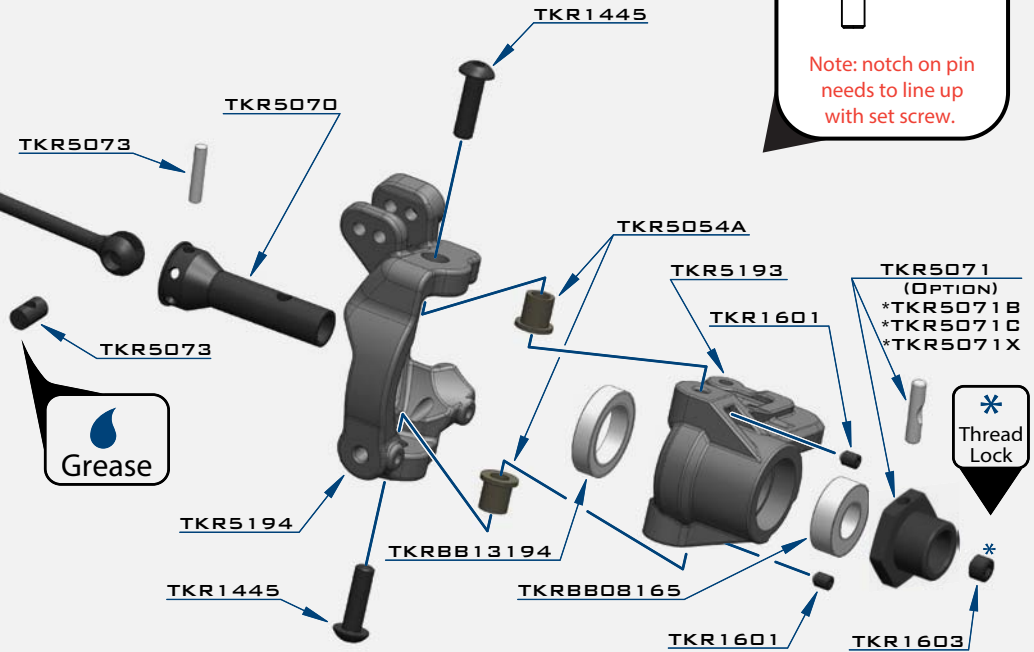

Note: The TKR1601 set screws are meant to keep the TKR1445 screws from coming loose. After installing TKR1445 and ensuring the steering action is free, install TKR1601 in the locations indicated. Very slowly tighten the screws until you feel some resistance from contacting the TKR1445 screws. DO NOT OVERTIGHTEN. Also be sure to loosen TKR1601 before unscrewing TKR1445 or you will damage the screws and the parts.

STEP K-2

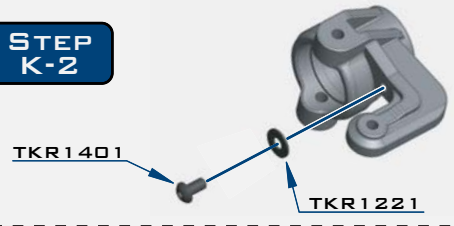

Note: The steering stops provide adjustable travel limiters that you can adjust to your driving style. For very tight tracks you may want to experiment with less limiting washers (more steering travel). However, with too much steering travel the rear end can lose traction more easily coming out of corners. After months of testing on different track surfaces, 1 washer is the best starting point.

STEP K-3

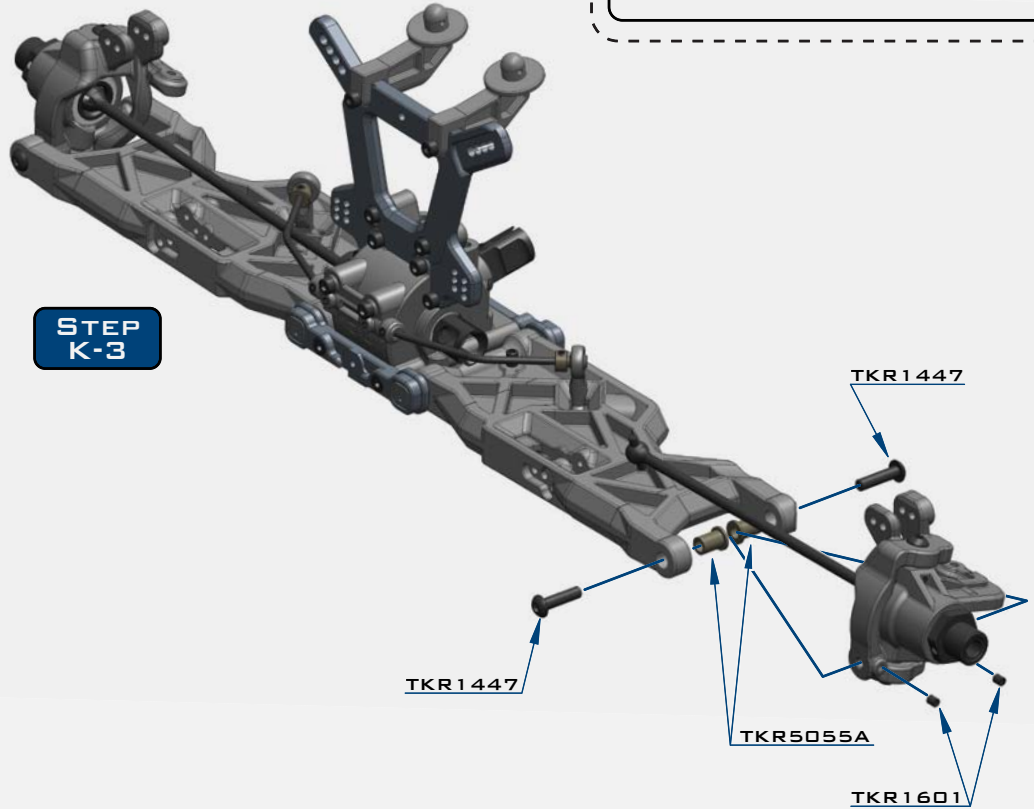

Note: The TKR1601 set screws are meant to keep the TKR1447 screws from coming loose. After installing TKR1447 and ensuring the steering action is free, install TKR1601 in the locations indicated. Very slowly tighten the screws until you feel some resistance from contacting the TKR1447 screws. DO NOT OVERTIGHTEN. Also be sure to loosen TKR1601 before unscrewing TKR1447 or you will damage the screws and the parts.

BAG K

FRONT CAMBER LINKS

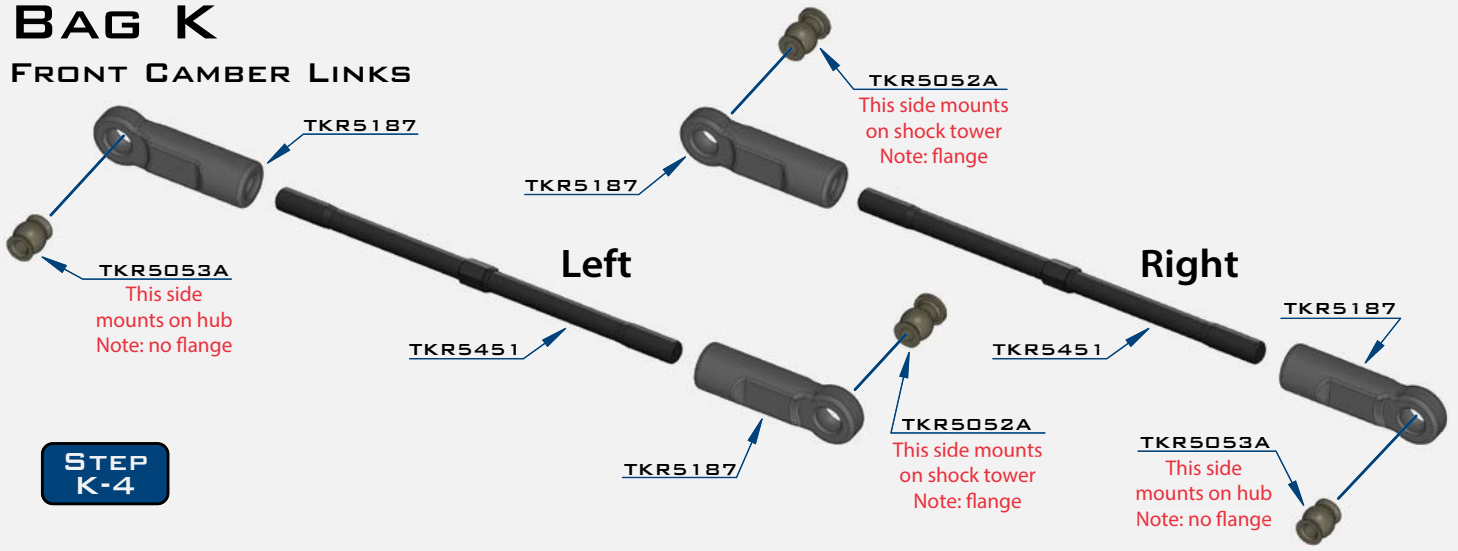

STEP K-4

STEP K-5

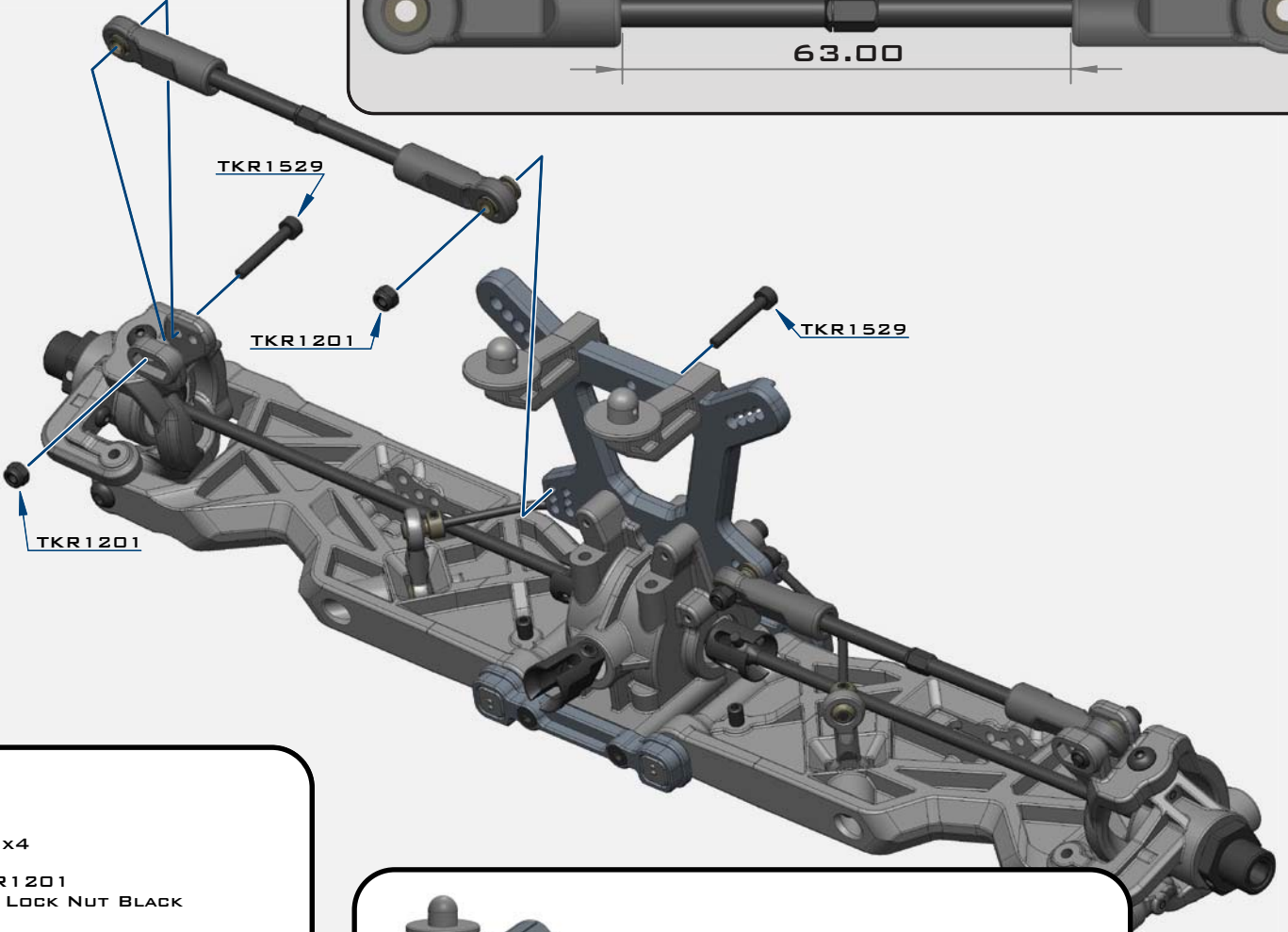
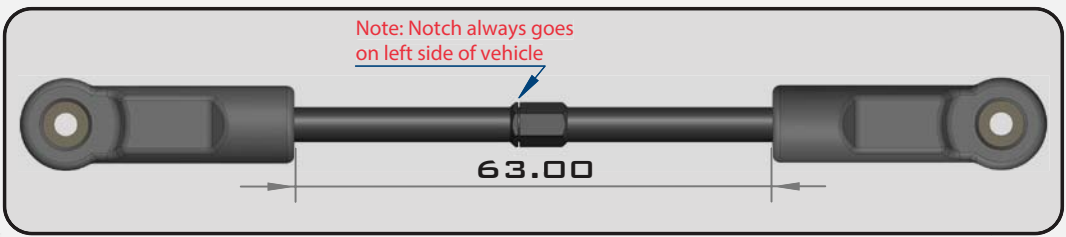

x4
TKR1201
M3 LOCK NUT BLACK

x4
TKR1529
M3X20MM CAP HEAD SCREW

x2
TKR5052A
PIVOT BALL M3X6.8MM

x2
TKR5053A
PIVOT BALL M3X6.8MM
NO FLANGE

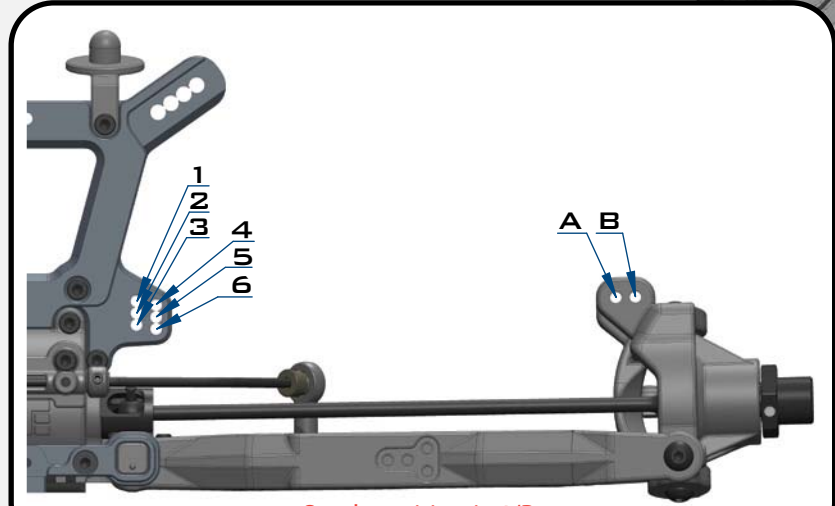

Stock position is 4/B

BAG L

STEERING ASSEMBLY (OVERVIEW)

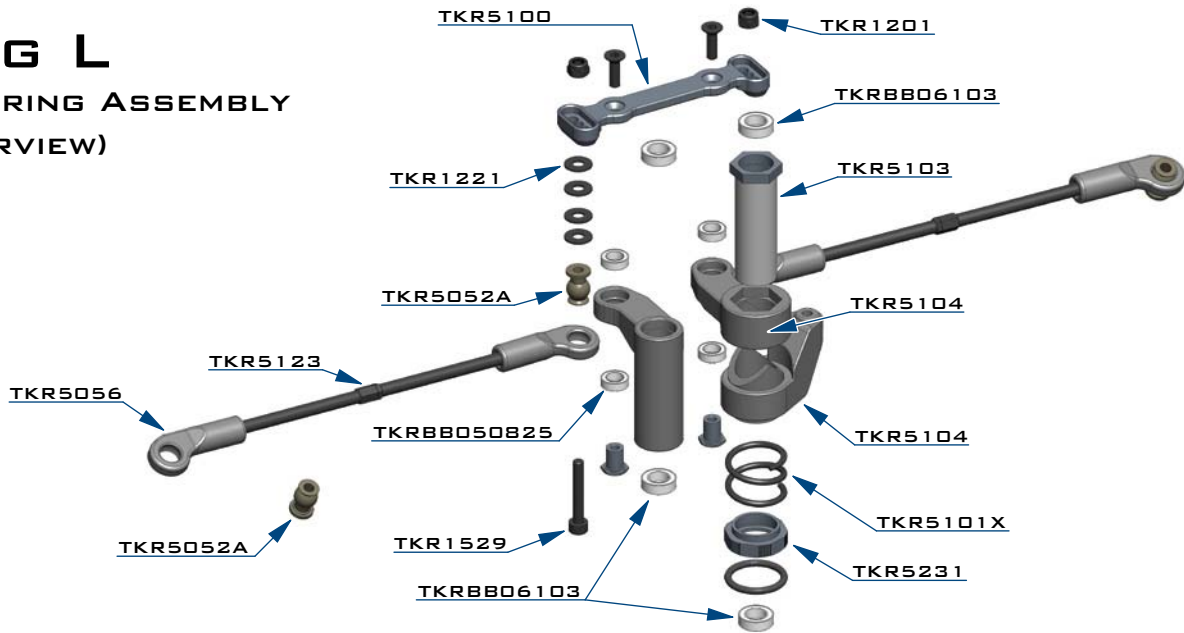

STEP L-1



Note: Tighten nut all the way down, then back it off 3 full turns

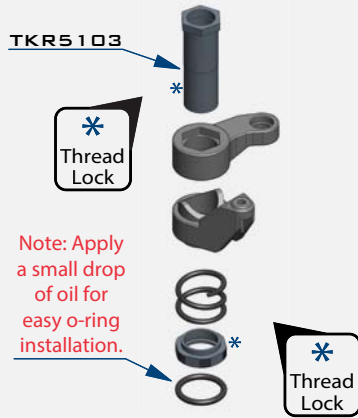



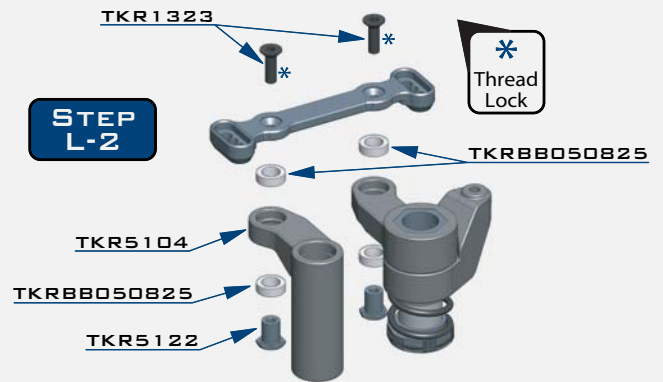

Note: Apply a small drop of oil for easy o-ring installation.

Thread Lock

STEP L-2



Thread Lock

-  x2
TKR1201
M3 LOCK NUT BLACK
-  x8
TKR1221
M3x8MM WASHER
-  x2
TKR1323
M3x10MM FLAT HEAD SCREW
-  x2
TKR1529
M3x20MM CAP HEAD SCREW
-  x4
TKR5052A
PIVOT BALL M3x6.8MM

STEP L-3

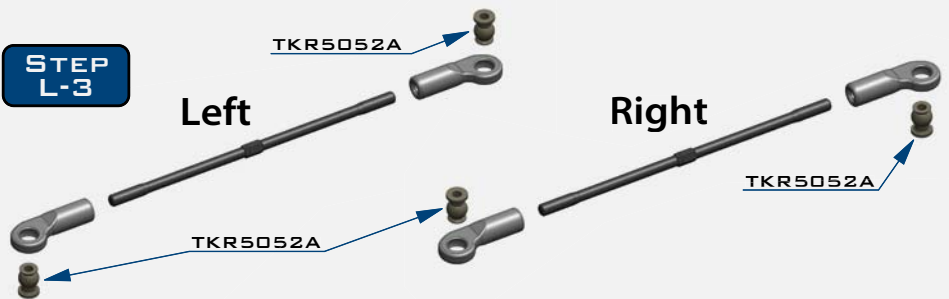

Left

Right

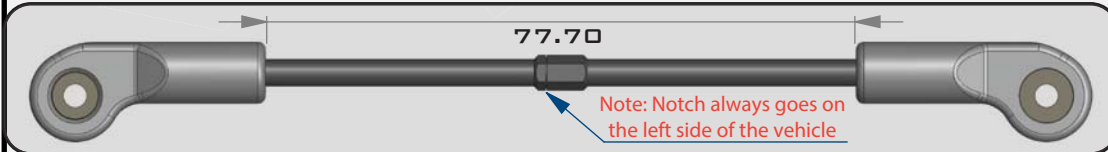

Note: Notch always goes on the left side of the vehicle

STEP L-4

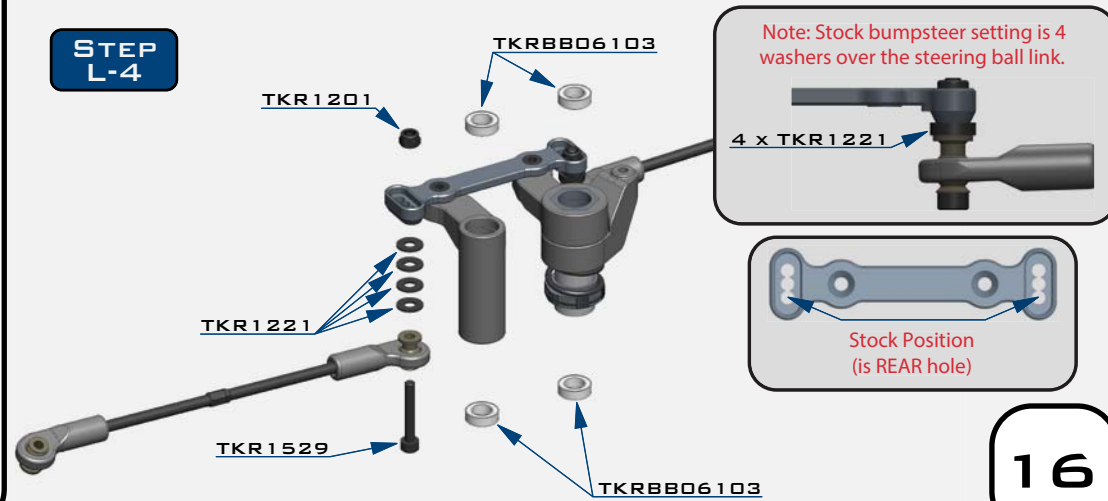

Note: Stock bumpsteer setting is 4 washers over the steering ball link.



BAG M

FRONT END ASSEMBLY

STEP M-1

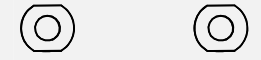
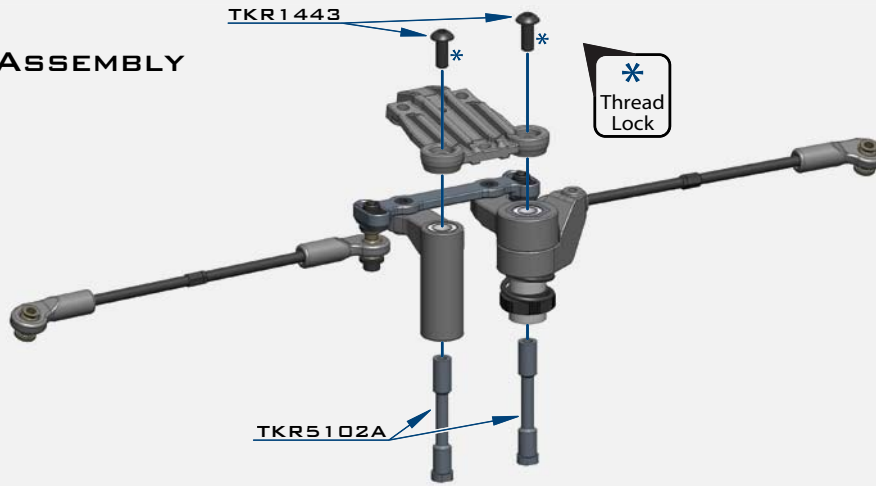

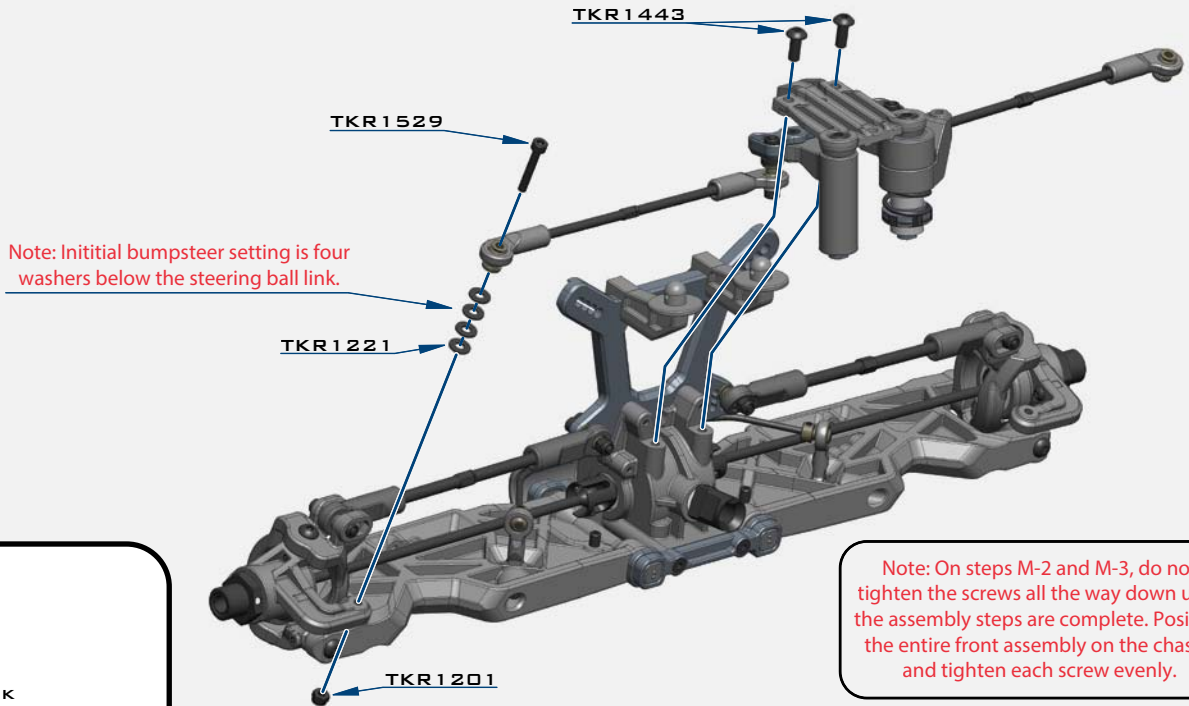

Note Step K-2:
Line up the bottom of the steering posts (TKR5102A) with the corresponding recessed cut in the chassis.

STEP M-2





Note: On steps M-2 and M-3, do not tighten the screws all the way down until the assembly steps are complete. Position the entire front assembly on the chassis and tighten each screw evenly.

 x2
TKR1201
M3 LOCK NUT BLACK

 x8
TKR1221
M3X8MM WASHER

 x2
TKR1343
M4X10MM FLAT HEAD SCREW

 x6
TKR1344
M4X12MM FLAT HEAD SCREW

 x5
TKR1443
M4X10MM BUTTON HEAD SCREW

 x1
TKR1522
M3X8MM CAP HEAD SCREW

 x2
TKR1529
M3X20MM CAP HEAD SCREW

STEP M-3

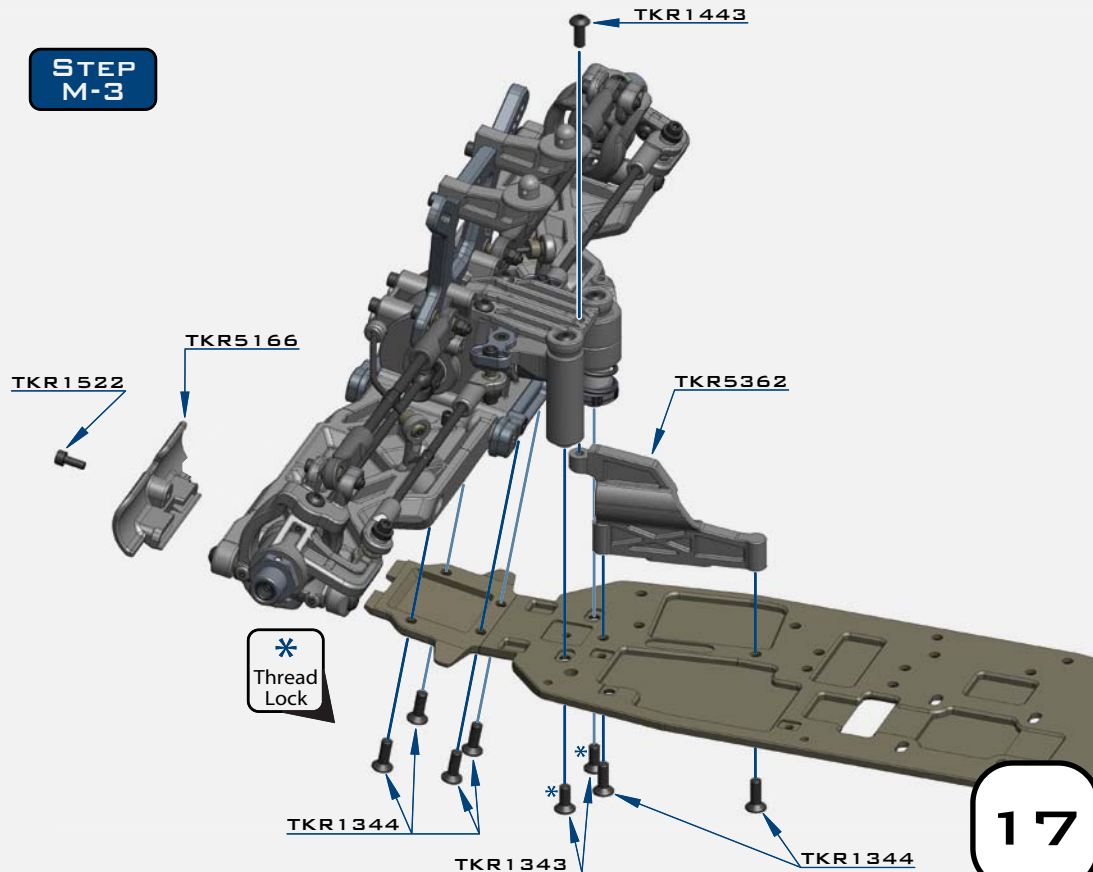

BAG N

CENTER/REAR ASSEMBLY

STEP
N-1

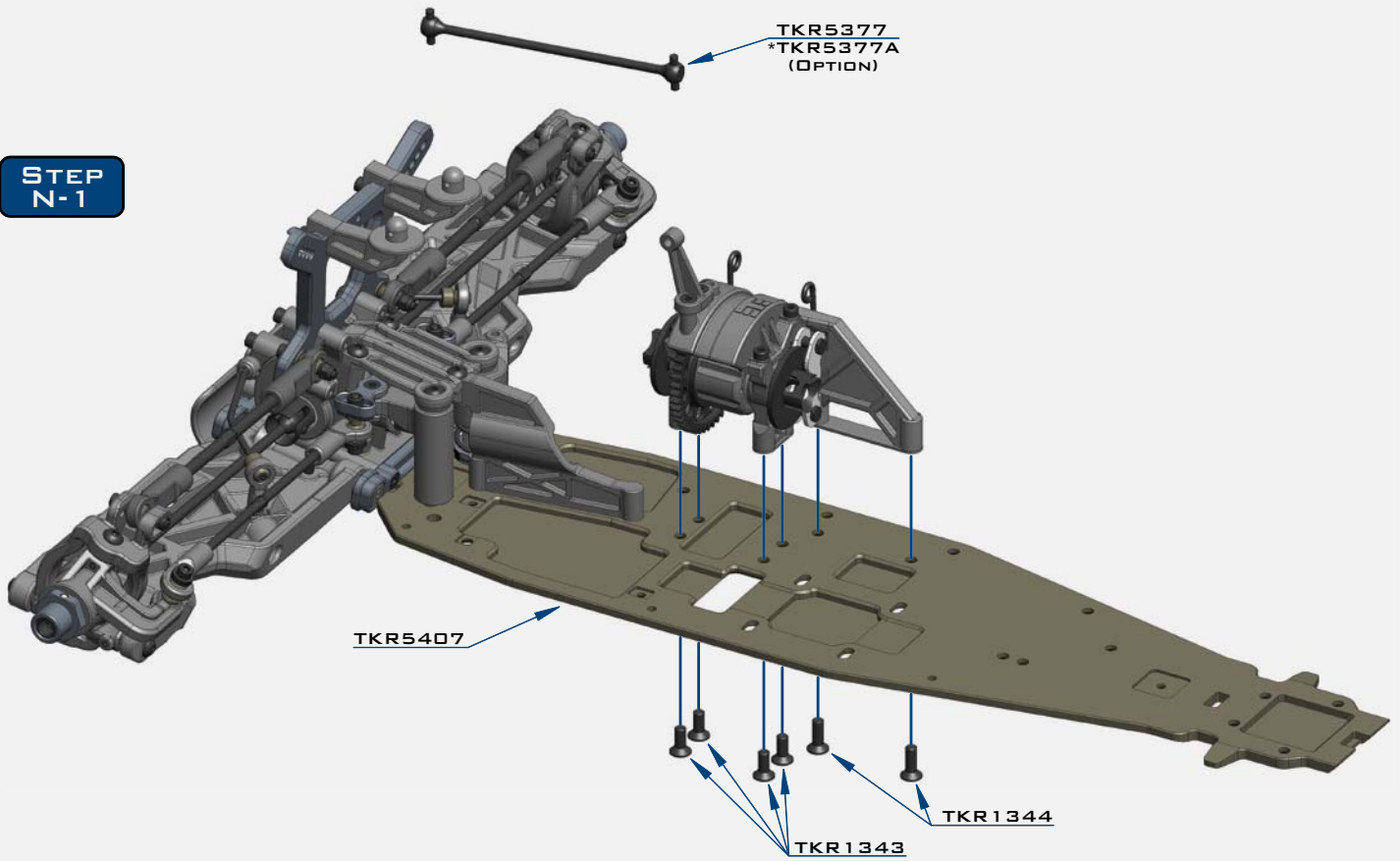

STEP
N-2

Note: Two rear chassis braces are included in the kit. The longer brace is the stock brace. The short brace is optional. The longer brace will provide less flex. Adding the short brace will further stiffen the chassis. Running only the short brace will provide the most flex.

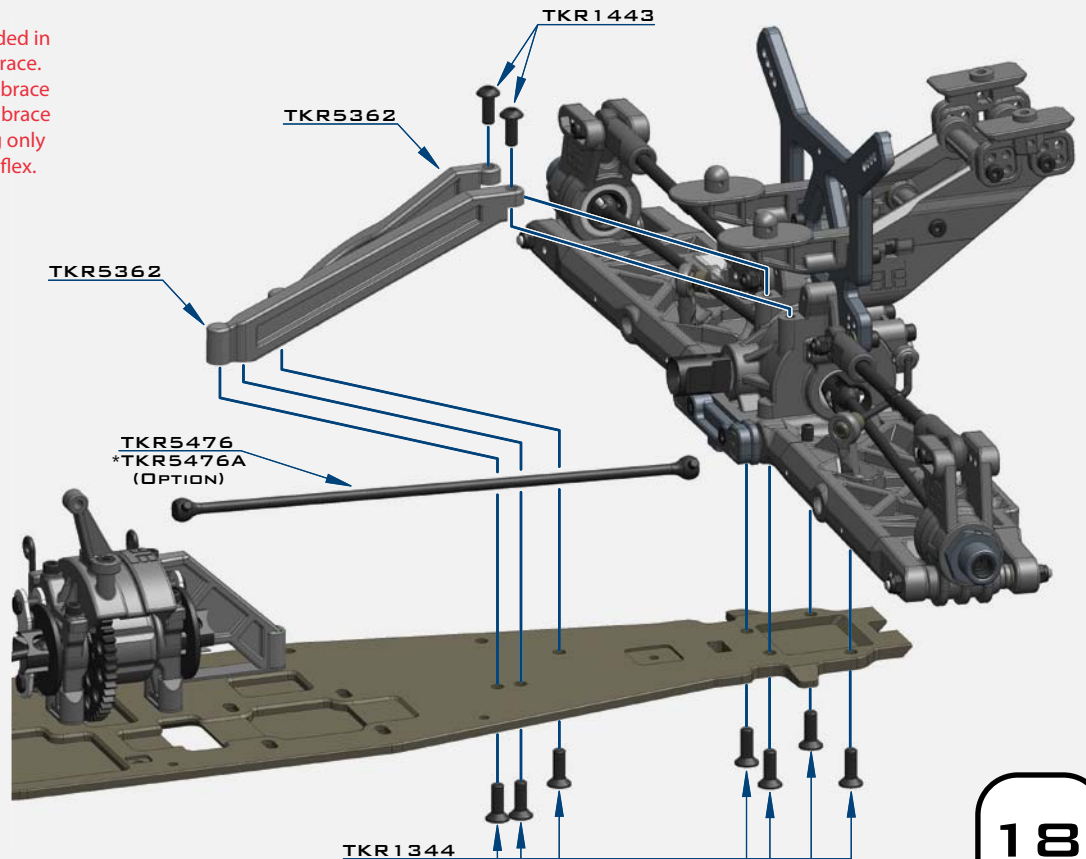

x4

TKR1343
M4x10MM FLAT HEAD SCREW

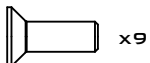

x9

TKR1344
M4x12MM FLAT HEAD SCREW



x2

TKR1443
M4x10MM BUTTON HEAD SCREW

SHOCK FILLING INSTRUCTIONS

FOR BOTH FRONT AND REAR SHOCKS

The following steps and information will provide you with the best way to fill and bleed your shocks. After thorough testing, we've found it's easiest to complete steps 1 through 3 on each shock before moving onto step 4. By the time you've finished step 3 on the last shock the first one will be ready for step 4.

Standard or Vented Cap Build:

Step 1: Extend the shock shaft all the way down. Fill the shock with oil until it is about 90% full.

Step 2: Slowly pump the shock shaft up and down 3-5 times to release air bubbles from underneath the piston.

Step 3: Let the shock rest vertically with the shock shaft fully extended for five minutes or until all the air bubbles have released.

Step 4: Next you will top off the shock with oil, to about 1-2mm below the top edge.

(If you do overfill the shock, it won't hurt performance, it will just spill out and make a little bit of a mess. If you underfill the shock, it will cause air to be trapped inside.)

Step 5: Place the bladder *INSIDE* the shock cap and put a few drops of oil on the bladder.

Step 6: Put a paper towel down below the build to catch drips and have another ready to wipe off excess oil. Place the cap on the shock and screw down about half way. Lay the shock over about 45 degrees with the bleeder hole facing up.

Step 6A: (Standard non-vented "Stock") Push the shaft in for the amount of rebound desired.

Step 6B: (Vented) Push the shaft in until about 15mm of shaft is showing.

- Make sure that you match the rebound amount between the left and right shocks.
- Oil should be oozing out of the bleeder hole.

Step 7: Hold the cap firmly in place with the bleeder hole facing up and turn the shock body until hand tight. The shock will continue to ooze oil.

Step 8: Fully tighten down each shock with shock tools until cap is secure and wipe excess oil away.

Emulsion Build:

Prep your shock caps TKR6018 (optional for NT48) accordingly by drilling out the large angled bleeder hole in the top of the cap. Place the larger thin o-ring around the base of the threads where the shock cap screws on (see diagram on the next page). This seal is crucial to the build.

Follow steps 1-4 above.

Step 5: Rebound is more of a natural side effect of an emulsion shock. It's not something that can be set accurately because you run the risk of hydrolocking the shock if you do not push the shaft all the way in when you bleed it. For now leave the shaft fully extended.

Step 6: Fill the shock up, over filling just slightly without spilling to create a small dome of oil.

Step 7: Place a little bit of oil in the shock cap and quickly put the shock cap on the shock body. Tighten the cap all the way down. Very slowly push the shaft in. Oil will start to bleed out of the top of the cap. While wiping away excess oil, continue to slowly push the shaft in *ALL THE WAY*.

If no oil comes out when the shaft is fully inserted, you will need to start over at step 6.

Step 8: Install the TKR1341 M4x6mm flat head screw and TKR5125 black o-ring to seal the cap (see diagram). Tighten until o-ring is fully seated.

BAG O

FRONT SHOCK ASSEMBLY

STEP 0-1

Note: Make sure to tighten both cartridge cap (TKR6015) and shock cap (TKR6003B) to ensure a proper seal. Tools may be required.

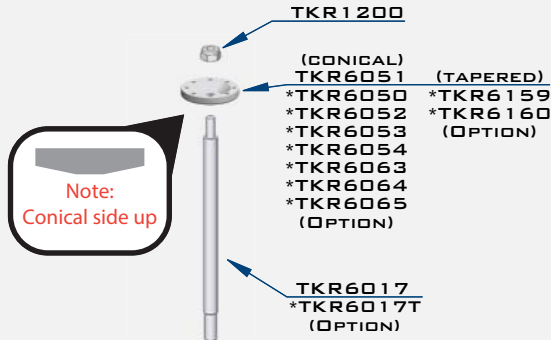
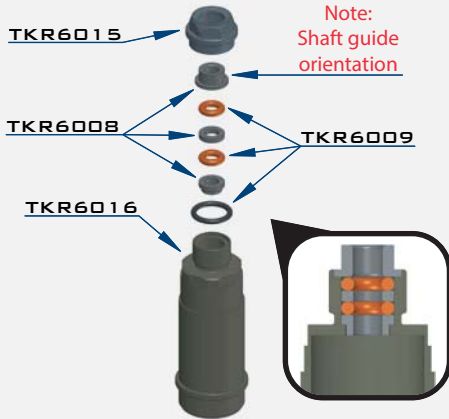

Note: Use green slime or oil on shock shaft threads AND O-rings to prevent tearing and leaking.

Fill oil level just below the top of the shock body. Use #650wt oil FRONT

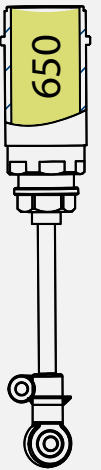

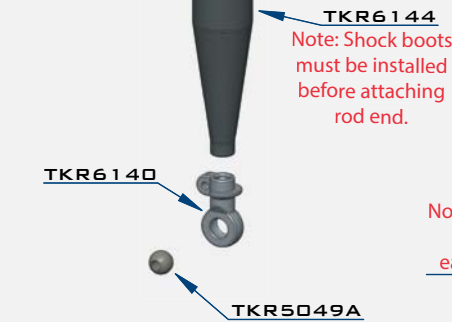

Note: Apply a small drop of oil for easy installation.

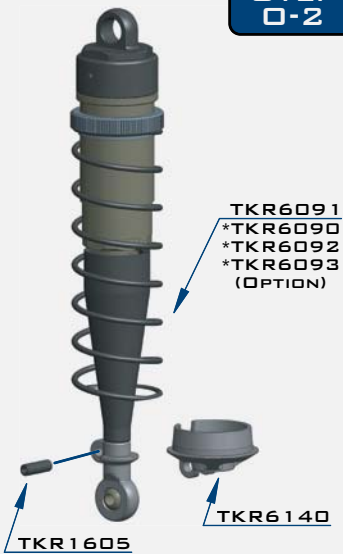

Note: Front shocks use shorter shock bodies - TKR6016, shorter shock shafts - TKR6017, shorter springs - TKR6091 and shorter shock boots - TKR6144

STEP 0-2



 x2
TKR1200
M2.5 LOCK NUT ZINC

 x2
TKR1202
M4 LOCK NUT BLACK

 x2
TKR1211
M3 LOCK NUT FLANGE BLACK

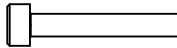
 x2
TKR1529
M3X20MM CAP HEAD SCREW

 x2
TKR1605
M3X10MM SET SCREW

STEP 0-3

TKR1211

Note: Tighten TKR1211 lock nut all the way down, then back off 1/4 turn. Use thread lock!

 Thread Lock

Note: Slot in spring perch should face outside of vehicle.

TKR1529

- Stock shock position is outside hole on the arm and 2nd from outside hole on the tower
- Stock front ride height 37mm
- Shock length (droop) 122mm

BAG P

REAR SHOCK ASSEMBLY

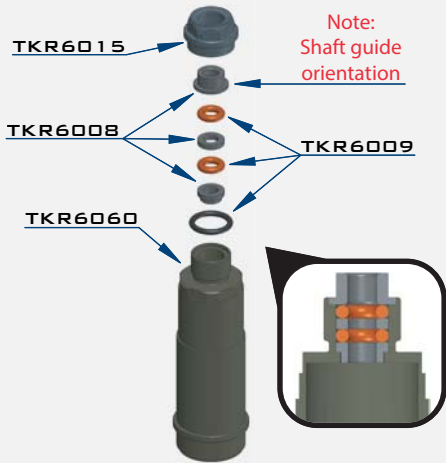

STEP P-1

Note: Make sure to tighten both cartridge cap (TKR6015) and shock cap (TKR6003B) to ensure a proper seal. Tools may be required.

Note: Conical side up

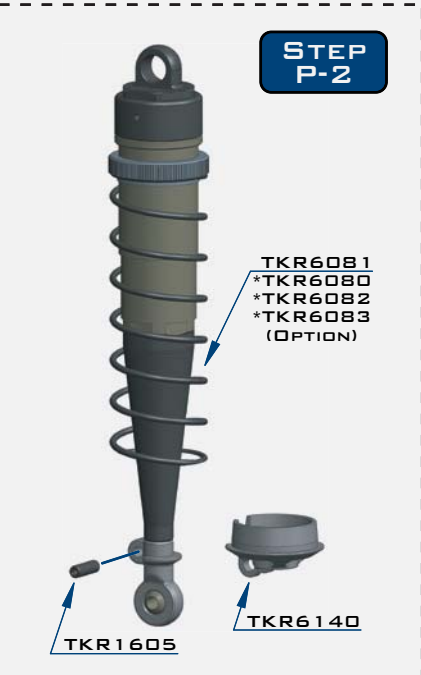
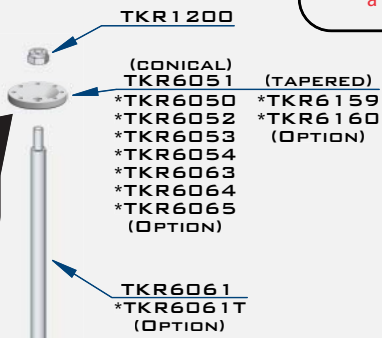

STEP P-2

Note: Use green slime or oil on shock shaft threads AND O-rings to prevent tearing and leaking.



Fill oil level just below the top of the shock body. Use #600wt oil REAR

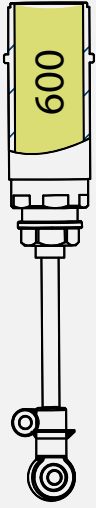

Note: Apply a small drop of oil for easy installation.

Note: Rear shocks use longer shock bodies - TKR6060, longer shock shafts - TKR6061, longer springs - TKR6081 and longer shock boots - TKR6145

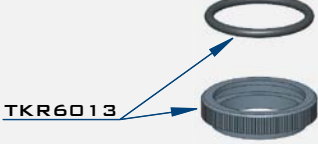

x2
TKR1200
M2.5 LOCK NUT ZINC

x2
TKR1202
M4 LOCK NUT BLACK

x2
TKR1211
M3 LOCK NUT FLANGE BLACK

x2
TKR1529
M3x20MM CAP HEAD SCREW

x2
TKR1605
M3x10MM SET SCREW

STEP P-3

Note: Tighten TKR1211 lock nut all the way down, then back off 1/4 turn. Use thread lock!

* Thread Lock

- Stock shock position is outside hole on the arm and 2nd from outside hole on the tower
- Stock rear ride height 40mm
- Shock length (droop) 136mm

Note: Slot in spring perch should face outside of vehicle.

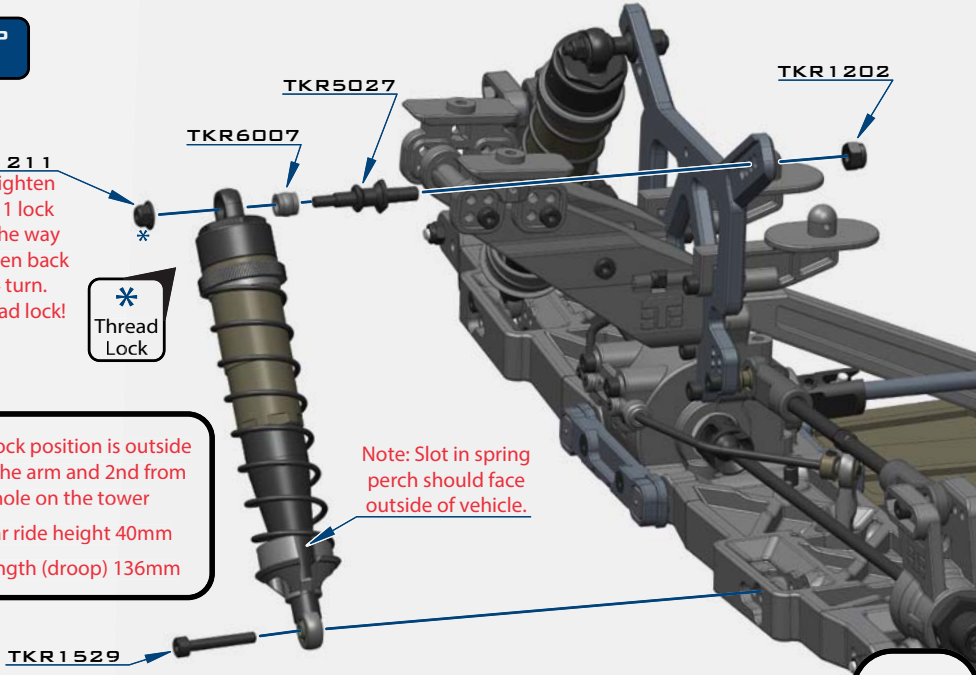

BAG Q

RX TRAY MUD GUARD

STEP Q-1

TKR1525
TKR1221
Note: we recommend using a servo with at least 300 oz/in torque.

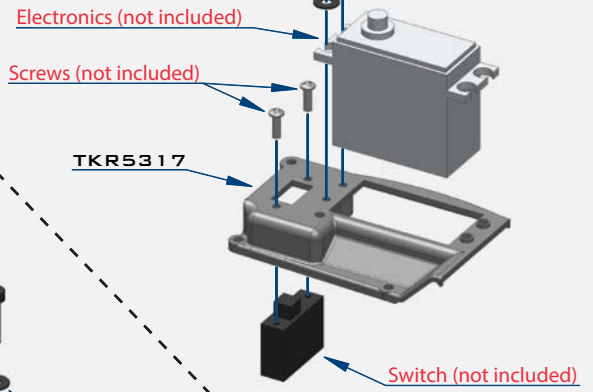

STEP Q-2

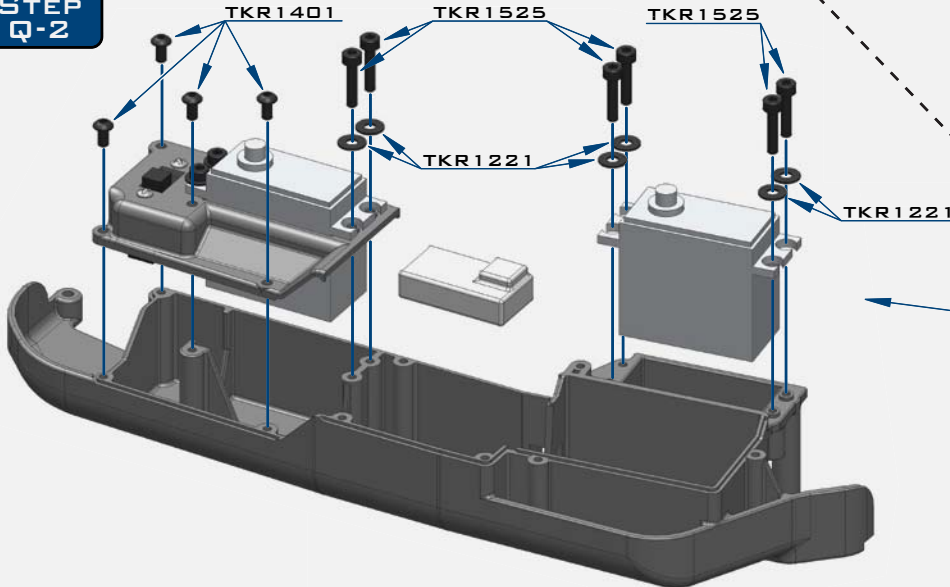

Note: We recommend using a piece of thin foam or other type of padding under the battery to reduce shock. Likewise, we suggest either using a couple layers of 2-sided tape under the receiver or simply use another piece of foam and let the receiver 'float' in the box. The servo wires will help keep the receiver in place and provide shock protection.

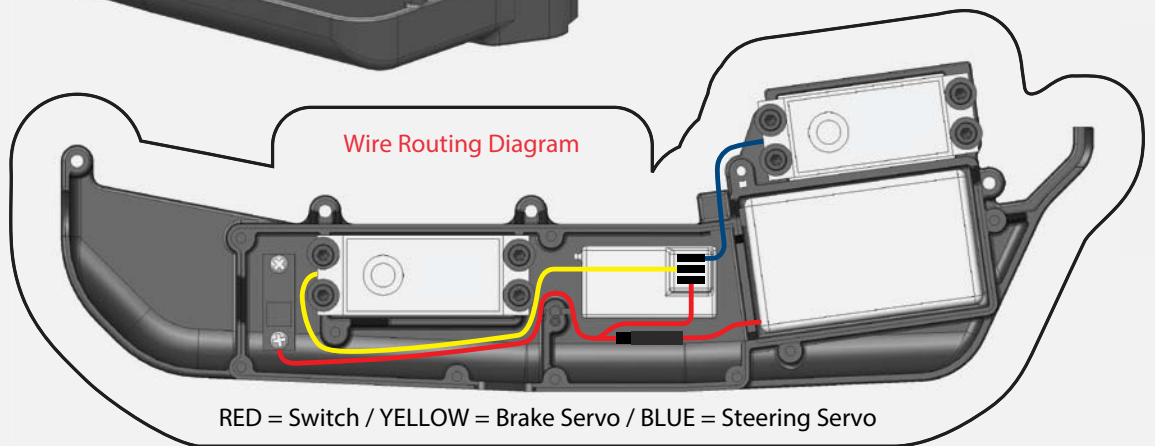

STEP Q-3

Antenna tube installation

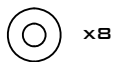
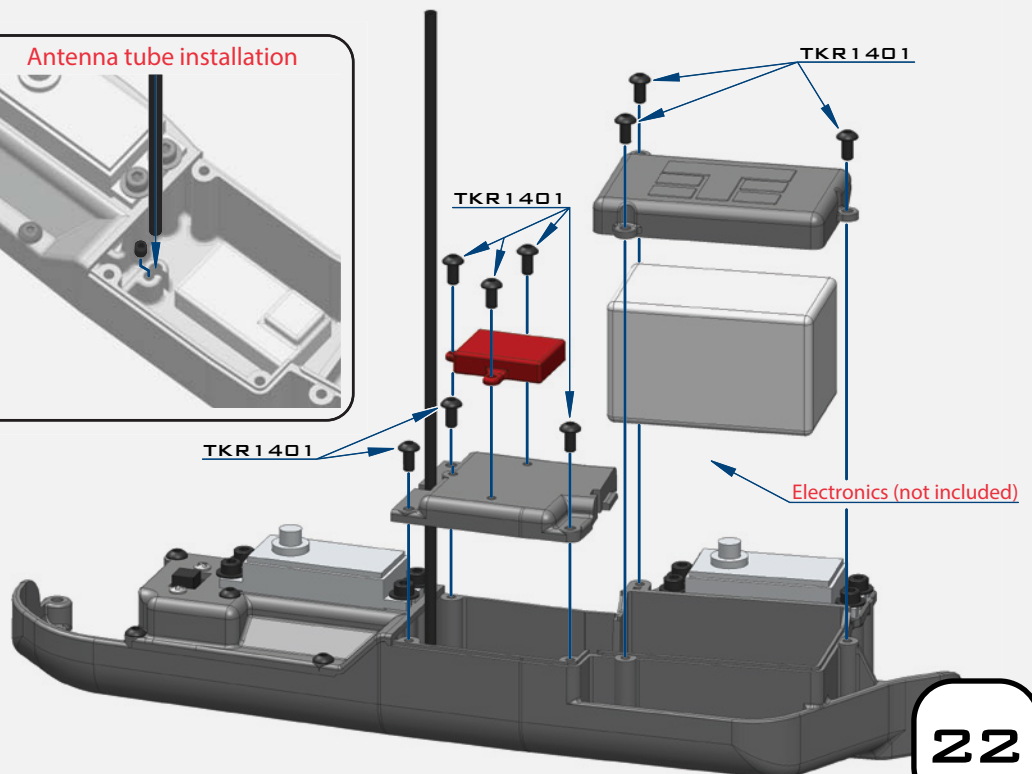
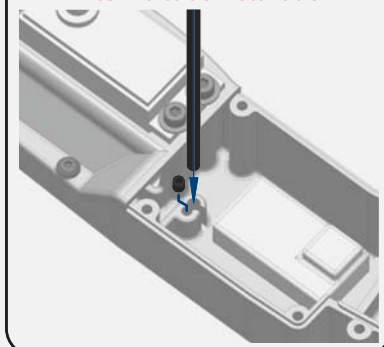

x8

TKR1221
M3X8MM WASHER

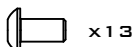

x13

TKR1401
M3X6MM BUTTON HEAD SCREW

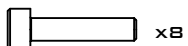

x8

TKR1525
M3X14MM CAP HEAD SCREW



TKR1601
M3X4MM SET SCREW

BAG Q

MUD GUARD INSTALLATION

Note: Do not overtighten radio tray screws.

STEP
Q-4

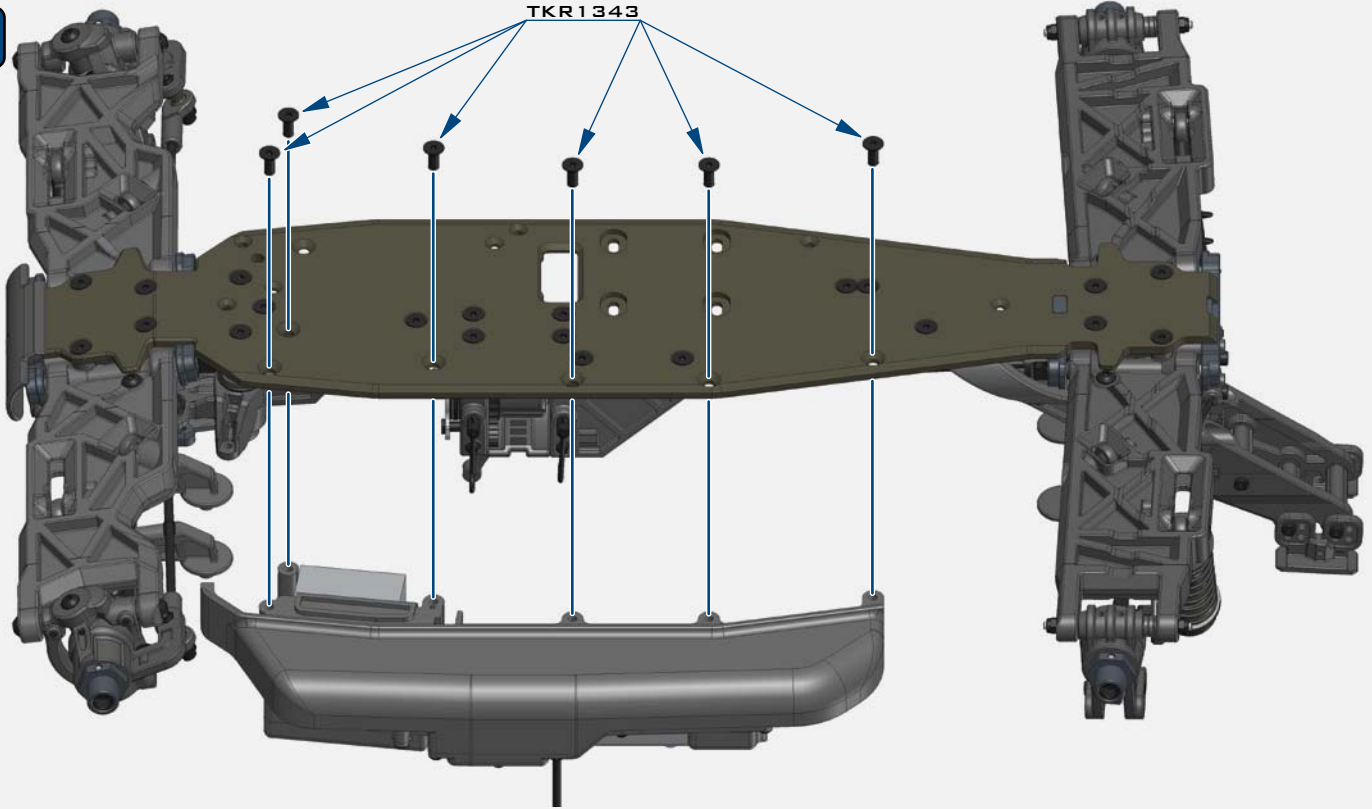

STEP
Q-5

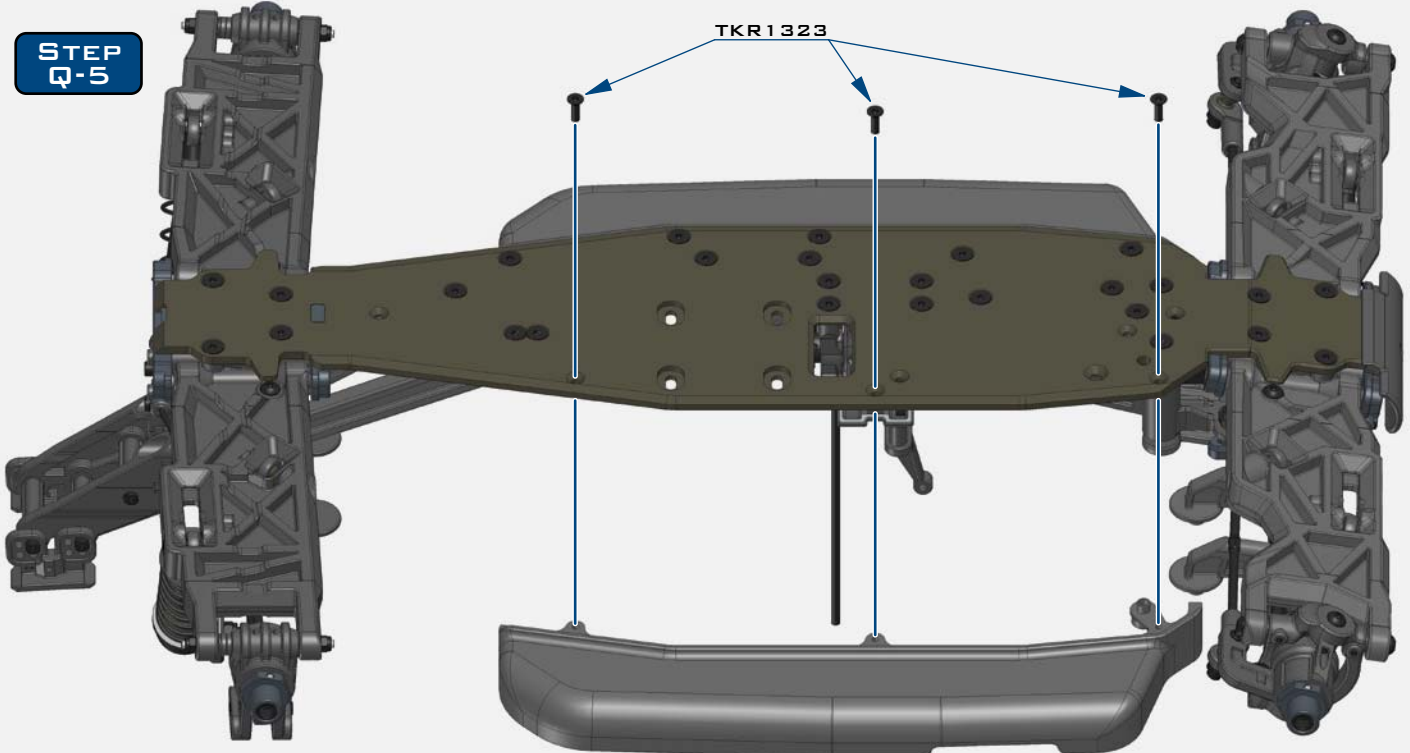

Note: Do not overtighten radio tray screws.

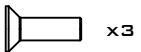

TKR1323
M3X10MM FLAT HEAD SCREW

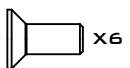

TKR1343
M4X10MM FLAT HEAD SCREW

BAG R

AIR FILTER / CLUTCH

STEP R-1

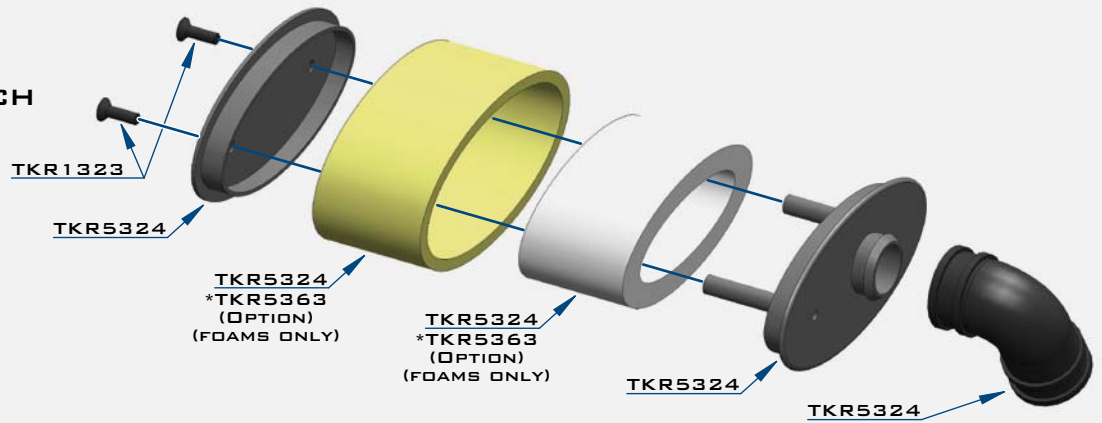

Note: Your kit contains 3 sets of clutch springs. 0.9mm (green), 1.0mm (gold), and 1.1mm (red) springs are included. The stock setting is to use (2x) 1.0mm springs on opposing shoes and then use (2x) 1.1mm springs on the other shoes. If the track is very high bite you can use (4x) 1.1mm springs for more 'pop'. However, we strongly recommend trying the stock setting first and adjusting from there.

STEP R-2

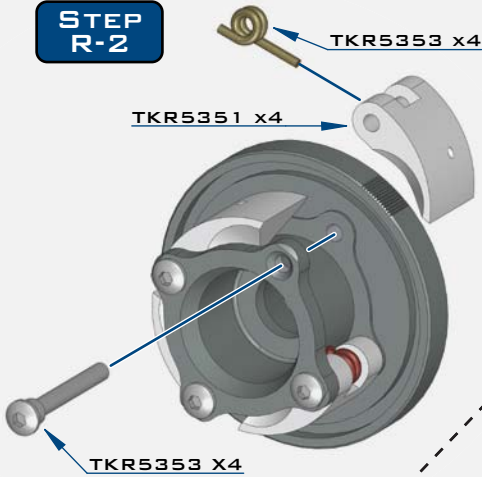

STEP R-3

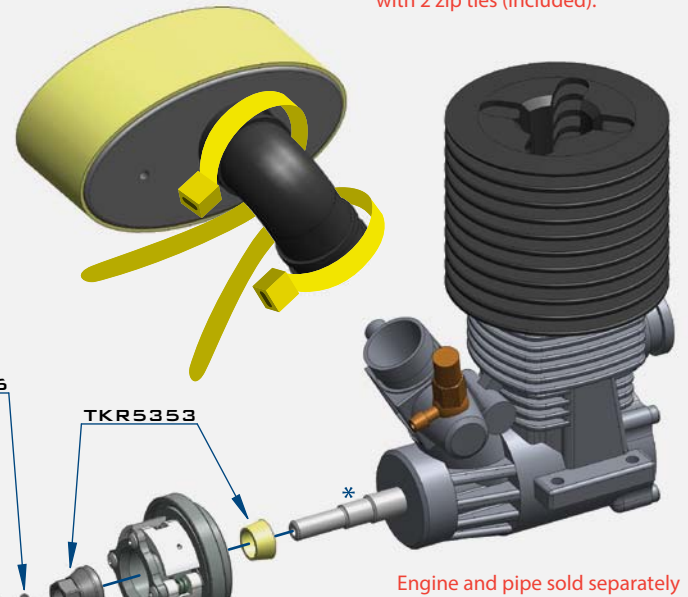

Note: Secure air filter hose with 2 zip ties (included).

Engine and pipe sold separately

Note: Properly shimming the clutch bell is critical. The clutch bell must not rub on the flywheel. Depending on your particular engine, you may need to use a few of the 5x7x0.2mm shims (TKR1226) to properly space the clutch bell. The clutch bell must also move freely when the end washer and screw are fastened. There is no 'one size fits all' for the number and order of clutch bell shims that need to be used. In rare cases, the clutch bell may be too long. Simply put the clutch bell flat on a sheet of 200 grit sand paper (teeth side up) and sand about .2mm off the bottom. This should only take a minute and it will ensure that your clutch is working properly.



 x4
TKR1226
5x7x0.2MM SHIM

 x3
TKR1323
M3x10MM FLAT HEAD SCREW

 x4
TKR5353
CLUTCH PIN

 x1
TKRBB05104
BALL BEARING (5x10x4)

 x1
TKRBB05134
BALL BEARING (5x13x4)

STEP R-4

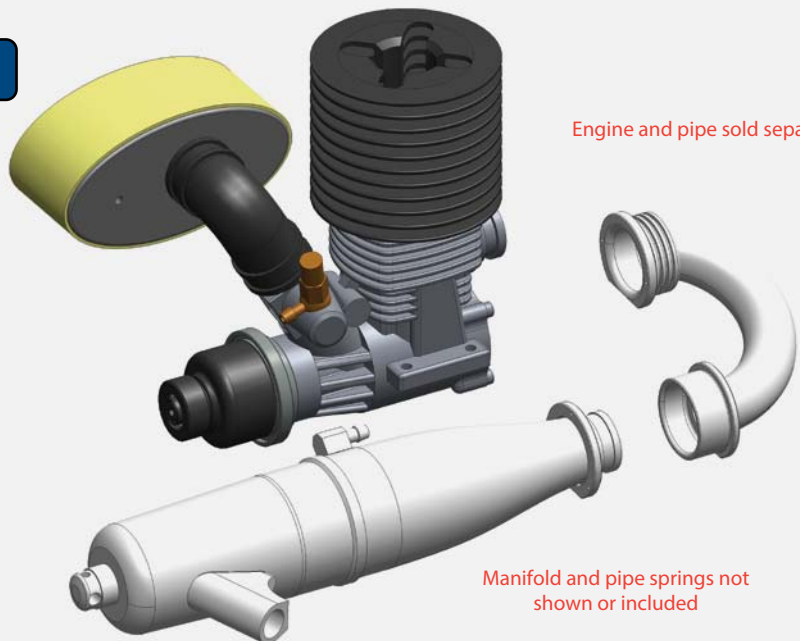

Engine and pipe sold separately

Manifold and pipe springs not shown or included

BAG S

ENGINE / PIPE INSTALLATION

STEP S-1

VERY IMPORTANT - With the set screws that secure the pipe hanger wire set loose, install pipe onto pipe hanger wire. Adjust the wire such that the pipe and the manifold connections from the engine are not bent or angled. The pipe must fit naturally. You may need to bend the pipe hanger wire to accomplish this. Then tighten the set screw that secures the wire to the wire hanger block. The wire must then be cut flush to the wire hanger block so it will not interfere with the fuel tank. If the wire is not flush with the block, you may risk puncturing your fuel tank.



*You may need to bend the pipe wire hanger forward or backward depending on your particular pipe.

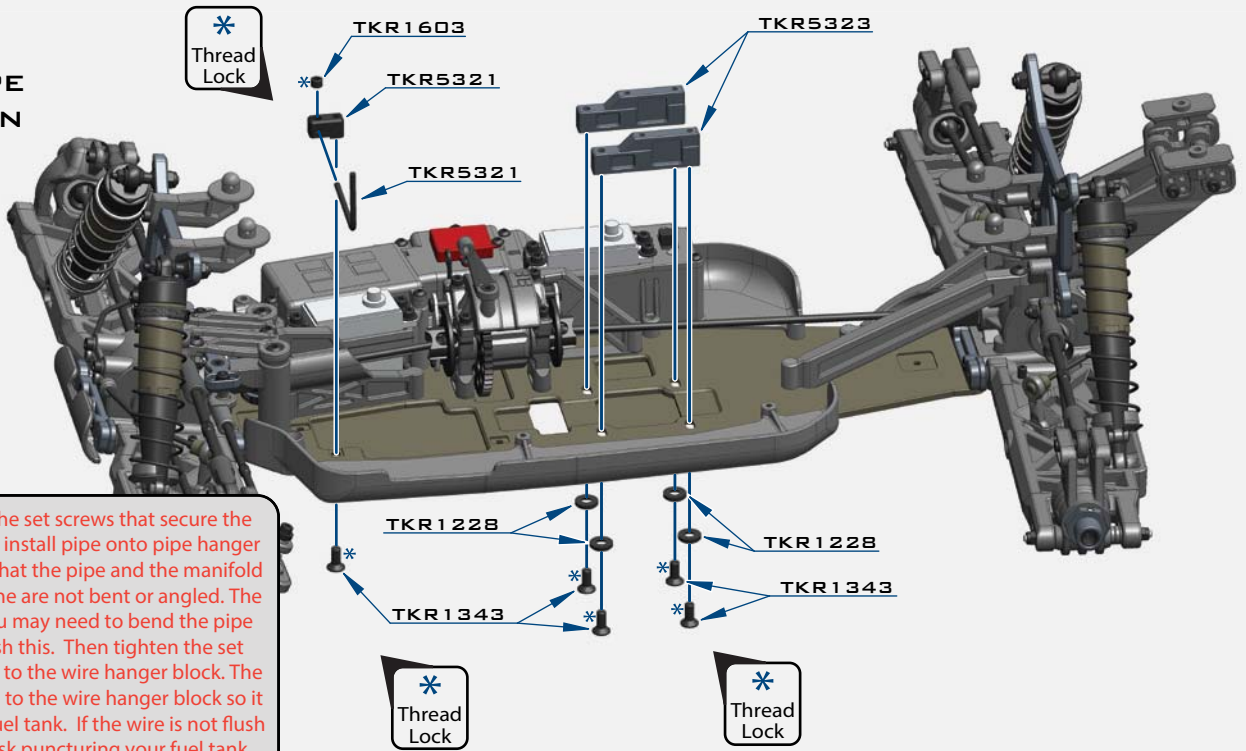

STEP S-2

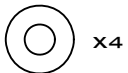
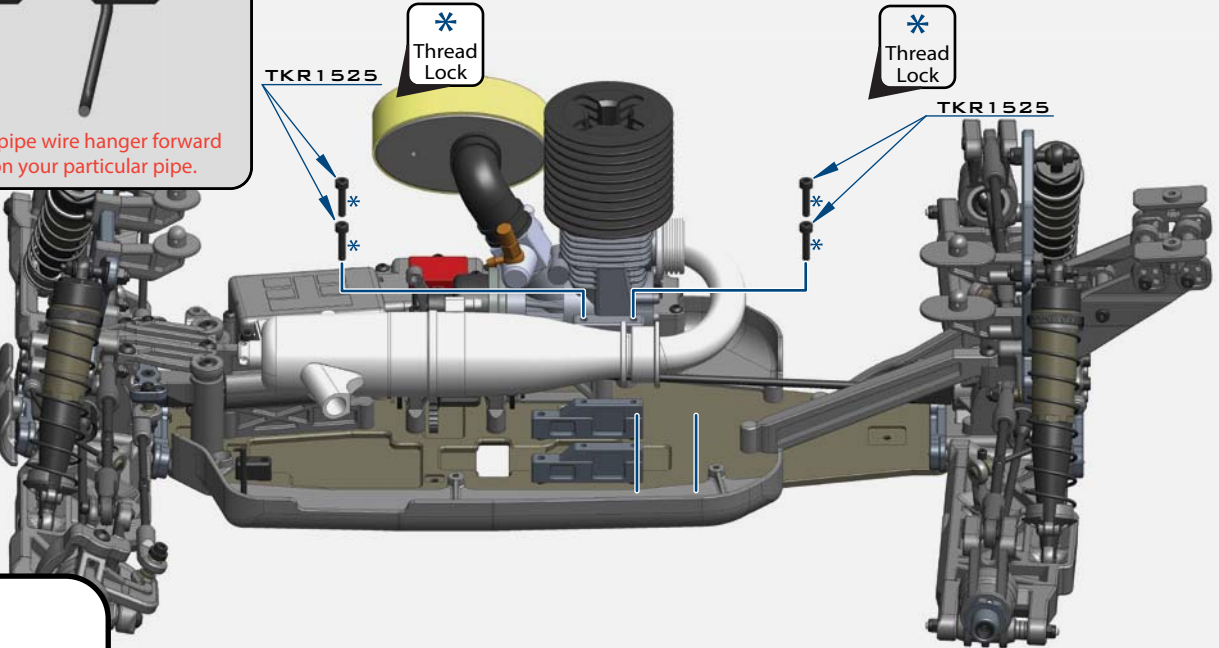

x4

TKR1228
M4 COUNTERSUNK WASHER



x5

TKR1343
M4X10MM FLAT HEAD SCREW

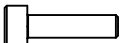

x1

TKR1524
M3X12MM CAP HEAD SCREW

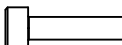

x4

TKR1525
M3X14MM CAP HEAD SCREW



x1

TKR1603
M5X4MM SET SCREW

STEP S-3

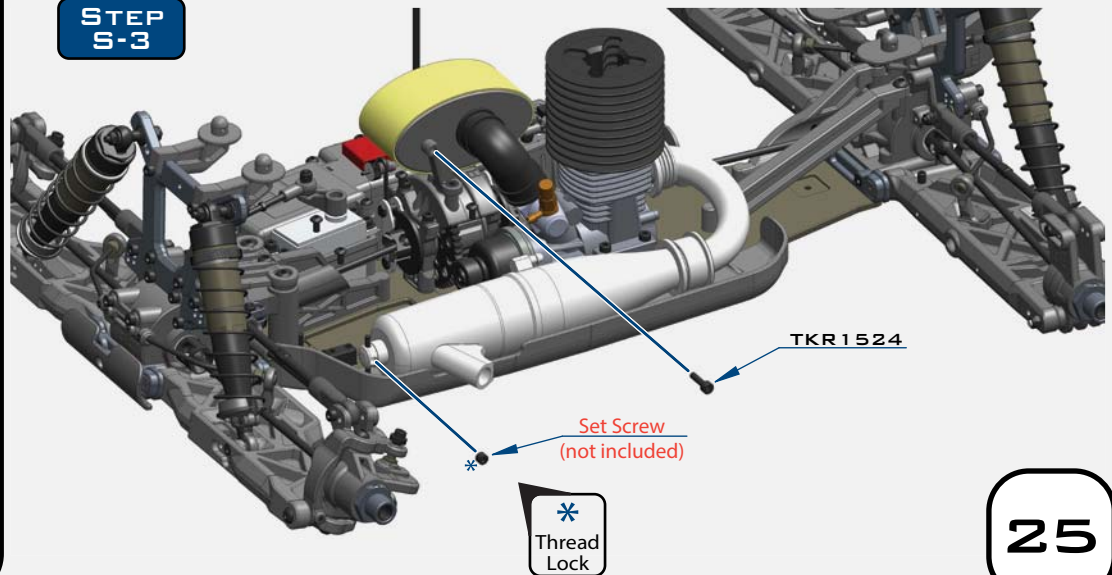

BAG T

STEERING LINKAGE

STEP T-1

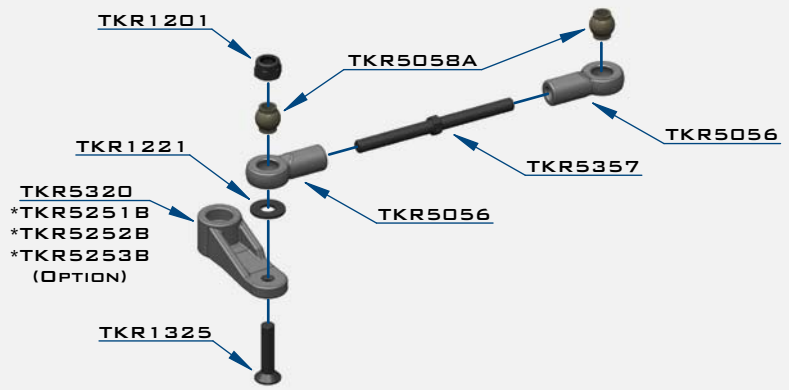

STEP T-2

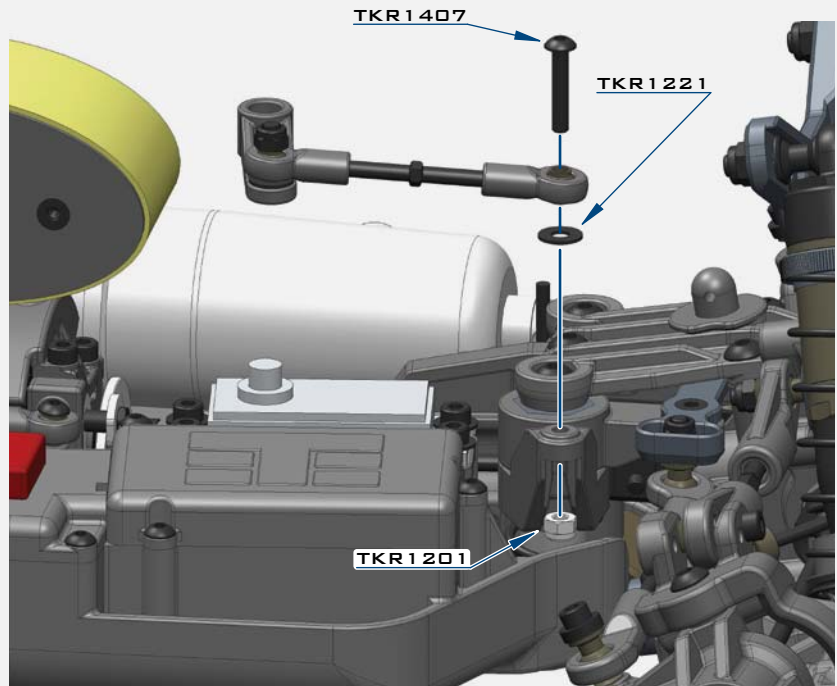

STEP T-3

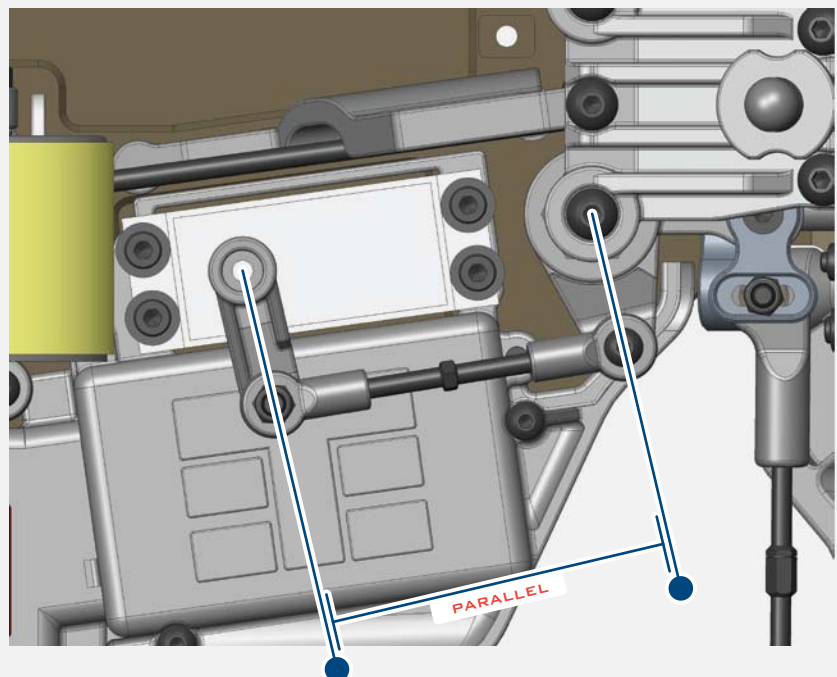

 x2
TKR1201
M3 LOCK NUT BLACK

 x2
TKR1221
M3X8MM WASHER

 x1
TKR1325
M3X14MM FLAT HEAD SCREW

 x1
TKR1407
M3X16MM BUTTON HEAD SCREW

 x2
TKR5058A
PIVOT BALL M3X5.8MM
NO FLANGE

Note: Offset servo arm so it is parallel with the connecting arm at neutral or zero servo position.

BAG T

BRAKE LINKAGE

STEP T-4

Note: This rod has small threaded section

BEFORE

AFTER

Note: Set collars up to appear close to this diagram.

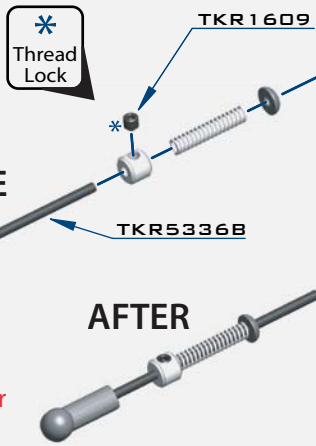

STEP T-5

* Thread Lock

Note: TKR5336B should spin freely.

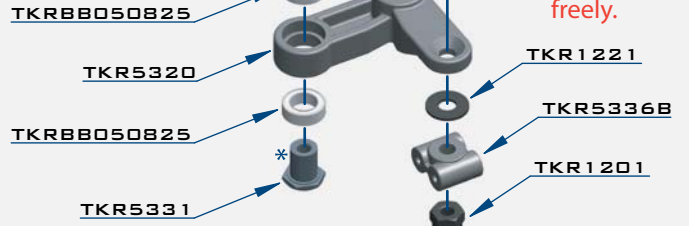

STEP T-6

* Thread Lock

Note: Set collars up to appear close to this diagram.

BEFORE

AFTER

Note: Leave 2mm space

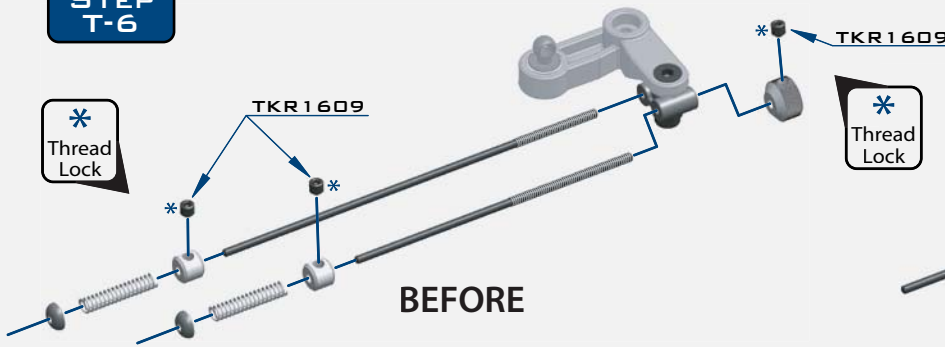

STEP T-7

* Thread Lock

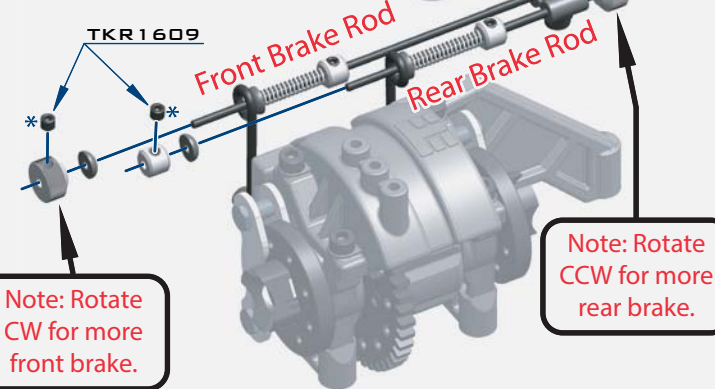

Note: Rotate CW for more front brake.

Note: Rotate CCW for more rear brake.

STEP T-8

TKR1609

* Thread Lock

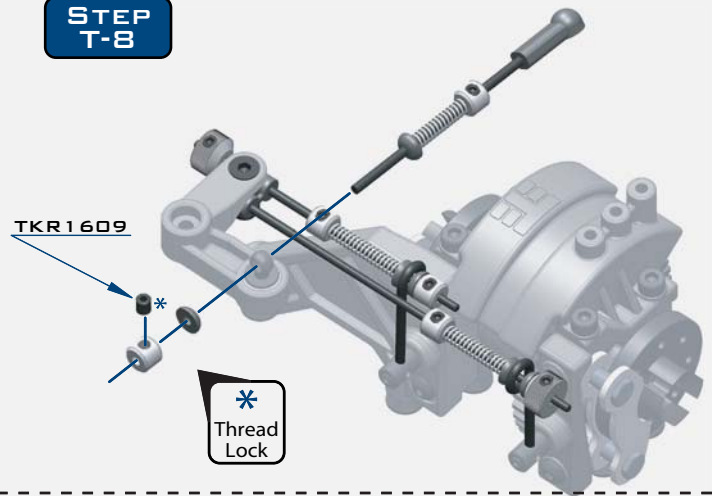

STEP T-9



TKR1201
M3 LOCK NUT BLACK



TKR1221
M3x8MM WASHER

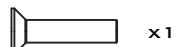

TKR1325
M3x14MM FLAT HEAD SCREW



TKR1609
M3x3MM SET SCREW



TKRBB050825
BALL BEARING (5x8x2.5)

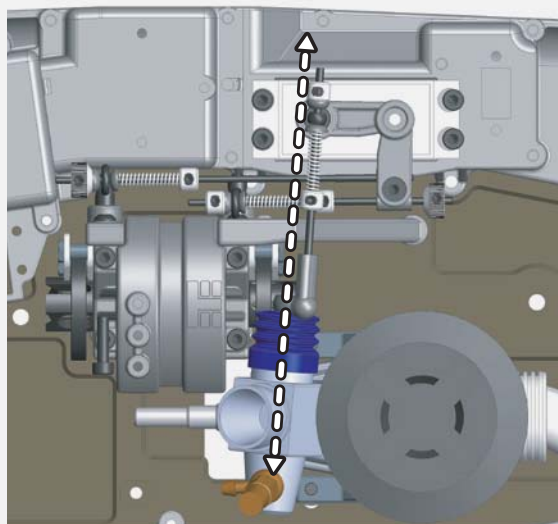

NOTES:

- Align the carburetor so it forms a straight line to the servo linkage, with the servo in the neutral position
- Attach all linkages before setting brake bias
- All collars should be snug against the springs without being compressed
- Turn on radio equipment for final adjustment of collars, total brake force, F/R brake bias, and throttle EPA
- Brakes should be fully disengaged and the carburetor should be fully closed at neutral position

BAG U

FUEL TANK

STEP U-1

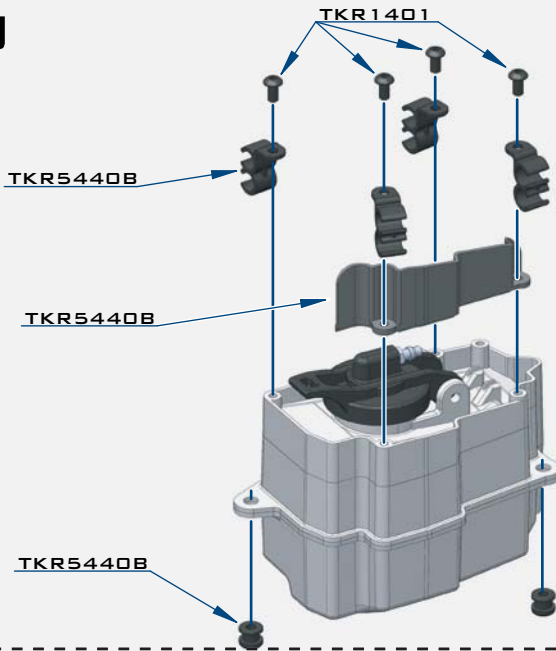

STEP U-2

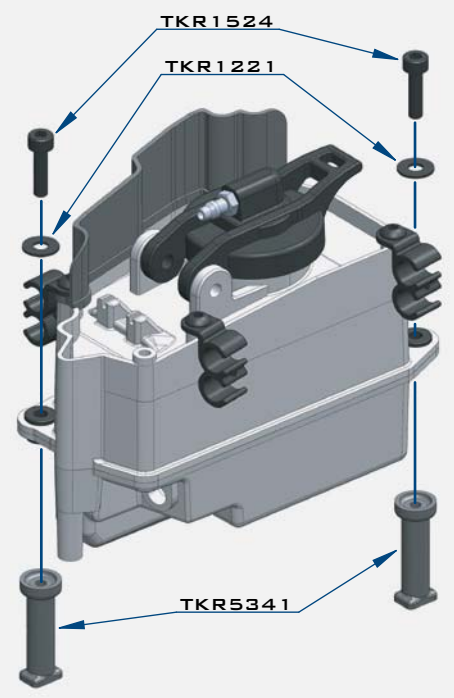

STEP U-3

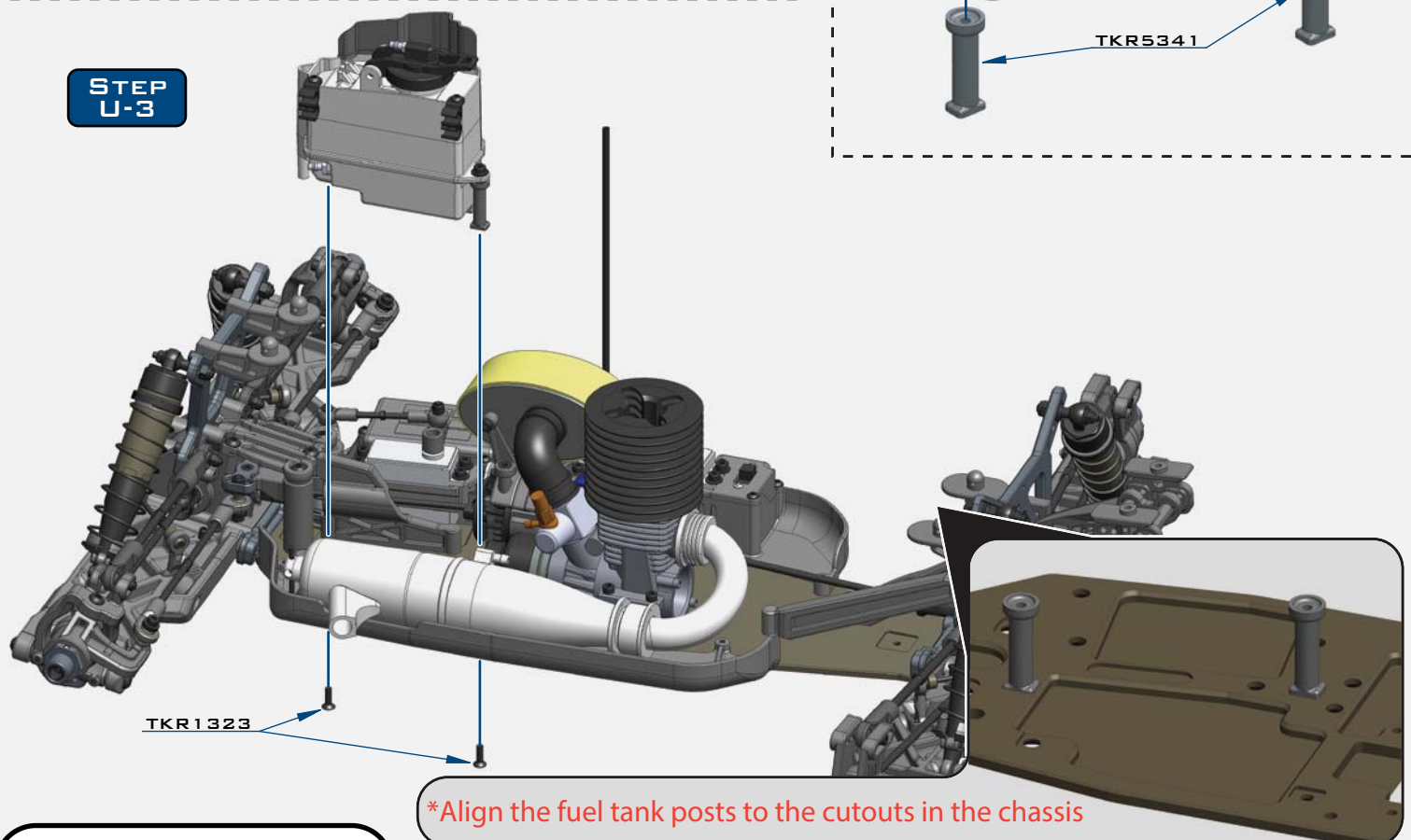

 x2
TKR1221
M3X8MM WASHER

 x2
TKR1323
M3X10MM FLAT HEAD SCREW

 x4
TKR1401
M3X6MM BUTTON HEAD SCREW

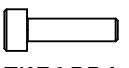
 x2
TKR1524
M3X12MM CAP HEAD SCREW

STEP U-4

Note: Fuel tubing wraps around the tank 1 1/2 times from the pick up nipple (yellow line). Pressure line is shown in blue.

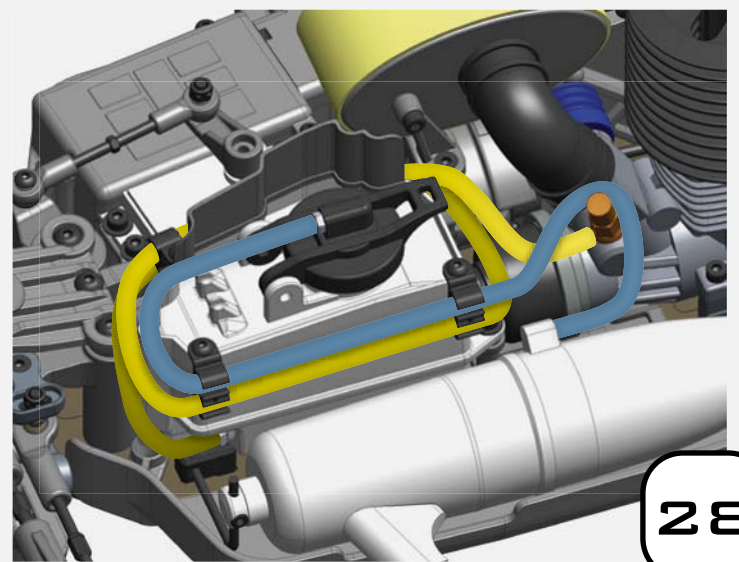

BAG V

WING AND BODY

STEP V-1

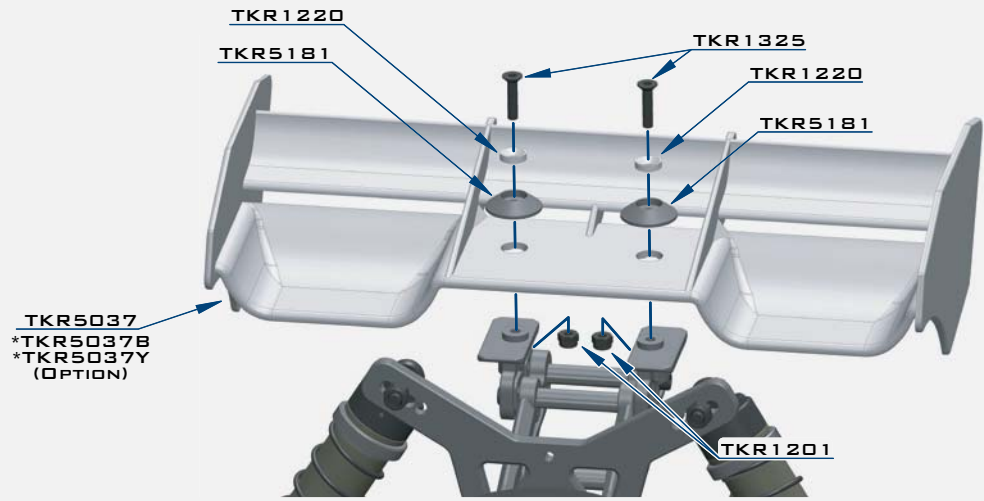

STEP V-2

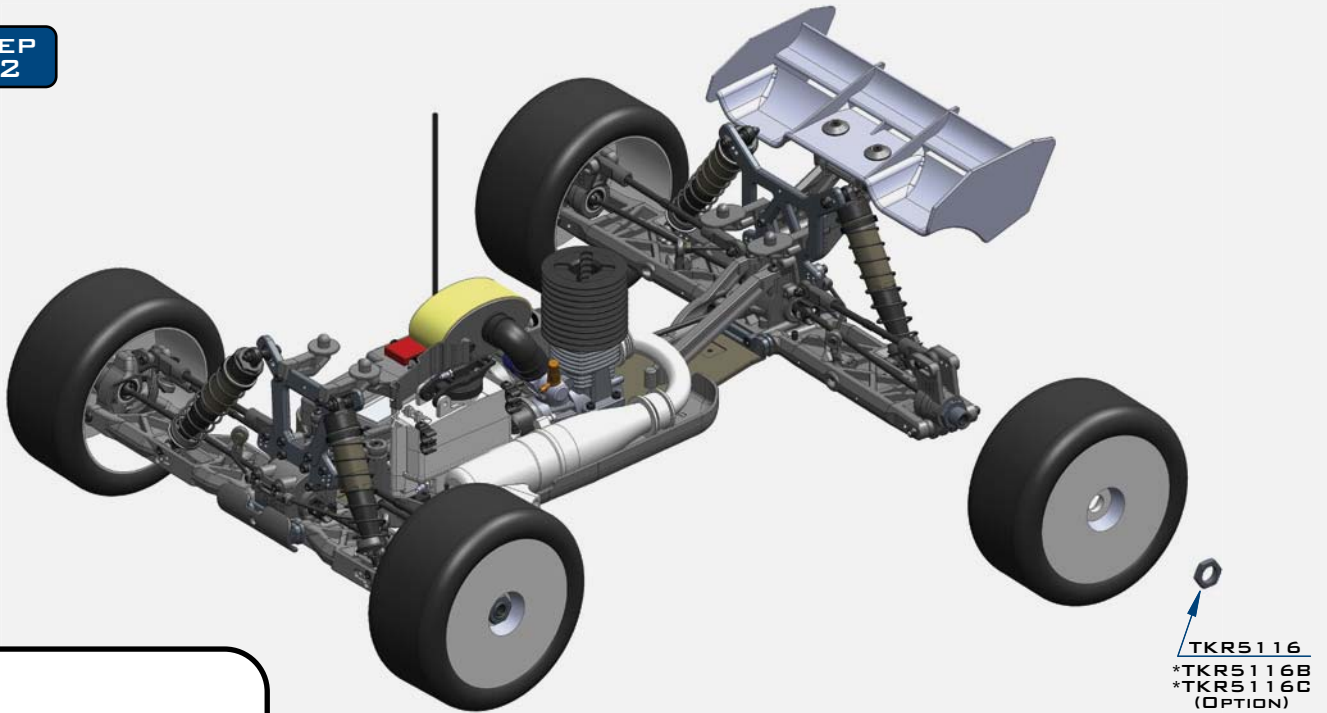

x2
TKR1201
M3 LOCK NUT BLACK



x2
TKR1220
M4 COUNTERSUNK WASHER

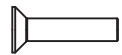

x2
TKR1325
M3X14MM FLAT HEAD SCREW



x2
TKR1235
BODY CLIP

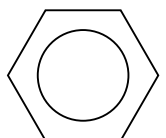

x4
TKR5116
WHEEL NUT

STEP V-3

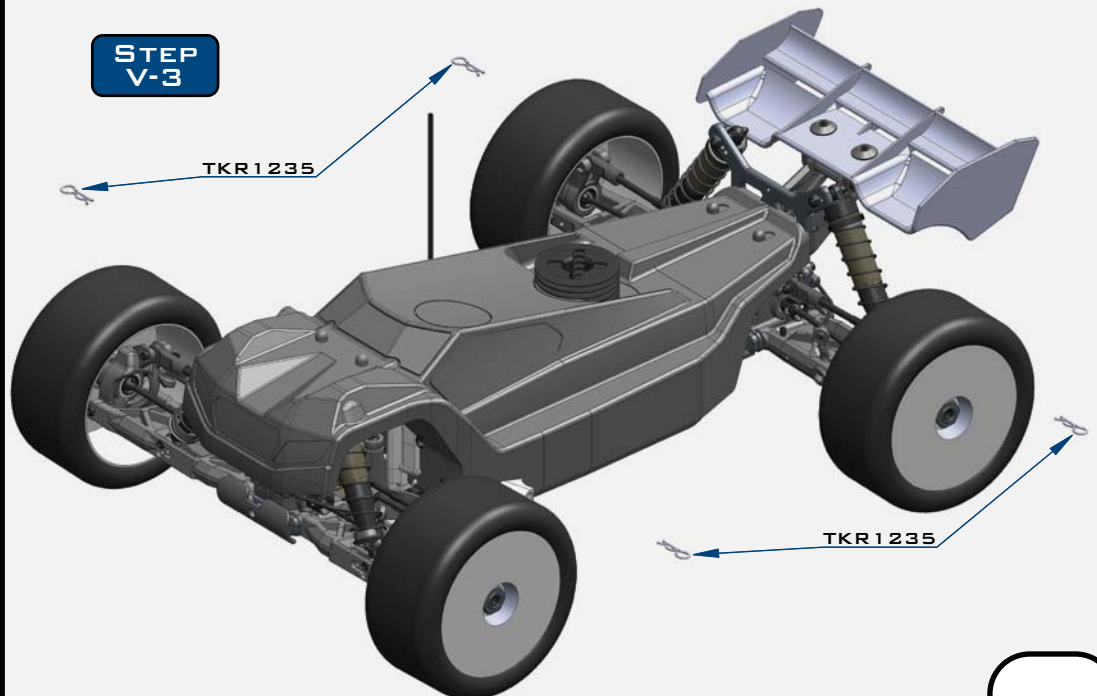

TKR5406 - NT48.3 1/8th Competition Nitro Truggy Kit

Parts List

TKR4213 - Clutch Bell (13t, NT48)
TKR5012 - Gearbox (front)
TKR5020 - Hinge Pins (inner, front/rear)
TKR5027 - Shock Standoffs (2pcs)
TKR5034 - Hinge Pins (outer, rear)
TKR5037 - Wing (white)
TKR5049A - Pivot Balls (6.8mm, no flng, sway bar, shck ends, almmn, 4pcs)
TKR5052A - Pivot Balls (6.8mm, inside camber, steering links, aluminum, 4pcs)
TKR5053A - Pivot Balls (6.8mm, flanged, outside camber, aluminum, 4pcs)
TKR5054A - Spindle Bushings (4pcs, aluminum, hard ano)
TKR5055A - Arm Bushings (4pcs, aluminum, hard ano)
TKR5056 - Rod Ends (5.8mm, brake/steering/sway bar linkage, 8pcs)
TKR5058A - Pivot Balls (5.8mm, no flange, brake/steering link, aluminum, 4pcs)
TKR5070 - Stub Axles (hardened steel, 2pcs)
TKR5071 - Wheel Hubs (17mm, aluminum, w/pins, 2pcs)
TKR5073 - CV Rebuild kit (f/r, for 2 axles)
TKR5075 - Diff Coupler (f/r, hardened steel)
TKR5079A - Stabilizer Balls (6.8mm, sway bars, aluminum, 4pcs)
TKR5086 - Sway Bar Mounts
TKR5100 - Ackerman Plate (aluminum, gun metal ano)
TKR101X - Servo Saver Spring (HD, EB48, SCT410, NB48)
TKR5102A - Steering Posts (aluminum)
TKR5103 - Servo Saver Post (aluminum, gun metal ano)
TKR5104 - Steering Bell Cranks
TKR5107 - Steering Top Plate, Center Diff Top Plate, Center Diff Rear Support
TKR5116 - Wheel Nuts (17mm, serrated, gun metal ano, M12x1.0, 4pcs)
TKR5122 - Steering Rack Bushings (aluminum, gun metal ano, 2pcs)
TKR5126 - Antenna tube (universal, w/ caps, 5pcs)
TKR5161 - V2 Adj. Hinge Pin Brace ("A" block, 7075, EB/NB/ET/NT/SCT)
TKR5162 - V2 Adj. Hinge Pin Brace ("B" block, 7075, EB/NB/ET/NT/SCT)
TKR5163 - V2 Adj. Hinge Pin Brace ("C" block, 7075, EB/NB/ET/NT/SCT)
TKR5164 - V2 Adj. Hinge Pin Brace ("D" block, 7075, EB/NB/ET/NT/SCT)
TKR5165 - V2 Hinge Pin Inserts, Wheelbase Shims (EB/NB/ET/NT/SCT)
TKR5166 - Front Bumper (revised, EB/NB/ET/NT48)
TKR5181 - Low Profile Wing Mount and Body Mounts (EB/NB48/EB48SL)
TKR5187 - Rod Ends (straight, 6.8mm, EB/NB/ET/NT48, 8pcs)
TKR5193 - Spindles (trailing, L/R, requires TKR5194, EB/NB/ET/NT48, EB/NB.3)
TKR5194 - Spindle Carriers (trailing, 15 degree, L/R, EB/NB/ET/NT48, EB/NB.3)
TKR5199 - Rear Hubs (L/R, CV or uni, EB/NB/ET/NT48, EB/NB.3)
TKR5213A - Brake Posts (aluminum, 4pcs)
TKR5215B - Brake Cams (10 deg, steel, 2pcs)
TKR5231 - Servo Saver Nut and Spring
TKR5310 - Center Differential Mount (NB48, NT48)
TKR5314B - Brake Pad Set (2pcs, NB/NT)
TKR5316 - Rear GearBox (offset, rear, NB48, NT48)
TKR5317 - Radio Tray and Mud Guard Set (left/right side, NB48, NT48)
TKR5319 - Radio Tray Covers (NB48, NT48)
TKR5320 - Servo Horns (steering, throttle, NB48, NT48)
TKR5321 - Exhaust Wire Mount Set (CNC, NB48, NT48)
TKR5323 - Engine Mounts (CNC, NB48, NT48)
TKR5324 - Air Filter Set (hose, filter, housing, NB48, NT48)
TKR5331 - Throttle Pivot Ball Assembly (CNC, NB48, NT48)
TKR5336B - Throttle, Brake Linkage (NB/NT, revised)
TKR5341 - Fuel Tank Post and Air Filter Hanger Set (NB48, NT48)
TKR5345B - Brake Disc (steel, NB/NT, revised, 1pc)
TKR5350 - Flywheel (4-shoe)
TKR5351 - Clutch Shoes (7075, 4pcs, NB48, NT48)
TKR5353 - Clutch Springs and Hardware Set (NB48, NT48)
TKR5357 - Steering Servo Turnbuckle (NB48, NT48)
TKR5362 - Chassis Brace Set (NB48, NT48)
TKR5363 - Air Filter Foams (inner, outer, pre-oiled, 3pcs each, NB48, NT48)
TKR5368 - Brake Post Spring (NB/NT, 4pcs)
TKR5377 - Driveshaft (center, front, steel, NB48, NT48)
TKR5401 - Body Mount Set (ET48, NT48)
TKR5407 - Chassis (7075, 4mm, hard anodized, lightened, NT48.3)
TKR5417 - Decal Sheet (NT48.3)
TKR5423 - Turnbuckle (steering links, 2pcs, ET48, NT48)
TKR5428 - Shock Tower (front, 7075, gun metal, ET48, NT48)
TKR5429 - Shock Tower (rear, 7075, gun metal, ET48, NT48)
TKR5430 - Suspension Arms (rear, 2pcs, ET48, NT48)
TKR5436 - Suspension Arms (front, 2pcs, ET48, NT48)
TKR5440B - Fuel Tank (w/ clunk, NT48, revised)
TKR5445 - Body (NT48, w/ window mask)
TKR5450 - Turnbuckle (camber link, rear, 2pcs, ET48, NT48)
TKR5451 - Turnbuckle (camber link, front, 2pcs, ET48, NT48)
TKR5472 - Driveshafts (f/r, hardened steel, 2pcs, ET48, NT48)
TKR5476 - Driveshaft (center, rear, steel, NT48)
TKR5482 - Sway Bar (front, 2.5mm, ET48, NT48)
TKR5493 - Sway Bar (rear, 2.6mm)

Differential List

TKR5112X - Differential Outdrives (center, lightened)
TKR5113 - Differential Case (f/c/r)
TKR5114X - Differential Outdrives (f/r, lightened)
TKR5119 - Spur Gear (46t, steel)
TKR5143 - Differential Seals (3pcs)
TKR5144 - Differential O-Rings (6pcs)
TKR5145B - Differential Shims (revised, 6x17mm, 6pcs)
TKR5149 - Differential Cross Pins (steel, 6pcs)
TKR5150 - Differential Gear Set (internal gears only)
TKR5403 - Differential Ring Gear (40t, NT48 fr, ET48 fr/r)
TKR5404 - Differential Ring Gear (40t, rear, CNC, NT48)
TKR5405 - Diff Pinion (straight cut, 9t, CNC, NT48)

Bearings List

TKRBB050825 - Ball Bearing (5x8x2.5mm, 4pcs)
TKRBB05104 - Ball Bearing (5x10x4, 4pcs)
TKRBB05114 - Ball Bearing (5x11x4, 4pcs)
TKRBB05134 - Ball Bearing (5x13x4, 4pcs)
TKRBB06103 - Ball Bearing (6x10x3, 4pcs)
TKRBB08165 - Ball Bearing (8x16x5, 4pcs)
TKRBB13194 - Ball Bearing (13x19x4, 4pcs)

Shocks List

TKR6003B - Non-Vented Shock Caps (aluminum, black ano, 2pcs)
TKR6007 - Shock Cap Bushings (4pcs, EB/NB/ET/NT/SCT)
TKR6008 - Shock Shaft Guide, Piston, and Bushing Set (for 2 shocks)
TKR6009 - Shock O-Ring and Bladder Set (for 2 shocks)
TKR6013 - Shock Adjustment Nuts (aluminum, gun metal ano, 2pcs)
TKR6015 - Shock Cartridge Caps (aluminum, gun metal ano, 2pcs)
TKR6016 - Shock Body (rear, aluminum, hard ano, 2pcs)
TKR6017 - Shock Shafts (rear, steel, 2pcs)
TKR6051 - Shock Pistons (CNC, conical, 8x1.3mm)
TKR6060 - Shock Body (rear, x-long, aluminum, hard ano, 2pcs)
TKR6061 - Shock Shafts (rear, x-long, steel, 2pcs)
TKR6081 - Shock Spring Set (rear, 1.6 x 10.0T, 90mm, green, 4.20 lb/in)
TKR6091 - Shock Spring Set (front, 1.6 x 8.5T, 80mm, green, 5.17 lb/in)
TKR6140 - Locking Shock Rod End and Spring Perch Set (EB/NB/ET/NT/SCT)
TKR6144 - Shock Boots (long length, EB/NB, 2pcs)
TKR6145 - Shock Boots (X-long length, rear EB/NB, 2pcs)

Hardware List

TKR1200 - M2.5 Locknuts (zinc finish, 10pcs)
TKR1201 - M3 Locknuts (black, 10pcs)
TKR1202 - M4 Locknuts (black, 10pcs)
TKR1211 - M3 Locknuts (flanged, black, 10pcs)
TKR1220 - M3 Countersunk Washers (aluminum, natural, 10pcs)
TKR1221 - M3x8mm Washer (black, 10pcs)
TKR1222 - 13x16x1.1mm Diff Shims (10pcs)
TKR1226 - 5x7x2mm shims (10pcs)
TKR1228 - M4 Countersunk Washer (black, 10pcs)
TKR1235 - Body Clips (10pcs)
TKR1238 - Droop Adjustment Screws (M4x10mm, 8pcs)
TKR1322 - M3x8mm Flat Head Screws (black, 10pcs)
TKR1323 - M3x10mm Flat Head Screws (black, 10pcs)
TKR1325 - M3x14mm Flat Head Screws (black, 10pcs)
TKR1327 - M3x16mm Flat Head Screws (black, 10pcs)
TKR1333 - M3x40mm Flat Head Screws (black, 10pcs)
TKR1343 - M4x10mm Flat Head Screws (black, 10pcs)
TKR1344 - M4x12mm Flat Head Screws (black, 10pcs)
TKR1401 - M3x6mm Button Head Screws (black, 10pcs)
TKR1402 - M3x8mm Button Head Screws (black, 10pcs)
TKR1407 - M3x16mm Button Head Screws (black, 10pcs)
TKR1443 - M4x10mm Button Head Screws (black, 10pcs)
TKR1445 - M4x14mm Button Head Screws (black, 10pcs)
TKR1447 - M4x16mm Button Head Screws (black, 10pcs)
TKR1522 - M3x8mm Cap Head Screws (black, 10pcs)
TKR1524 - M3x12mm Cap Head Screws (black, 10pcs)
TKR1525 - M3x14mm Cap Head Screws (black, 10pcs)
TKR1529 - M3x20mm Cap Head Screws (black, 10pcs)
TKR1601 - M3x4mm Set Screws (black, 10pcs)
TKR1603 - M5x4mm Set Screws (black, 10pcs)
TKR1605 - M3x10mm Set Screws (black, 10pcs)

Option Parts

TKR1103 - Turnbuckle Wrench (4mm, 5mm, hardened steel)
TKR1115 - Pivot Ball and Shock Multi-tool (aluminum)
TKR1116 - 17mm Wheel Wrench, Shock Cap Tool
TKR1119 - 5.5mm / 7.0mm Wrench (hardened steel)
TKR5037B - Wing (black)
TKR5037Y - Wing (yellow)
TKR5070A - Stub Axles (Aluminum, 2pcs)
TKR5071B - Wheel Hubs (17mm, alum, ltnd, gun metal ano, 1mm off, w/pins, 2pcs)
TKR5071C - Wheel Hubs (17mm, alum, ltnd, gun metal ano, 2mm off, w/pins, 2pcs)
TKR5071X - Wheel Hubs (17mm, aluminum, lightened, gun metal ano, w/pins, 2pcs)
TKR5149A - Diff Cross Pins (aluminum, 6pcs, requires TKR5150)
TKR5199A - Aluminum Rear Hubs (gun metal ano, EB/NB/ET/NT, 2pcs)
TKR5251B - Aluminum Servo Horn (23t spline, M3 clamp, double hole)
TKR5252B - Aluminum Servo Horn (24t spline, M3 clamp, double hole)
TKR5253B - Aluminum Servo Horn (25t spline, M3 clamp, double hole)
TKR5377A - Driveshaft (center, front, alumin, NB48, NT48)
TKR5433 - Rear Arm Mud Guards (ET48, NT48)
TKR5446 - Complete F/R Differential (ET48 fr/r, NT48 front only)
TKR5447B - Complete Center Differential (NB48.3/NT48.3, 46T spur)
TKR5448 - Complete Rear Differential (NT48)
TKR5476A - Driveshaft (center, rear, aluminum, NT48)
TKR5480 - Sway Bar (front, 2.3mm, ET48, NT48)
TKR5481 - Sway Bar (front, 2.4mm, ET48, NT48)
TKR5483 - Sway Bar (front, 2.6mm, ET48, NT48)
TKR5484 - Sway Bar (front, 2.8mm, ET48, NT48)
TKR5485 - Sway Bar (front, 3.0mm, ET48, NT48)
TKR5490 - Sway Bar (rear, 2.3mm)
TKR5491 - Sway Bar (2.4mm, rear)
TKR5492 - Sway Bar (rear, 2.5mm)
TKR5494 - Sway Bar (rear, 2.8mm)
TKR5495 - Sway Bar (rear, 3.0mm)
TKR6003 - Vented Shock Caps (aluminum, black ano, 2pcs)
TKR6009B - Shock O-Ring Set (16pcs)
TKR6017T - Shock Shafts w/ TiNi coating (rear, steel, 2pcs)
TKR6018 - Shock Cap and Spring Adjuster Set (composite, for 2 shocks)
TKR6050 - Shock Pistons (CNC, conical, 10x1.1mm)
TKR6052 - Shock Pistons (CNC, conical, 10x1.2mm)
TKR6053 - Shock Pistons (CNC, conical, 8x1.4mm)
TKR6054 - Shock Pistons (CNC, conical, 10x1.3mm)
TKR6061T - Shock Shafts w/ TiNi coating (rear, x-long, steel, 2pcs)
TKR6063 - Shock Pistons (CNC, conical, 6x1.5, 10.6mm²)
TKR6064 - Shock Pistons (CNC, conical, 6x1.6, 12.1mm²)
TKR6065 - Shock Piston Blanks (CNC, conical, 16 dimples, 16mm)
TKR6080 - Shock Spring Set (rear, 1.6 x 10.5T, 90mm, pink, 3.96 lb/in)
TKR6082 - Shock Spring Set (rear, 1.6 x 9.5T, 90mm, yellow, 4.48 lb/in)
TKR6083 - Shock Spring Set (rear, 1.6 x 9.0T, 90mm, orange, 4.80 lb/in)
TKR6090 - Shock Spring Set (front, 1.6 x 9.0T, 80mm, pink, 4.80 lb/in)
TKR6092 - Shock Spring Set (front, 1.6 x 8.0T, 80mm, yellow, 5.60 lb/in)
TKR6093 - Shock Spring Set (front, 1.6 x 7.5T, 80mm, orange, 6.11 lb/in)
TKR6146 - Shock Cartridge Set (CNC, Delrin, EB/NB/ET/NT/SCT)
TKR6159 - Shock Pistons (CNC, tapered, 4x1.8mm)
TKR6160 - Shock Piston Blanks (CNC, tapered, 16 dimples)

Name: Box Stock Date: _____ Event: _____

Track: Indoor Outdoor Size: Small Medium Large Traction: Low Med High

Surface: Smooth Bumpy Rutted Type: Loose/Loamy Hard Pack Blue Groove Clay

Bumpsteer/Ackerman/Servo Saver/Steering Stop: _____ Condition: Dusty Dry Wet Muddy

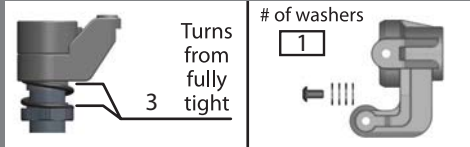
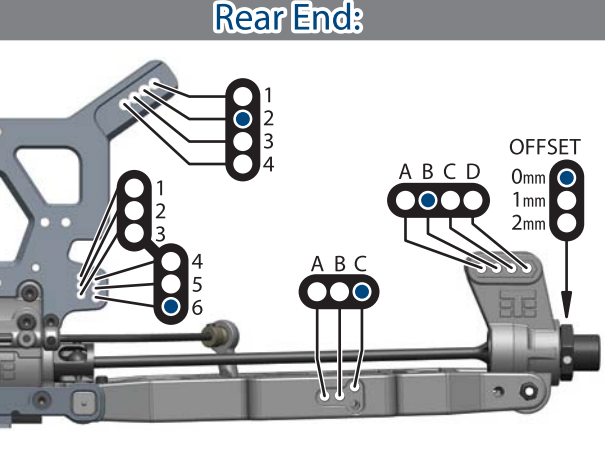
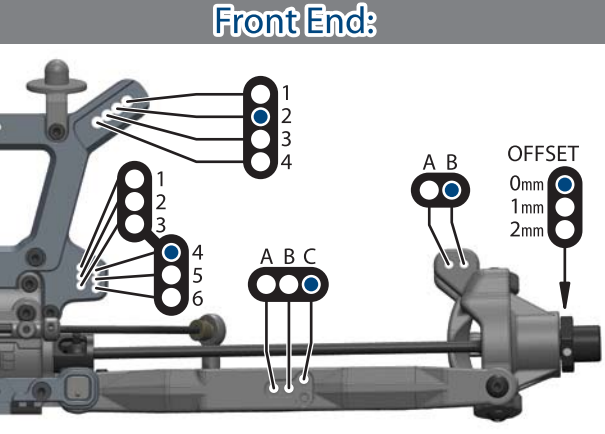
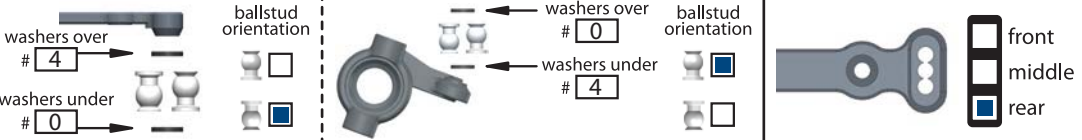

	FRONT	REAR
RIDE HEIGHT	37	40
CAMBER	-2	-2
CASTER	15 deg	
SWEEP	0 deg	
KICK UP	8.5 deg	
ANTI-SQUAT		2 deg
TOE (in/out)	.5 deg out	3 deg in
SWAY BAR	2.5	2.6
SHOCK LENGTH (DROOP)	122	136

Body/Wing:

BODY MAKE	Tekno
WING MAKE	Tekno

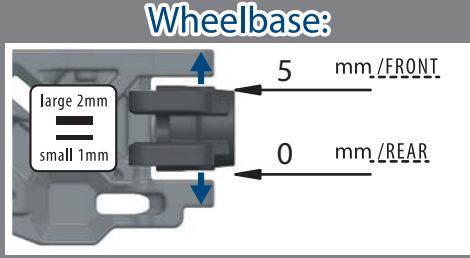
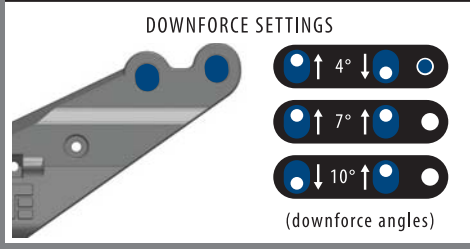
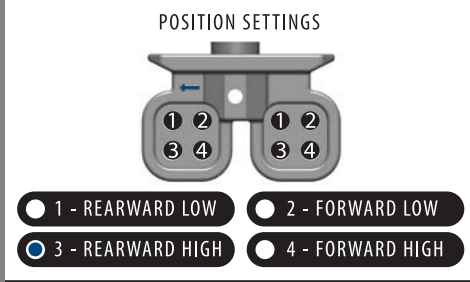

Shocks:

	FRONT	REAR
OIL	650	600
BRAND	Tekno	Tekno
PISTON	8x1.3 cone up	8x1.3 cone up
SPRING	green	green
REBOUND	0 %	0 %
STD/EMUL/VENT	STD	STD

NOTES:

Tires / Wheels:

	FRONT	REAR
BRAND/TREAD		
COMPOUND		
INSERT		
WHEEL		

NOTES:

Differential Oil:

FRONT	CENTER	REAR
10k	10k	5k

Equipment:

ENGINE/PIPE:	/
PLUG:	
FUEL:	
RX BATT:	
SERVOS:	(steering) 300oz min / (throttle/brake) 300oz min

Drivetrain:

CLUTCH/SPUR:	13 / 46 (teeth)
CLUTCH SHOES:	aluminum
CLUTCH SPRINGS:	2x red / 2x gold
BRAKE BIAS:	(front) 60 % / (rear) 40 %

Chassis Braces:

Center Left Rear Right Rear

(front brace is always recommended)

Notes:



Tekno RC
10755 Scripps Poway Pkwy #598
San Diego CA 92131
USA

www.teknorc.com

