

Name: \_\_\_\_\_ Date: \_\_\_\_\_ Event: \_\_\_\_\_

Track: Indoor  Outdoor  Size: Small  Medium  Large  Traction: Low  Med  High

Surface: Smooth  Bumpy  Rutted  Type: Loose/Loamy  Hard Pack  Blue Groove  Clay

Bumpsteer/Ackerman/Servo Saver/Steering Stop: \_\_\_\_\_ Condition: Dusty  Dry  Wet  Muddy

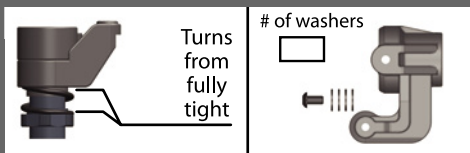
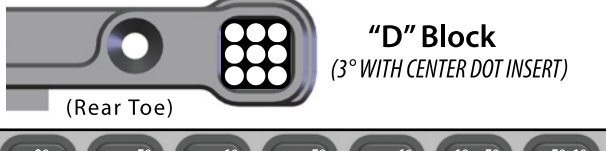
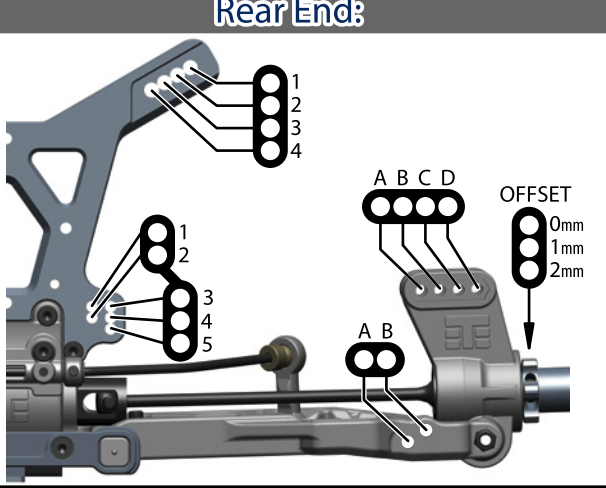
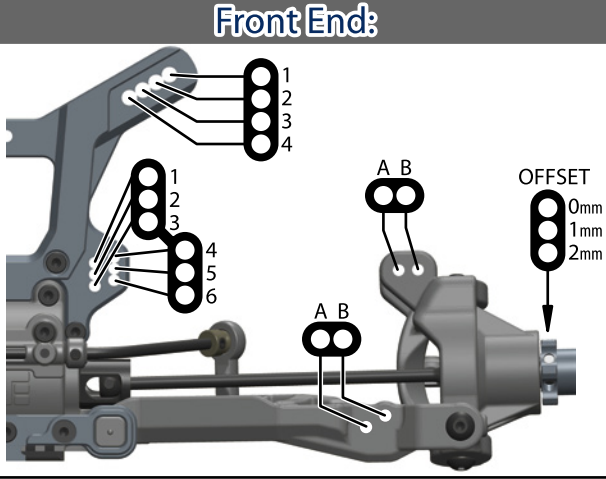
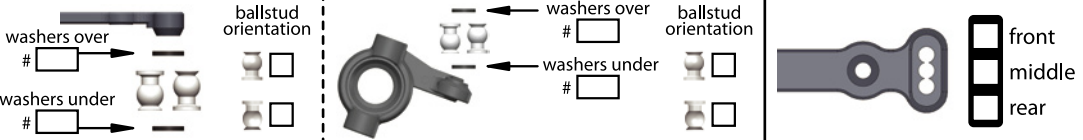

### Suspension:

|                      | FRONT | REAR |
|----------------------|-------|------|
| RIDE HEIGHT          |       |      |
| CAMBER               |       |      |
| CASTER               |       |      |
| SWEEP                |       |      |
| KICK UP              |       |      |
| ANTI-SQUAT           |       |      |
| TOE (in/out)         |       |      |
| SWAY BAR             |       |      |
| SHOCK LENGTH (DROOP) |       |      |

### Body/Wing:

|           |  |
|-----------|--|
| BODY MAKE |  |
| WING MAKE |  |

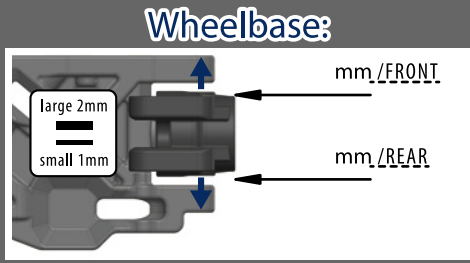
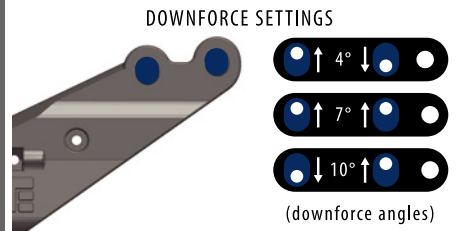
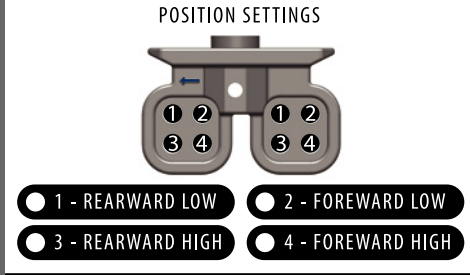

### Shocks:

|               | FRONT | REAR |
|---------------|-------|------|
| OIL           |       |      |
| BRAND         |       |      |
| PISTON        |       |      |
| SPRING        |       |      |
| REBOUND       | %     | %    |
| STD/EMUL/VENT |       |      |
| NOTES:        |       |      |

### Tires/Wheels:

|             | FRONT | REAR |
|-------------|-------|------|
| BRAND/TREAD |       |      |
| COMPOUND    |       |      |
| INSERT      |       |      |
| WHEEL       |       |      |
| NOTES:      |       |      |

### Differential Oil:

|  | FRONT | CENTER | REAR |
|--|-------|--------|------|
|  |       |        |      |

### Equipment:

|              |                               |  |
|--------------|-------------------------------|--|
| ENGINE/PIPE: | /                             |  |
| PLUG:        |                               |  |
| FUEL:        |                               |  |
| RX BATT:     |                               |  |
| SERVOS:      | (steering) / (throttle/brake) |  |

### Drivetrain:

|                 |                      |  |
|-----------------|----------------------|--|
| CLUTCH/SPUR:    | / (teeth)            |  |
| CLUTCH SHOES:   |                      |  |
| CLUTCH SPRINGS: |                      |  |
| BRAKE BIAS:     | (front) % / (rear) % |  |

### Chassis Braces:

Center  Left Rear  Right Rear

(front brace is always recommended)

Notes: