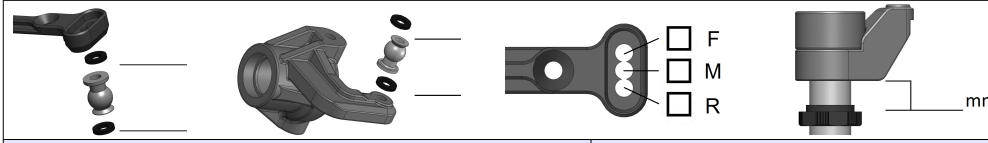

## SETUP SHEET

Name:	Date:	Event:
Track Conditions:	Outdoor    Open    Loose/Loamy    Dusty    High Bite	Low Bite    Rough
Indoor    Tight    Smooth    Hard Packed    Wet    Dry    Med Bite		Blue Groove

### BUMPSTEER/ACKERMANN/SERVO SAVER SHOCKS

 <div style="display: flex; justify-content: space-around; margin-top: 10px;"> <div style="text-align: center;"> <input type="checkbox"/> F  <input type="checkbox"/> M  <input type="checkbox"/> R         </div> <div style="text-align: center;"> <input type="checkbox"/> mm         </div> </div>	<table border="1" style="width: 100%; border-collapse: collapse;"> <tr> <th></th> <th>Front</th> <th>Rear</th> </tr> <tr> <td>Piston</td> <td></td> <td></td> </tr> <tr> <td>Oil</td> <td></td> <td></td> </tr> <tr> <td>Bladder</td> <td></td> <td></td> </tr> <tr> <td>Spring</td> <td></td> <td></td> </tr> <tr> <td>Length/ Droop</td> <td></td> <td></td> </tr> </table>		Front	Rear	Piston			Oil			Bladder			Spring			Length/ Droop		
	Front	Rear																	
Piston																			
Oil																			
Bladder																			
Spring																			
Length/ Droop																			

### FRONT SUSPENSION

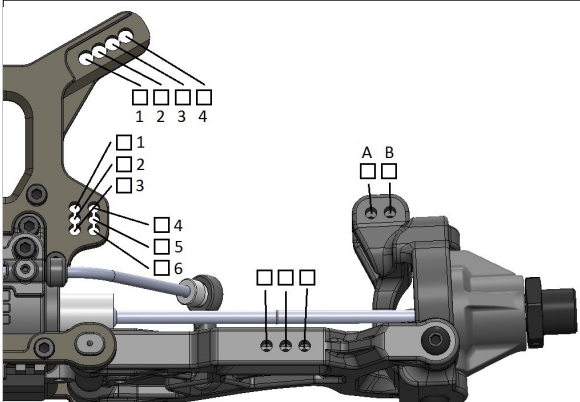
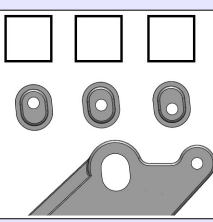
 <div style="display: flex; justify-content: space-around; margin-top: 10px;"> <div style="text-align: center;"> <input type="checkbox"/> 12    <input type="checkbox"/> 11    <input type="checkbox"/> 10              FR INNER           </div> <div style="text-align: center;"> <input type="checkbox"/> 1FRWD  <input type="checkbox"/> 0  <input type="checkbox"/> 1BACK              FR OUTER           </div> </div>	<table border="1" style="width: 100%; border-collapse: collapse;"> <tr> <th></th> <th>Front</th> <th>Rear</th> </tr> <tr> <td>Ride Height</td> <td></td> <td></td> </tr> <tr> <td>Camber</td> <td></td> <td></td> </tr> <tr> <td>Toe</td> <td></td> <td></td> </tr> <tr> <td>Sway Bar</td> <td></td> <td></td> </tr> </table> <h4 style="margin-top: 10px;">WING</h4> <p>Brand: <input type="checkbox"/> <input type="checkbox"/> <input type="checkbox"/></p> <p>Type: <input type="checkbox"/> <input type="checkbox"/> <input type="checkbox"/></p> 		Front	Rear	Ride Height			Camber			Toe			Sway Bar		
	Front	Rear														
Ride Height																
Camber																
Toe																
Sway Bar																

### REAR BRACES

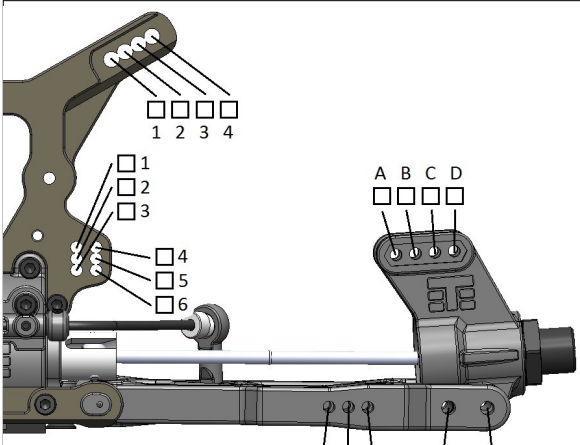
 <div style="display: flex; justify-content: space-around; margin-top: 10px;"> <div style="text-align: center;"> <input type="checkbox"/> 1    <input type="checkbox"/> 2    <input type="checkbox"/> 3              R INNER           </div> <div style="text-align: center;"> <input type="checkbox"/> 1.5  <input type="checkbox"/> 2.5  <input type="checkbox"/> 3.5              R OUTER           </div> </div>	<p>Notes:</p> <p><input type="checkbox"/> Front    <input type="checkbox"/> Middle    <input type="checkbox"/> Rear        (Front is always recommended)</p>
---	--

### WHEELBASE DIFFS

	<table border="1" style="width: 100%; border-collapse: collapse;"> <tr> <th></th> <th>Front</th> <th>Center</th> <th>Rear</th> </tr> <tr> <td></td> <td></td> <td></td> <td></td> </tr> </table>		Front	Center	Rear				
	Front	Center	Rear						

### DRIVETRAIN

Gear Ratio: _____ / _____	Spur: <input type="checkbox"/> Metal <input type="checkbox"/> Plastic
<input type="checkbox"/> Pinion <input type="checkbox"/> Long Shank <input type="checkbox"/> Traktion <input type="checkbox"/> Clutch	Shoes: Springs:
<input type="checkbox"/> Mech. Brake <input type="checkbox"/> Motor Brake	Radio Notes:

### NOTES: