

Name: _____ Date: _____ Event/Track: _____

Track Conditions: Outdoor Indoor Wet Dry High Bite Low Bite Rough
 Smooth Hard Packed Loose/Loamy Blue Groove

Bumpsteer/Ackerman/Servo Saver/Steering Stop:

washers
 over
 under
 ballstud

washers
 over
 under
 ballstud

front
 middle
 rear

Front End:

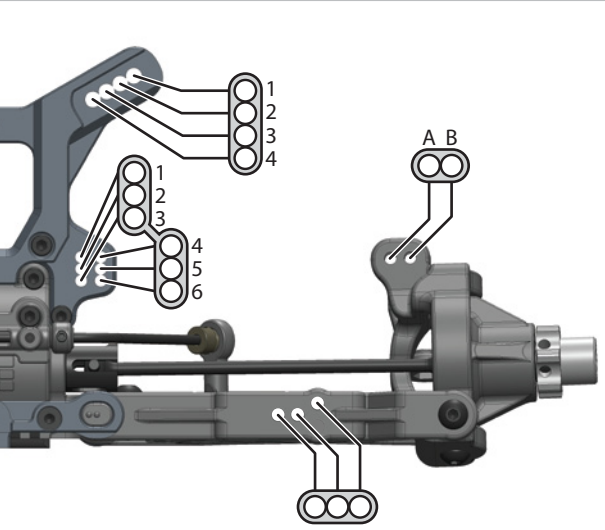

Front Outer (Sweep)

1.0F 0.5F 0.0 0.5R 1.0R

Front Inner (Kick Up)

10.0° 10.5° 11.0° 11.5° 12.0°

of turns from fully tightened

washers

Suspension:

	FRONT	REAR
RIDE HEIGHT:		
TOE (in/out):		
CAMBER:		
CASTER:		Deg°
SHOCK LENGTH (DROOP):		
SWAY BAR:		

NOTES:

Body/Wing:

BODY:	
WING:	

Rear End:

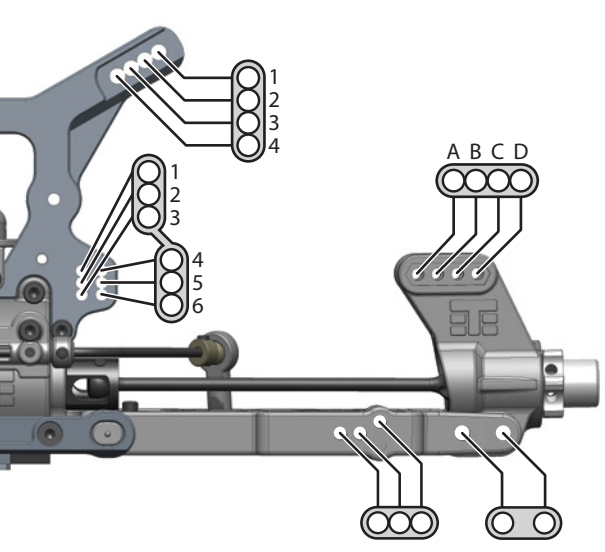

Rear Outer (Toe In)

2.5° 3.0° 3.5° 4.0° 4.5°

Rear Inner (Anti-Squat)

3.0° 2.5° 2.0° 1.5° 1.0°

(DOWNFORCE POSITION)

Wheelbase:

mm /FRONT

mm /REAR

large 2mm
 small 1mm

Notes:

Shocks:

	FRONT	REAR
STD/EMUL/VENT:		
PISTON:		
OIL:		
BLADDER:		
REBOUND:	%	%
SPRING:		

NOTES:

Tires / Wheels:

	FRONT	REAR
BRAND:		
TREAD:		
COMPOUND:		
INSERT:		
WHEEL:		

NOTES:

Differential Oil:

	FRONT	CENTER	REAR

NOTES:

Equipment:

BATTERY:	
ESC:	
MOTOR:	
RADIO:	
SERVO(s):	

NOTES:

Drivetrain:

PINION/BELL:			(teeth)
SPUR GEAR:	Metal <input type="checkbox"/>	Plastic <input type="checkbox"/>	
BRAKES:	Mech <input type="checkbox"/>	Motor <input type="checkbox"/>	
TRAKTION DRIVE:	Y/N	/	Springs

NOTES:
