

Setup Sheet for Team C TM2

Arm0 at PetitRC.com

Driver David Poulter

Track / City Eden Park Raceway, London

Event BRCA National Rnd 3 Date 25. / 05. / 2013

Conditions

- Smooth Bumpy Low traction Med traction High traction
 Sandy Soft dirt Grass Hard soil Clay Wet Dry Dusty Astro, Tarmac

Front Suspension Shock Mounting & Camber link

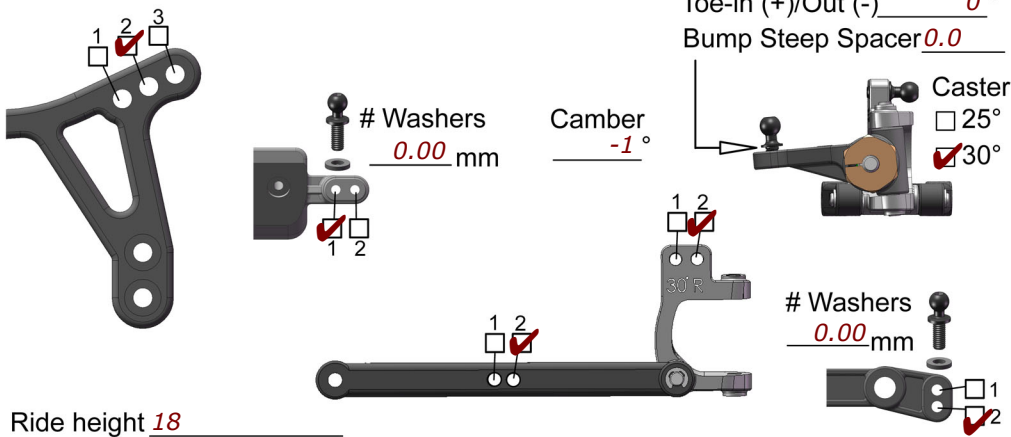

Front Shocks

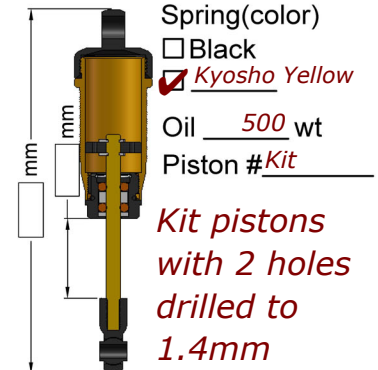

Rear Suspension Shock Mounting & Camber link

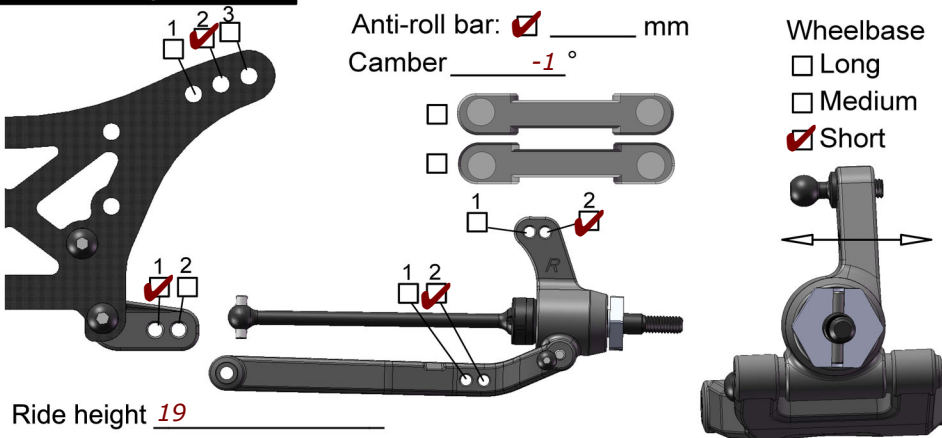

Rear Shocks

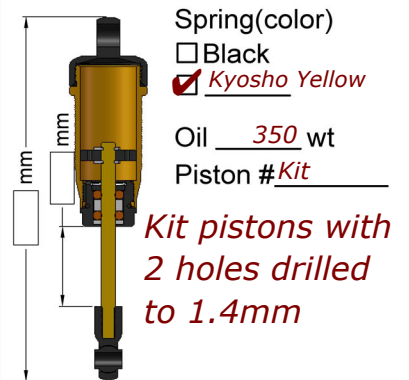

Front Tires & Wheels

Front Tires Schumacher Cut Stagger - Yellow
 Inserts None Wheels Kyosho

Rear Tires & Wheels

Rear Tires Schumacher Minispike - Yellow - R=10
 Inserts Mr O Foams - Blue Wheels Kyosho

Batteries

Servo Team Orion VDS2HV 1605
 Esc Team Orion R10
 Batteries Team Orion Shorty

Motor

Motor Team Orion VST2 6.5T
 Pinion/Spur 23 / 85

Other

Wing LMR
 Wing Angle 4° 10°
Gurney Level = 3 strips removed

Comments

Notes _____

Alloy rear hubs on outer hole with 2mm under. The car was easy to drive all day even in the damp conditions at the start of the day. Had a clean run in round 4 and got 5th in round. Qualified B2 and after a strong final challenging for the lead, finished B2. All rounds even with errors were top 20.