

TM2 V2

SETUP SHEET for the TeamC TM2 V2

Driver _____

Track / City _____

Event _____ Date ____ / ____ / ____

Conditions

- | | | | | |
|--|---------------------------------|------------------------------------|---------------------------------------|---------------------------------------|
| <input type="checkbox"/> High traction | <input type="checkbox"/> Smooth | <input type="checkbox"/> Bumpy | <input type="checkbox"/> Low traction | <input type="checkbox"/> Med traction |
| <input type="checkbox"/> Clay | <input type="checkbox"/> Sandy | <input type="checkbox"/> Soft dirt | <input type="checkbox"/> Grass | <input type="checkbox"/> Hard soil |
| | <input type="checkbox"/> Wet | <input type="checkbox"/> Dry | <input type="checkbox"/> Dusty | <input type="checkbox"/> _____ |

Front Suspension

Shock Mounting&Camber link

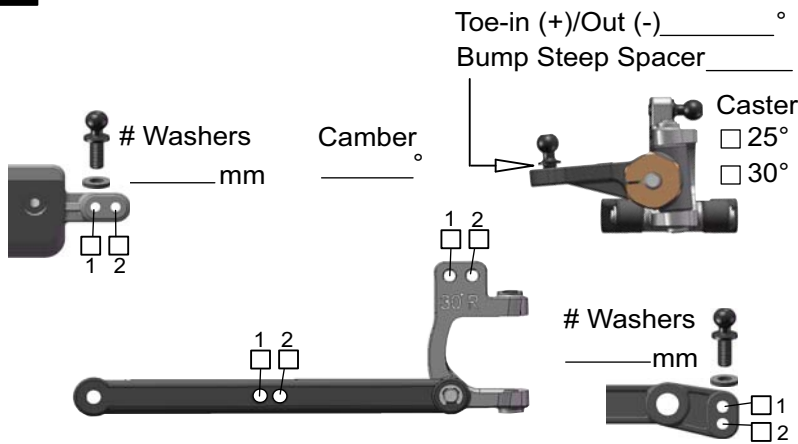
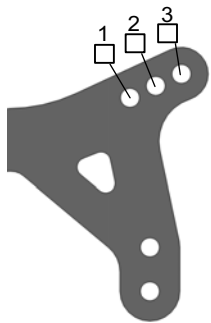

Ride height _____

Front Shocks

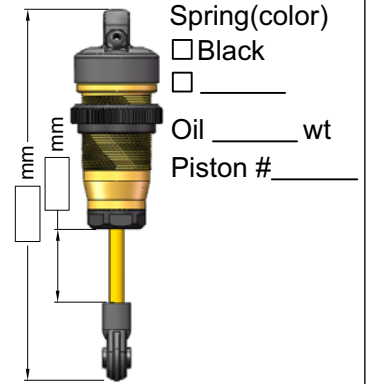

Rear Suspension

Shock Mounting&Camber link

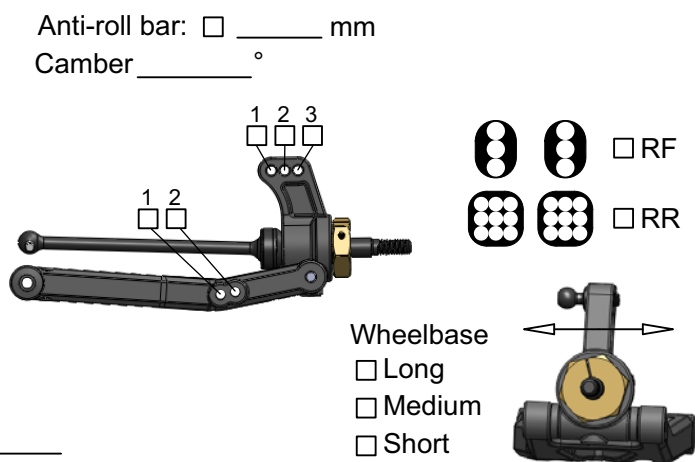
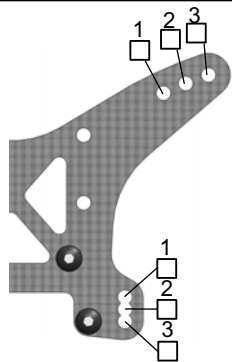

Ride height _____

Rear Shocks

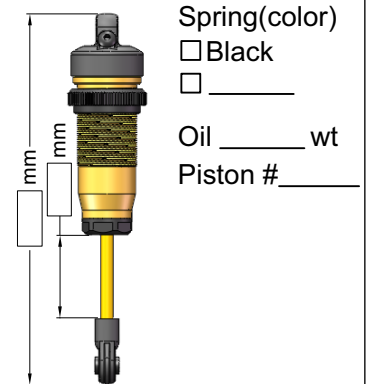

Diff

Brand _____
 Oil wt _____

Front Tires&Wheels

Front Tires _____
 Inserts _____ Wheels _____

Front Tires&Wheels

Front Tires _____
 Inserts _____ Wheels _____

Batteries

Servo _____
 Esc _____
 Batteries _____

Motor

Motor _____
 Pinion/Spur _____ / _____

Other

Wing _____
 Wing Angle 4° 10°

Arm0

Comments

